



# GLOBE

## GLOBE ARCHIMEDES COMPACT VANE MOTORS

### GALVANISED AND STAINLESS STEEL



## Your Global Force In Air Power



# GLOBE AIR POWER



## ATEX

## Ex II-2-GDc-T5

### ADVANTAGES

GLOBE-ARCHIMEDES compact vane air motors are motors with incorporated reduction units. They offer a unique form of drive with advantages including:

- Simple and inexpensive variable speed and torque control with a flow control valve and/or pressure regulator.
- Intrinsically safe for explosion proof environments. All GLOBE-ARCHIMEDES compact vane air motors are certified according to the European Explosion Directive ATEX II cat. 2 G&D T5.
- Indefinite stalling under load. Air motors will not overheat or burn out.
- Instantly reversible, operated with a simple control valve.
- Controllable over a wide speed range.
- Resistant to warm, dirty and damp conditions.
- Cool running caused by the expanding air.
- High reliability thanks to the low number of moving parts.
- Compact and light weight compared to equivalent electric motors.
- No shock start up which improves the life span of your equipment.

### WHY CHOOSE A GLOBE-ARCHIMEDES COMPACT VANE AIR MOTOR?

- Stainless steel models available for use in aggressive environments and foodstuffs industry.
- Mounting on the flange, the thread cut in the motors housing or on the motor housing itself.
- High torques and low speeds of rotation possible in application with limited mounting space.
- Small sized for hand held machinery.
- Motors can be supplied directly coupled to a wide range of gearboxes for higher torques.

### CONTENTS

### PAGE

ADVANTAGES/ WHY CHOOSE A GLOBE-ARCHIMEDES COMPACT VANE AIR MOTOR?	2
CHARACTERISTICS/ CONTROLLING AIR MOTORS	3
CONTROLLING AIR MOTORS	4
MODEL ORDERING CODE	4
DIMENSIONS/PERFORMANCES 2M	5
DIMENSIONS/PERFORMANCES 5M	6
DIMENSIONS/PERFORMANCE 9M	7

Photos on the front cover on courtesy of:

BPL, Haelen (NL) – Manipulator

Duits Engineering, Zutphen (NL) – Turning device

Gritco Equipment BV, Ridderkerk (NL) – Sand blasting equipment

Aerofilm Systems BV, Eindhoven (NL) – Lifting table

Hydrauvison, Schoondijke (NL) - Powerpack



GLOBE-ARCHIMEDES compact vane air motors in stainless steel

## CHARACTERISTICS OF VANE AIR MOTORS

The output power of a vane motor varies as a function of speed and torque. The relationship when the air supply is not externally regulated is shown in the graphs below.

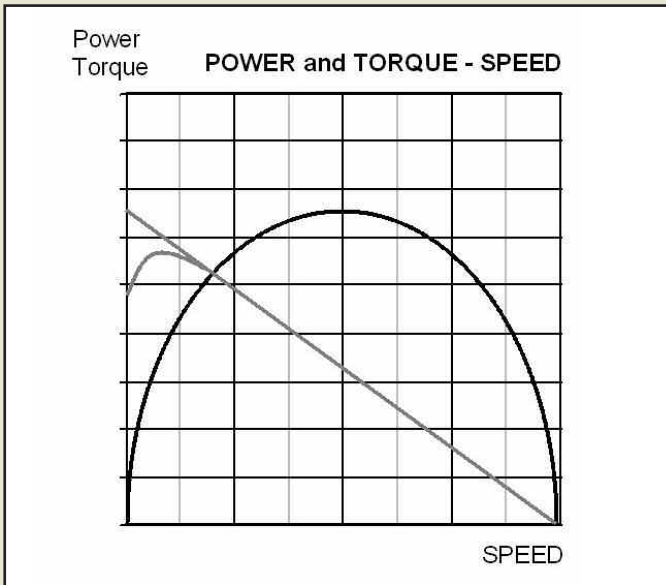

## Throttling methods

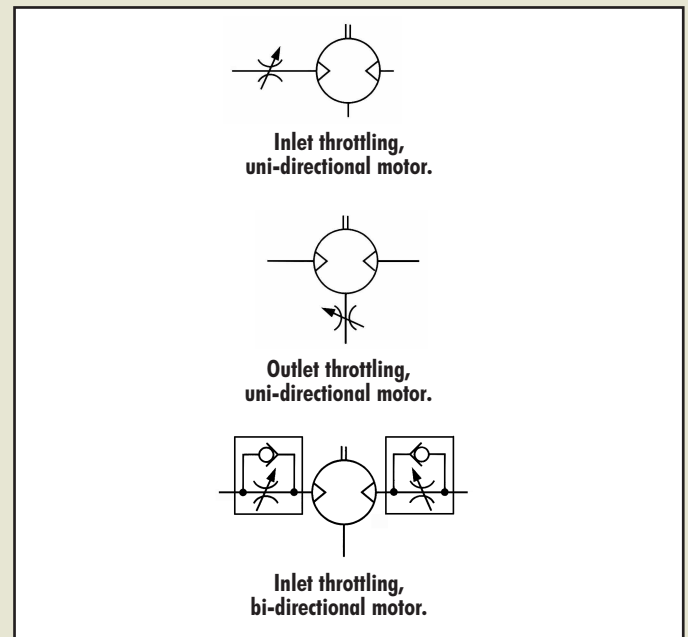

## CONTROLLING AIR MOTORS

### SPEED REGULATION

Controlling the speed and torque of an air motor is achieved by regulating the air supply; a relatively cheap and simple operation. Two methods are available, throttling and pressure regulation.

### THROTTLING

The air flow is controlled by placing a flow control valve at the inlet port or the outlet port of the air motor. Throttling will reduce the maximum speed of the motor but will not affect the starting performance; the air pressure is unaffected at low flow conditions i.e. starting. Note the difference in the graph between throttling on the inlet port and outlet port.

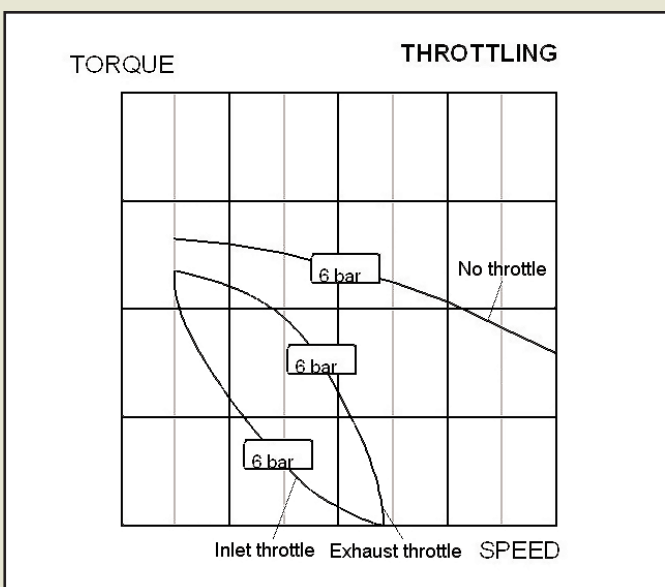

### Pressure regulator

The speed and power can also be reduced by installing a pressure regulator on the incoming air supply. The pressure regulator reduces the air pressure to the motor. A pressure regulator is always fitted on the inlet port. By using a pressure regulator the torque on the output shaft will be affected, starting torque is best controlled with this method.

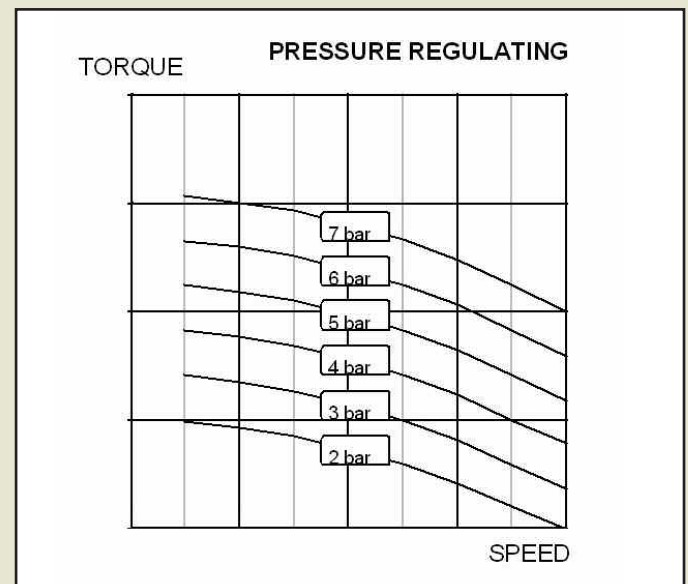

### Pressure regulating method

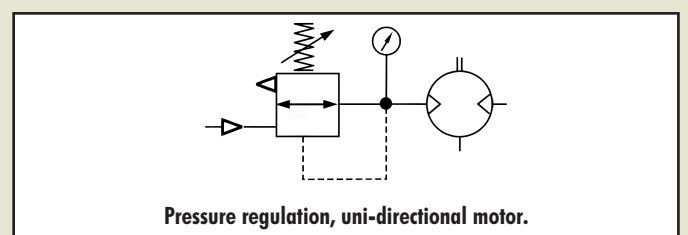

When both the speed and the torque are to be controlled the best configuration is to use a pressure regulator in the line to the motor and a flow control valve on the outlet port. This way every point in the torque-speed graph can be set accurately.

### Directions of rotation

The GLOBE-ARCHIMEDES compact vane air motors are available in uni-directional and in bi-directional models. When the uni-directional air motor is used, it is sufficient to use a 2/2 or a 3/2 valve. For the reversible motor you can use either a 5/3 or two 3/2 valve to gain directional control.

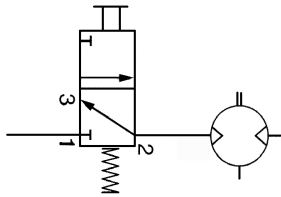

Uni-directional motor with 3/2 valve.

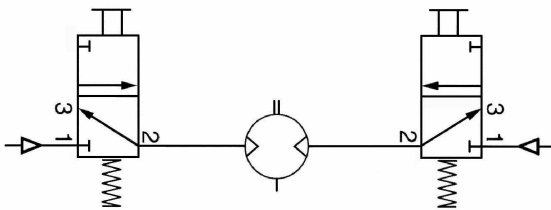

Bi-directional motor with two 3/2 valves.

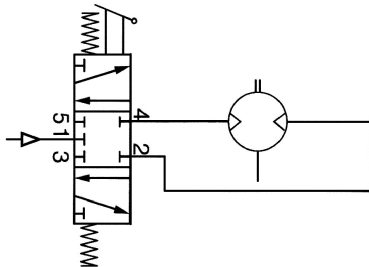

Bi-directional motor with 5/3 valve.

## Air supply

### Air quality

To insure optimal working conditions for the GLOBE-ARCHIMEDES compact vane air motors, the air supply must be dry, filtered and lubricated. A 5 micron filter is recommended. The air motors should be lubricated sufficiently.

### Air line restrictions

Air line restrictions on the inlet side of the motor will result in performance loss. Therefore it is important to make sure that the desired air pressure is available at the motor during operation. The pressure reading at the compressor or pressure regulator may be different than the pressure available at the motor.

Performance loss can also occur by an exhaust restriction generating back pressure on the outlet side of the motor. An insufficiently sized silencer, valve or coupling is usually the cause.

## MODEL ORDERING CODE

2M - X - X - X  
5M - X - X - X  
9M - X - X - X

X = Galvanised steel  
X = Stainless steel

R = reversible  
X = Non-reversible.  
Rotation CCW looked onto the shaft.

Minimum starting torque

### Ordering example

You order the 5M34R. We deliver the compact vane air motor type 5M with a minimum starting torque of 34 Nm, a galvanised steel housing, reversible.

# DIMENSIONS 2M

TYPE	a	b	c	l	l1	l2	M	d	d1	d2	d3
2M01	52	64	5	160	20	25	M4	40h9	10h6	36h9	6,5
2M02				160							
2M12				190							
2M02R				160							
2M10R				190							

All dimensions in mm

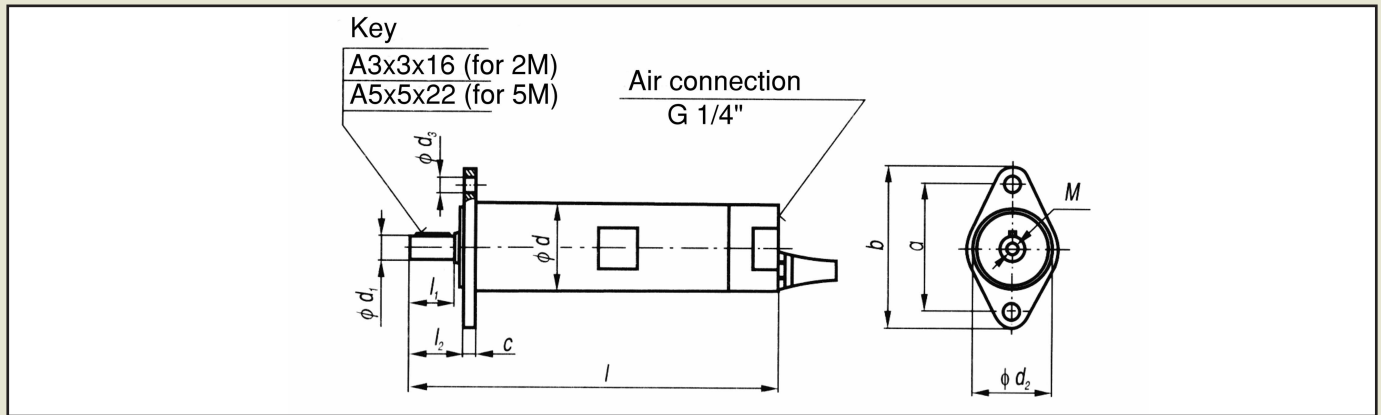

# PERFORMANCES 2M

TYPE	POWER (kW)	MAX RPM	MIN STARTING TORQUE (Nm)	ROTATION	AIR CONSUMPTION (M <sup>3</sup> /min)	GEAR RATIO	WEIGHT (Kg)
2M01	0,27	19.000	0,4	COUNTER CLOCKWISE	0,5	1	0,9
2M02		3700	2			5	0,9
2M12		710	12			25	1,1
2M02R	0,24	3100	2	REVERSIBLE	0,6	5	0,9
2M10R		600	10			25	1,1

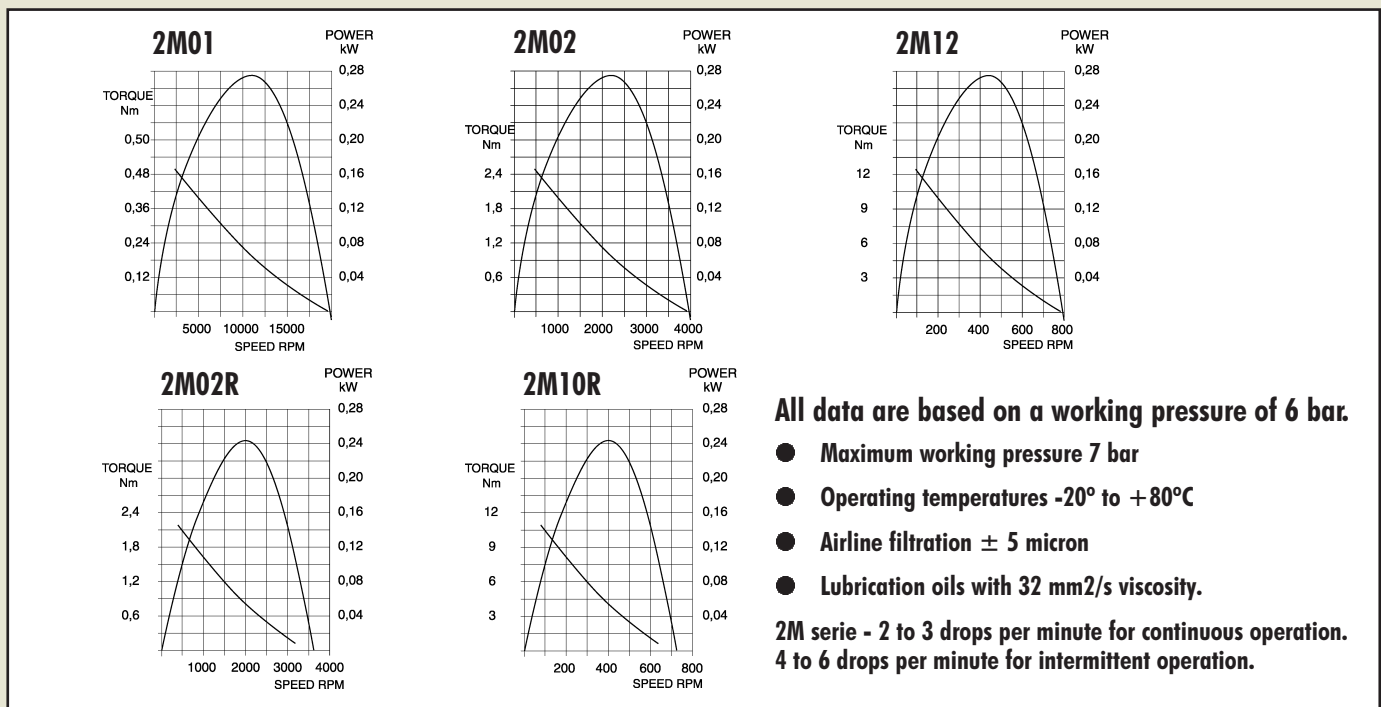

All data are based on a working pressure of 6 bar.

- Maximum working pressure 7 bar
- Operating temperatures -20° to +80°C
- Airline filtration ± 5 micron
- Lubrication oils with 32 mm<sup>2</sup>/s viscosity.

2M serie - 2 to 3 drops per minute for continuous operation.  
 4 to 6 drops per minute for intermittent operation.

Note: exhaust is through common exhaust port and opposite rotation inlet port. Blocking or restricting these ports will reduce the performance of the motor.

# DIMENSIONS 5M

TYPE	a	b	c	l	l1	l2	M	d	d1	d2	d3
5M01	75	95	6	185	30	35	M6	55h9	14h6	52h9	11
5M06				185							
5M43				230							
5M05R				185							
5M34R				230							

All dimensions in mm

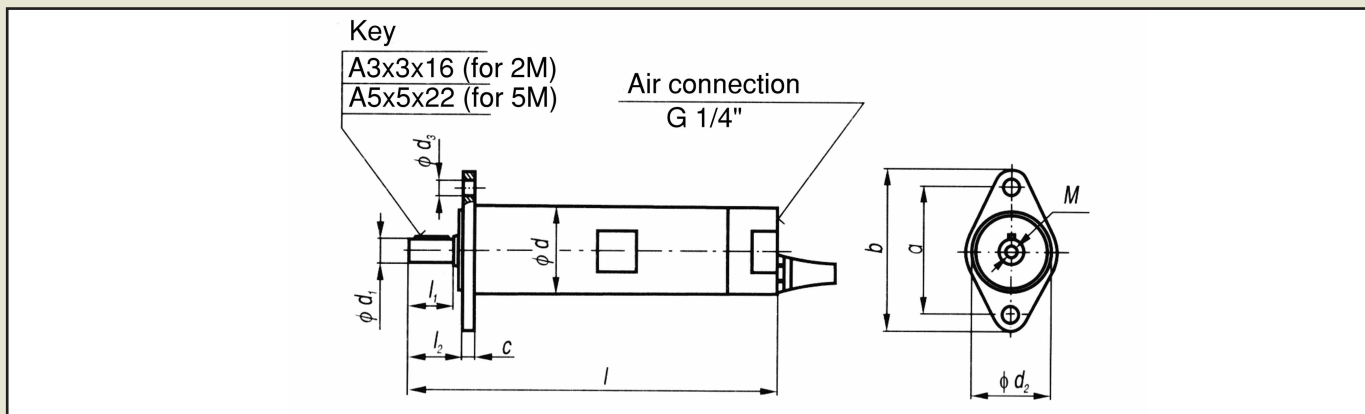

# PERFORMANCES 5M

TYPE	POWER (kW)	MAX RPM	MIN STARTING TORQUE (Nm)	ROTATION	AIR CONSUMPTION (M <sup>3</sup> /min)	GEAR RATIO	WEIGHT (Kg)
5M01	0,67	14.000	1,5	COUNTER CLOCKWISE	0,8	1	2,0
5M06		3250	6			5	2,0
5M43		450	43			36	2,4
5M05R	0,61	3000	5	REVERSIBLE	0,83	5	2,0
5M34R		420	34			36	2,4

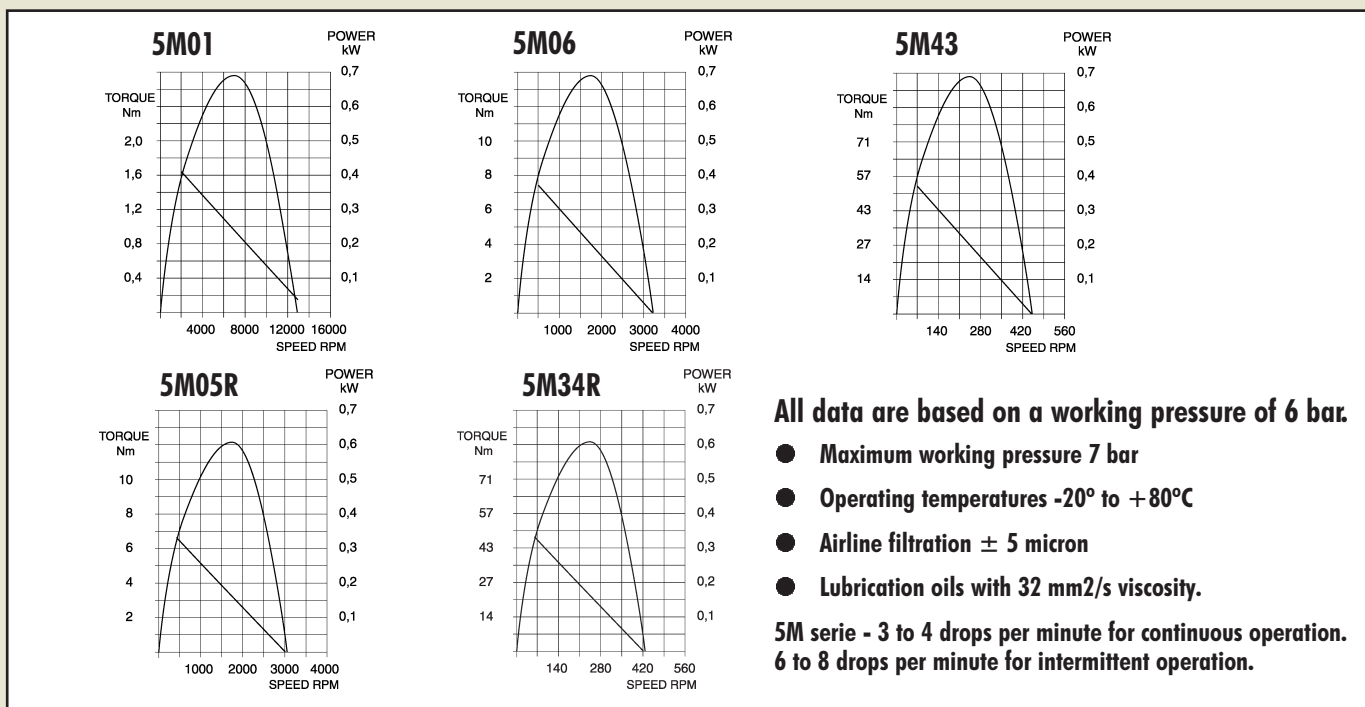

All data are based on a working pressure of 6 bar.

- Maximum working pressure 7 bar
- Operating temperatures -20° to +80°C
- Airline filtration ± 5 micron
- Lubrication oils with 32 mm<sup>2</sup>/s viscosity.

5M serie - 3 to 4 drops per minute for continuous operation.  
6 to 8 drops per minute for intermittent operation.

Note: exhaust is through common exhaust port and opposite rotation inlet port. Blocking or restricting these ports will reduce the performance of the motor.

# DIMENSIONS 9M

TYPE	a	b	c	l	l1	l2	l3	M	d	d1	d2	d3	d4
9M70R	75	95	6	270	30	35	110	M4	55h9	16h9	52h9	11	62

All dimensions in mm

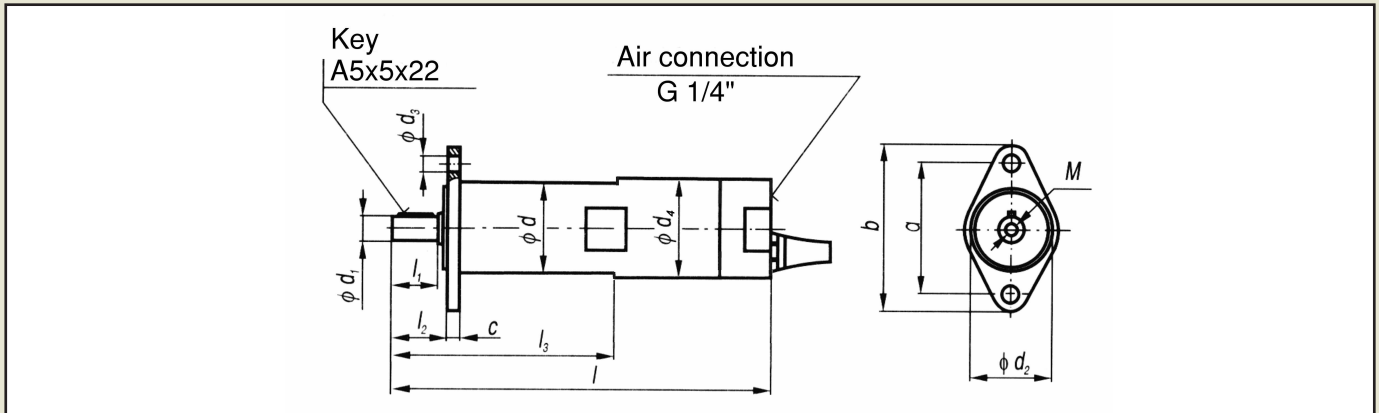

# PERFORMANCE 9M

TYPE	POWER (kW)	MAX RPM	MIN STARTING TORQUE (Nm)	ROTATION	AIR CONSUMPTION (M <sup>3</sup> /min)	GEAR RATIO	WEIGHT (Kg)
9M70R	1,0	440	70	REVERSIBLE	1,36	36	3,3

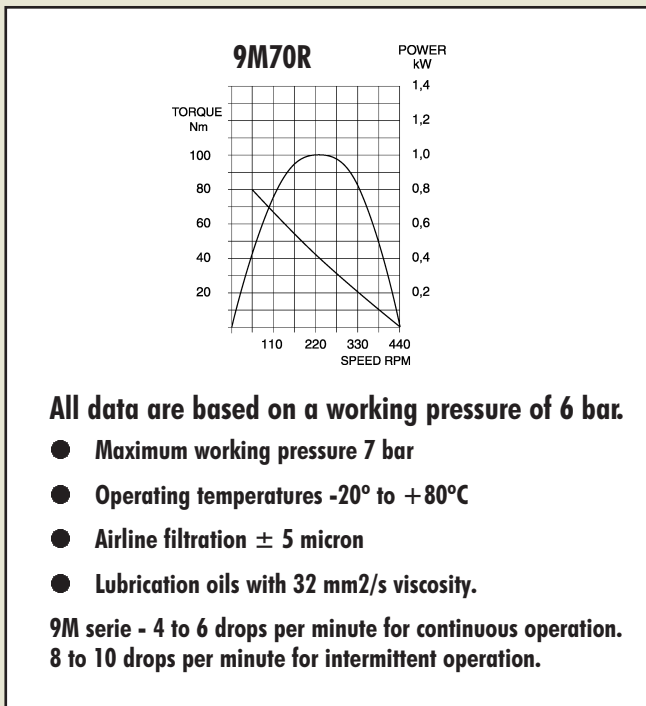

Note: exhaust is through common exhaust port and opposite rotation inlet port. Blocking or restricting these ports will reduce the performance of the motor.



# Globe Airmotors Program



## Vane Air Motor

Reversible, available in flange, foot, or face execution.  
Power from 0,44 to 9,5 kW.



## Compact Air Motor

Reversible, compact, available with a wide range of  
incorporated reduction units. Power from 180 to 1000 W.



## Planetary Geared Vane Air Motor

Reversible and a compact solution. Available with gear  
ratios from 3:1 to 1000:1. Power from 0,44 to 5,4 kW.



## Vane Air Motor with Gearbox

Available with planetary, coaxial, or worm gearboxes. Also  
possible with pneumatic brake.



## Compact Piston Air Motor

High torque at low speed of rotation, very low air  
consumption and low noise level.  
Power from 110 to 460 W.



## Radial Piston Air Motor

Available with proportional hand or remotely controlled  
valve, pneumatic brake and all types of gearboxes.  
Power from 0,8 to 23 kW.

DISTRIBUTOR



**GLOBE** AIRMOTORS B.V.

Eikenlaan 261e

NL-2404 BP Alphen a/d Rijn

Tel: (+31)-(0)172-426608

Fax: (+31)-(0)172-426607

Website: <http://www.globe-benelux.nl>

E-mail: [info@globe-benelux.nl](mailto:info@globe-benelux.nl)