

PRODUCT SPECIFICATION

August 2005

PNEUMATIC AND ELECTRIC ACTUATED INDUSTRIAL VALVES

SERIES: 3800 SIZES 1 to 8 INCHES

E-Ball Rotary Control Valves

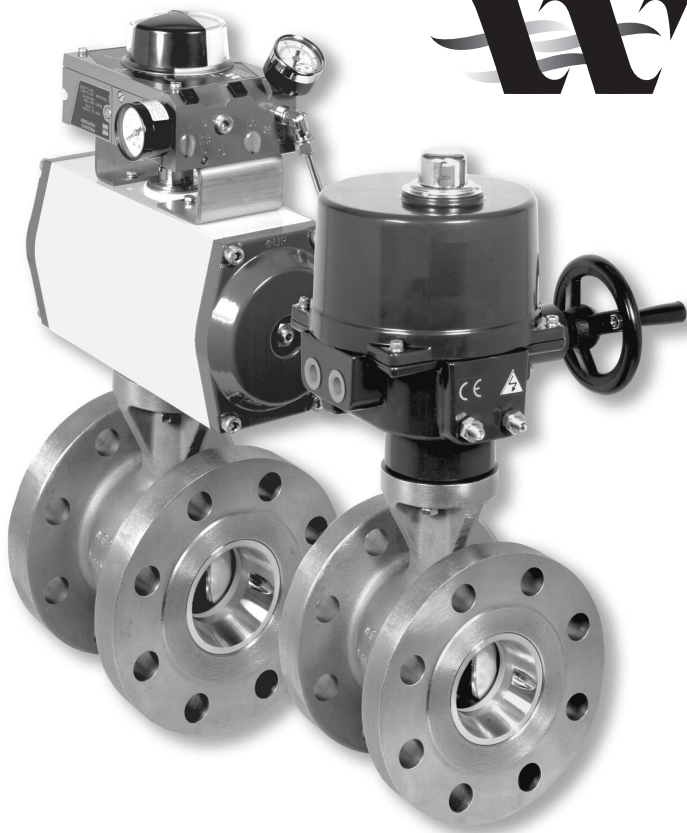

WARREN CONTROLS

High performance, reduced wear, eccentric plug rotary control valves. Available with superior erosion resistant TTZ ceramic trim. Bodies available custom cast in a vast array of specialized alloys to meet your requirements: Hastelloy, Zirconium, Titanium, Alloy 20, Kryptonite, CD4MCu....

Table of Contents

Features and Advantages	2
Internal Configurations Vs Performance	3
Materials of Construction	4
Performance Characteristics	5
<i>Body Pressure-Temperature Ratings</i>	5
<i>Flowing Differential Pressure Limits</i>	5
<i>Allowable Seat Leakage</i>	5
Sizing Reference and Load Sizing Calculations	6
Flow Coefficients (Cv) Versus Travel	7-8
Additional Coefficients	9
Flow Curve	9
Rated Torques	10-11
Actuator Torques	12-13
Actuators	14
Actuator Interface	15
Piping Orientation	16
Actuator Orientation and Flow Direction	17-18
Positioners and Accessories	19-20
Dimensions and Weights	21-22
Flange Sizes and Patterns	23
Factory Default Settings	24
Configurations	25-26

W SERIES: **3800** *E-Ball Rotary Valve*

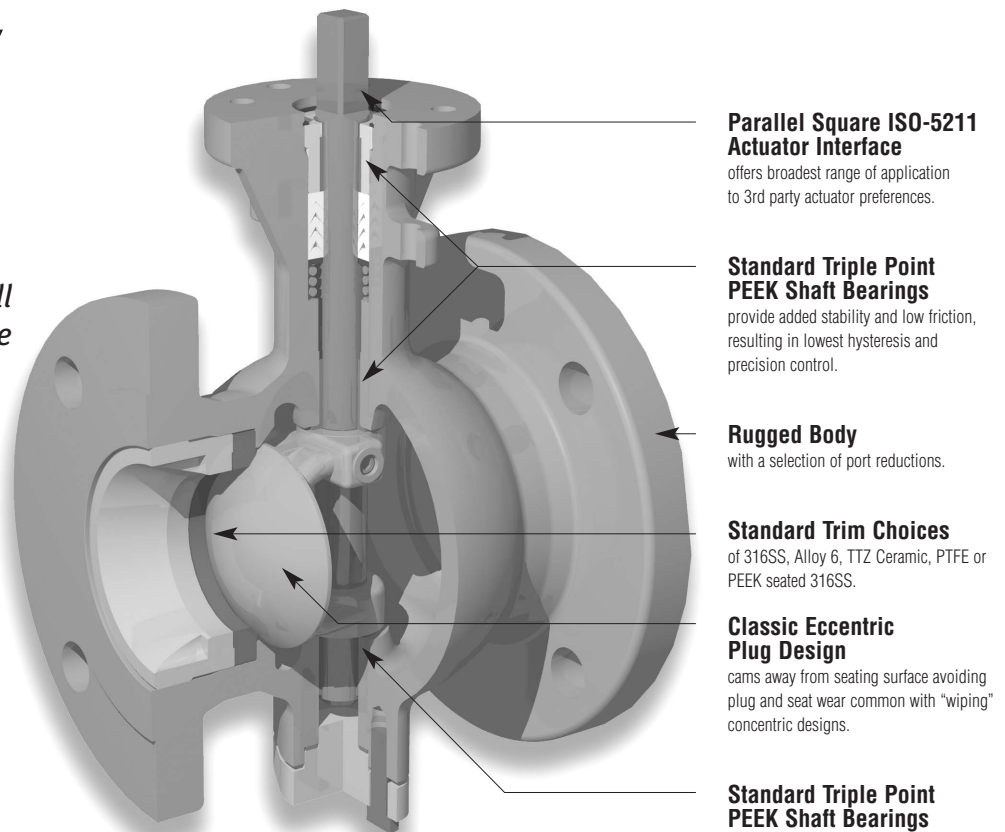

Description

The 3800 Series Rotary Globe Control Valve incorporates the time-tested and proven Segmented Ball–Eccentric Geometry design (E-Ball), combining exceptionally tight control and rangeability (100:1), with superior trim wear characteristics inherent with the eccentric design.

Available as completely automated valve assemblies with the highest quality actuators and accessories or as bare stem product ready for your automation needs, the 3800 Series comes in a wide variety of standard options for body/trim materials and construction builds, from Class IV to Class VI shut off.

The ever-popular TTZ Ceramic Trim is an off-the-shelf choice for erosive or corrosive fluids and a vast array of custom alloys can be selected for custom construction, engineered to your specific application needs.

The 3800 can flow in the forward direction, flow-to-open; or reverse direction, flow-to-close. The 3800 is available in a thru-shaft or split-shaft configuration. These features allow for maximum flexibility in matching benefits to your application.

Ruggedness & High Performance

Features	Advantages
Eccentric E-ball plug	Provides exceptional modulating control with 100:1 rangeability.
One-piece straight thru body	Compact package with streamlined flow passage yields high Cv's handling greater flow capacities.
Body materials	Standard body materials are WCB steel and CF8M stainless steel. Bodies available custom cast in other specialized alloys: Hastelloy B & C, Zirconium, Titanium, Alloy 20, CD4MCu...
Trim components	Durable rugged plug and seat construction shuts off tightly without deforming plug arms or employing thin ball seals.
Trim materials	TTZ ceramic and Alloy 6 trim promote long dependable service life in applications controlling erosive and hard to handle fluids. 316 stainless steel trim, PEEK & TFE soft seat trim available for non-erosive service.
Forward or reverse flow direction	Choice of forward flow (flow-to-open) or reverse flow (flow-to-close) directions maximizes flexibility in meeting application requirements.
Reduced ports	1, 2, & 3 sizes reduced trim available. Provides flexibility in matching valve size to flow requirements.
ISO 5211 parallel square shaft	Solid actuator interface. Provides zero backlash. Assures minimum dead band and hysteresis.
Thru- or split-shaft	Choice of one-piece thru-shaft or two-piece split-shaft maximizes flexibility in meeting application requirements.
Shaft, drive pin, plug connection	Eliminates backlash.
Oversized bearings and shafts	Ideal for high pressure drops.
Extension bonnet	Allows for wide range of temperature applications

Increased Serviceability & Reduced Maintenance

Features	Advantages
Integral valve body flanges	Promote secure valve installations and piping integrity. Easy installation. Eliminate exposed line flange bolting. Shorten alignment and installation time. Many different classes of pipe flanges.
Eccentric plug rotation	Minimizes contact with seat ring until plug is fully seated reducing friction and wear.
Segmented ball design	In control range reduces risk of cavitation as compared to a full bore ball valve.
90 degree shaft rotation	Removes valve plug from flow stream reducing plug wear.
Rotary shaft with TFE v-ring or graphite packing	Reduces packing wear. Minimizes potential for packing leaks

Established Features & Quality

Features	Advantages
Rotary Control Valve	Rotary design is rugged and compact providing higher Cv's than linear globe designs. Matched with rotary actuators to produce heavy duty automatic throttling control valve which dependably controls both clean and dirty fluids in many process industries.
Electric actuators	Powerful, low profile, high torque actuators with reversible 4-20mA or 2-10Vdc input and feedback. Features integral hand wheel for manual override and large highly visible valve position indicator.
Pneumatic rack & pinion actuators	Powerful, low profile, high torque actuators with large, highly visible, valve position indicator. Supply pressures to 120 psig. Declutchable gear operator available for manual override. Combine actuators with pneumatic accessories to allow for wide variety of control actions.
Wide variety of accessories	Pneumatic and electro-pneumatic positioners for intrinsically safe, explosion proof, or fail freeze operation. Digital positioners and communications, intelligent keypad, Hart, and foundation fieldbus inputs available. 3-way and 4-way solenoids also available.

Internal Configurations Vs Performance

Internal Configurations						Performance			
Trim Material/Code	Shaft Design/Code	Shaft Material/Code	Bearing & Seals/Code ¹	Packing/Code	Flow Direction	ANSI Leakage ²	Fluid	Max Temp ³	
316 Stainless Steel S	Thru Direct C or Split Direct E	17-4 Hard S	PEEK S	Teflon V-ring T	Flow to Open Flow to Close	Class IV	Non-Corrosive Non-Erosive	450°F	
316 Stainless Steel S	Thru Direct C or Split Direct E	17-4 Hard S	PEEK w/Flouraz 797 Seal T	Teflon V-ring T	Flow to Open Flow to Close	Class IV	Non-Corrosive Non-Erosive	450°F	
316 Stainless Steel S	Thru Direct C or Split Direct E	17-4 Hard S	Alloy 6B 6	Teflon V-ring T	Flow to Open Flow to Close	Class IV	Non-Corrosive Non-Erosive	450°F	
316 Stainless Steel S	Thru Direct C or Split Indirect E	17-4 Hard S	Alloy 6B w/Flouraz 797 Seal Y	Teflon V-ring T	Flow to Open Flow to Close	Class IV	Non-Corrosive Non-Erosive	450°F	
316 Stainless Steel S	Thru Indirect D or Split Indirect F	17-4 Hard S	Alloy 6B w/Flouraz 797 Seal Y	Graphite G	Flow to Open Flow to Close	Class IV	Non-Corrosive Non-Erosive	500°F	
316 Stainless Steel S	Thru Indirect D or Split Indirect F	17-4 Hard S	Alloy 6B 6	Graphite G	Flow to Open Flow to Close	Class IV	Non-Corrosive Non-Erosive	800°F	
TTZ Ceramic Z	Thru Direct C or Split Direct E	17-4 Hard S	PEEK S	Teflon V-ring T	Flow to Open Flow to Close	Class IV	Non-Erosive	450°F	
TTZ Ceramic Z	Thru Direct C or Split Direct E	17-4 Hard S	PEEK w/Flouraz 797 Seal T	Teflon V-ring T	Flow to Open Flow to Close	Class IV Class IV+	Non-Erosive Erosive	450°F 450°F	
TTZ Ceramic Z	Thru Direct C or Split Direct E	17-4 Hard S	Alloy 6B 6	Teflon V-ring T	Flow to Open Flow to Close	Class IV Class IV+	Non-Erosive Erosive	450°F 450°F	
TTZ Ceramic Z	Thru Direct C or Split Direct E	Inconel 718 I	Alloy 6B 6	Teflon V-ring T	Flow to Open Flow to Close	Class IV Class IV+	Corrosive & Non-Erosive Corrosive & Erosive	450°F 450°F	
TTZ Ceramic Z	Thru Direct C or Split Direct E	17-4 Hard S	Alloy 6B w/Flouraz 797 Seal Y	Teflon V-ring T	Flow to Open Flow to Close	Class IV Class IV+	Non-Erosive Erosive	450°F 450°F	
TTZ Ceramic Z	Thru Direct C or Split Direct E	Inconel 718 I	Alloy 6B w/Flouraz 797 Seal Y	Teflon V-ring T	Flow to Open Flow to Close	Class IV Class IV+	Corrosive & Non-Erosive Corrosive & Erosive	450°F 450°F	
TTZ Ceramic Z	Thru Indirect D or Split Indirect F	17-4 Hard S	Alloy 6B w/Flouraz 797 Seal Y	Graphite G	Flow to Open Flow to Close	Class IV Class IV+	Non-Erosive Erosive	500°F 500°F	
TTZ Ceramic Z	Thru Indirect D or Split Indirect F	Inconel 718 I	Alloy 6B w/Flouraz 797 Seal Y	Graphite G	Flow to Open Flow to Close	Class IV Class IV+	Corrosive & Non-Erosive Corrosive & Erosive	500°F 500°F	
TTZ Ceramic Z	Thru Indirect D or Split Indirect F	17-4 Hard S	Alloy 6B 6	Graphite G	Flow to Open Flow to Close	Class IV Class IV+	Non-Erosive Erosive	800°F 800°F	
TTZ Ceramic Z	Thru Indirect D or Split Indirect F	Inconel 718 I	Alloy 6B 6	Graphite G	Flow to Open Flow to Close	Class IV Class IV+	Corrosive & Non-Erosive Corrosive & Erosive	800°F 800°F	
TFE Soft Seats T	Thru Direct C or Split Direct E	17-4 Hard S	PEEK S	Teflon V-ring T	Flow to Open Flow to Close	Class VI	Non-Corrosive Non-Erosive	450°F	
TFE Soft Seats T	Thru Direct C or Split Direct E	17-4 Hard S	PEEK w/Flouraz 797 Seal T	Teflon V-ring T	Flow to Open Flow to Close	Class VI	Non-Corrosive Non-Erosive	450°F	
PEEK Soft Seats P	Thru Direct C or Split Direct E	17-4 Hard S	PEEK S	Teflon V-ring T	Flow to Open Flow to Close	Class VI	Non-Corrosive Non-Erosive	450°F	
PEEK Soft Seats P	Thru Direct C or Split Direct E	17-4 Hard S	PEEK w/Flouraz 797 Seal T	Teflon V-ring T	Flow to Open Flow to Close	Class VI	Non-Corrosive Non-Erosive	450°F	
Alloy 6 6	Thru Direct C or Split Direct E	17-4 Hard S	PEEK S	Teflon V-ring T	Flow to Open Flow to Close	Class IV	Non-Erosive	450°F	
Alloy 6 6	Thru Direct C or Split Direct E	17-4 Hard S	PEEK w/Flouraz 797 Seal T	Teflon V-ring T	Flow to Open Flow to Close	Class IV Class IV	Non-Erosive Erosive	450°F 450°F	
Alloy 6 6	Thru Direct C or Split Direct E	17-4 Hard S	Alloy 6B 6	Teflon V-ring T	Flow to Open Flow to Close	Class IV Class IV	Non-Erosive Erosive	450°F 450°F	
Alloy 6 6	Thru Direct C or Split Direct E	Inconel 718 I	Alloy 6B 6	Teflon V-ring T	Flow to Open Flow to Close	Class IV Class IV	Corrosive & Non-Erosive Corrosive & Erosive	450°F 450°F	
Alloy 6 6	Thru Direct C or Split Direct E	17-4 Hard S	Alloy 6B w/Flouraz 797 Seal Y	Teflon V-ring T	Flow to Open Flow to Close	Class IV Class IV	Non-Erosive Erosive	450°F 450°F	
Alloy 6 6	Thru Direct C or Split Direct E	Inconel 718 I	Alloy 6B w/Flouraz 797 Seal Y	Teflon V-ring T	Flow to Open Flow to Close	Class IV Class IV	Corrosive & Non-Erosive Corrosive & Erosive	450°F 450°F	
Alloy 6 6	Thru Indirect D or Split Indirect F	17-4 Hard S	Alloy 6B w/Flouraz 797 Seal Y	Graphite G	Flow to Open Flow to Close	Class IV Class IV	Non-Erosive Erosive	500°F 500°F	
Alloy 6 6	Thru Indirect D or Split Indirect F	Inconel 718 I	Alloy 6B w/Flouraz 797 Seal Y	Graphite G	Flow to Open Flow to Close	Class IV Class IV	Corrosive & Non-Erosive Corrosive & Erosive	500°F 500°F	
Alloy 6 6	Thru Indirect D or Split Indirect F	17-4 Hard S	Alloy 6B 6	Graphite G	Flow to Open Flow to Close	Class IV Class IV	Non-Erosive Erosive	800°F 800°F	
Alloy 6 6	Thru Indirect D or Split Indirect F	Inconel 718 I	Alloy 6B 6	Graphite G	Flow to Open Flow to Close	Class IV Class IV	Corrosive & Non-Erosive Corrosive & Erosive	800°F 800°F	

¹ Seal protects bearing and shaft from small particles.

² See "Allowable Seat Leakage" on page 5 for definitions of Class IV, IV+, & VI.

³ For Maximum Temperatures see also Valve Body Pressure-Temperature Ratings and Actuator Temperature Ratings.

Body Materials

Item	Part Nomenclature	Materials
Code: W WCB Body		
8	Valve Body	Steel A216 WCB
13	Gasket	Nonasbestos
14	Bottom Cover	Steel A216 WCB
15	Hex Head Capscrew	Alloy Steel GR B7
30	O-ring	Flouraz 797
31	Bottom Plug	STEEL
Code: F CF8M Body		
8	Valve Body	SST A351 CF8M
13	Gasket	Nonasbestos
14	Bottom Cover	SST A351 CF8M
15	Hex Head Capscrew	SST GR B8M Class 2
30	O-ring	Flouraz 797
31	Bottom Plug	316 SST

Trim Materials

Item	Part Nomenclature	Materials
Code: S 316 Stainless Steel Trim		
9	Fixed Adjustable Seat Ring	316 SST
10	Seat Retainer	316 SST
11	Plug	316 SST
27	Set Screw	316 SST
29	Socket Head Capscrew	316 SST
Code: Z TTZ Ceramic Trim		
9	Fixed Adjustable Seat Ring	TTZ Zirconia Ceramic
27	Set Screw	316 SST
29	Socket Head Capscrew	316 SST
32	Blank Plug	316 SST
33	Plug Face	TTZ Zirconia Ceramic
34	Retaining Screw	Inconel 625
Code: T TFE Soft Seats		
10	Seat Retainer	316 SST
11	Plug	316 SST
27	Set Screw	316 SST
29	Socket Head Capscrew	316 SST
35	Soft Seat Retainer	316 SST
36	Soft Seat	Flourosint 207
Code: P PEEK Soft Seats		
10	Seat Retainer	316 SST
11	Plug	316 SST
27	Set Screw	316 SST
29	Socket Head Capscrew	316 SST
35	Soft Seat Retainer	316 SST
36	Soft Seat	PEEK
Code: 6 Alloy 6 Trim		
9	Fixed Adjustable Seat Ring	Alloy 6B or 316 SST/Alloy 6B Inlay
27	Set Screw	316 SST
29	Socket Head Capscrew	316 SST
32	Blank Plug	316 SST
33	Plug Face	Alloy 6B
34	Retaining Screw	Inconel 625

Shaft Design

Item	Part Nomenclature	Materials
Code: D or E Indirect Shaft		
16	Actuator Adapter	Steel
20	Hex Head Bolt	Alloy Steel GR B7
21	Regular Lockwasher	Steel
22	Hex Nut	Alloy Steel GR B2
23	Hex Nut	316 SST
Code: E or F Split Shaft		
37	Upper Shaft	As Specified
38	Groove Pin	SST
39	Lower Shaft	As Specified

Shaft Materials

Item	Part Nomenclature	Materials
Code: S 17-4 Hard Shaft		
1	Valve Shaft	17-4 PH SST
28	Drive Pin	17-4 PH SST
Code: I Inconel Shaft		
1	Valve Shaft	Inconel 718
28	Drive Pin	Inconel 718
Code: S PEEK Bearings		
12	Bearing	PEEK
Code: T PEEK Bearings w/Flouraz 797 Seals		
12	Bearing	PEEK
40	Shaft for Bearing Seals	As Specified
41	O-ring	Flouraz 797
Code: 6 Alloy 6B Bearings		
12	Bearing	Alloy 6B
Code: Y Alloy 6B Bearings w/Flouraz 797 Seals		
12	Bearing	Alloy 6B
40	Shaft for Bearing Seals	As Specified
41	O-ring	Flouraz 797

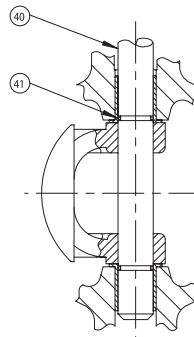

Bearing Seal Construction

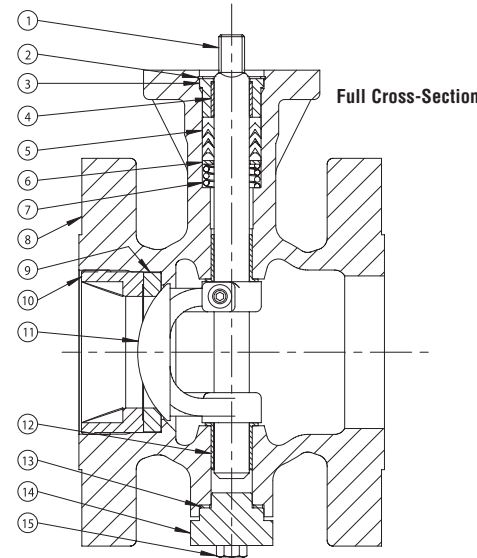

Full Cross-Section

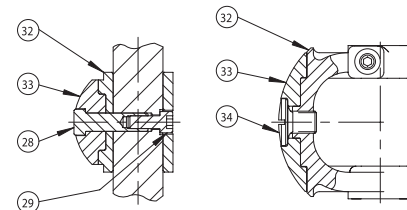

Ceramic or Alloy 6 Plug Construction 1 Inch Valves

Ceramic or Alloy 6 Plug Construction 1.5 - 12 Inch Valves Inseparable Assembly

Packing Materials

Item	Part Nomenclature	Materials
Code: T Teflon V-Ring Packing		
2	Retaining Ring	316 SST
3	Packing Retainer	316 SST
4	Packing Bearing	PEEK
5	V-Ring Packing Set	PTFE
6	Packing Spacer	316 SST
7	Packing Spring	316 SST
Code: G Graphite Packing (Requires Indirect Shaft)		
17	Hex Head Capscrew	SST
18	Packing Flange	316 SST
19	Adjustable Packing Retainer	Alloy 6B
24	Yarn Packing	Graphite
25	Ring Packing	Graphite
26	Packing Spacer	Alloy 6B

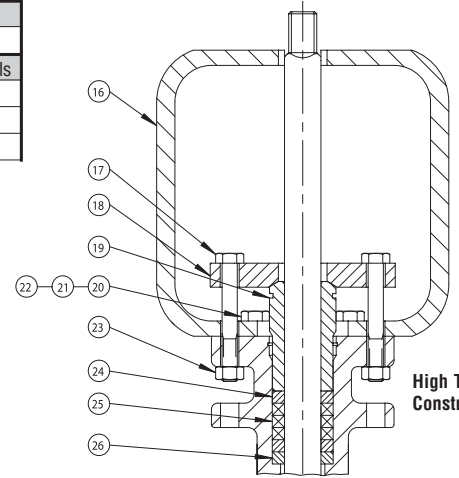

High Temperature Construction

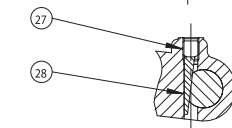

Plug & Shaft Construction 1.5 - 12 Inch Valves

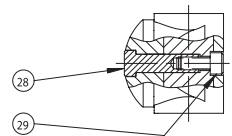

Plug & Shaft Construction 1 Inch Valves

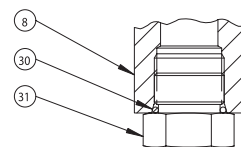

Bottom Plug Construction 1 - 1.5 Inch Valves

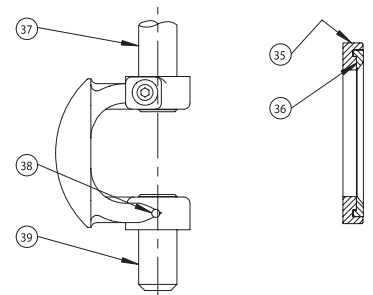

Split Shaft Construction 1.5 - 12 Inch Valves Plug & Shafts are matched sets

Soft Seat Construction Inseparable Assembly

Performance Characteristics

Body Pressure-Temperature Ratings

Body Pressure – Temperature Rating conform to ANSI based on body/flange rating and body material. As the fluid temperature increases, the maximum allowable internal pressure decreases. Verify maximum pressures and temperatures prior to selecting body material and body/flange rating.

Body Pressure-Temperature Ratings:				
Temperature (F)	150 FLG WCB	300 FLG WCB	150 FLG CF8M	300 FLG CF8M
+32° To 100°	285	740	275	720
150°	272	707	255	670
175°	266	691	245	645
200°	260	675	235	620
225°	252	670	230	605
250°	245	665	225	590
275°	237	660	220	575
300°	230	655	215	560
325°	222	650	210	548
350°	215	645	205	537
375°	207	640	200	526

Body Pressure-Temperature Ratings:				
Temperature (F)	150 FLG WCB	300 FLG WCB	150 FLG CF8M	300 FLG CF8M
400°	200	635	195	515
450°	185	617	182	497
500°	170	600	170	480
550°	155	575	155	465
600°	140	550	140	450
650°	125	535	125	445
700°	110	520	110	430
750°	95	505	95	425
800°	80	410	80	420

Pressure ratings are PSIG
For applications below 32° consult factory.

Flowing Differential Pressure

NOTE: Approaching limits for continuous use will reduce trim life. For continuous use, stay within half of rated maximum.

NOTE ON BEARINGS: PEEK Bearings should not be used for temperatures above 450°F or flowing differential pressure above 300 PSIG.

MAXIMUM FLOWING DIFFERENTIAL PRESSURE LIMITS

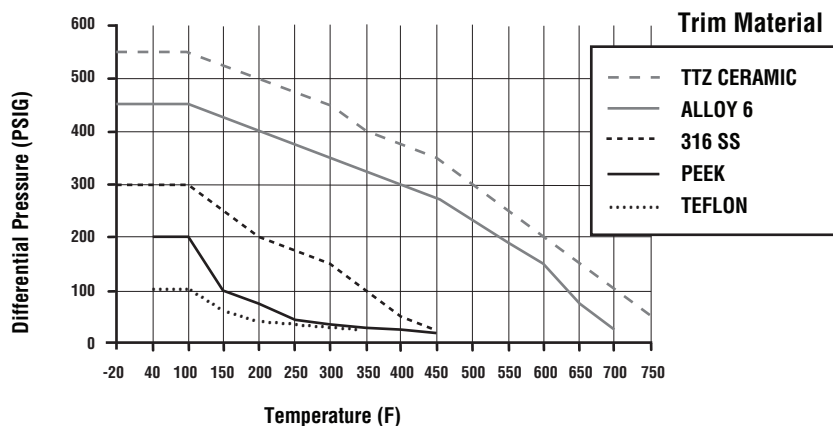

Allowable Seat Leakage

3800 with Metal Seats in any flow direction or TTZ Ceramic Seats Flow-To-Open
ANSI Class IV

3800 with TTZ Ceramic Seats Flow-To-Open
Class IV+
Class IV+ is a proprietary designation of Warren Controls and is not an ANSI/FCI classification.

3800 with PEEK or TFE Soft Seats
ANSI Class VI

Allowable Seat Leakage Classes				
Leakage Class	Maximum Seat Leakage	Test Fluid	Test Pressure	Relative Seat Tightness
Class II	0.5% of rated CV	Water	45 to 60 PSI	1
Class III	0.1% of rated CV	Water	45 to 60 PSI	5
Class IV	0.01% of rated CV	Water	45 to 60 PSI	50
Class IV+	0.0015 ml/min/inch of trim size/ ΔP (PSI)	Water	Max Operating ΔP	150,000
Class V	0.0005 ml/min/inch of trim size/ ΔP (PSI)	Water	Max Operating ΔP	300,000
Class VI	Class VI about 0.9 ml/min*	Air	50 PSI	600,000

*Leakage rate varies by valve size, refer to the Standard ANSI/FCI 70.2.

Steam Table					
Steam Pressure PSIG	Temp. °F	Temp. °C	Sensible Heat BTU/Lb.	Latent Heat BTU/Lb.	Total Heat BTU/Lb.
0	212	100	180	971	1151
10	239	115	207	952	1159
25	266	130	236	934	1170
50	297	147	267	912	1179
75	320	160	290	896	1186
100	338	170	309	881	1190
125	353	178	325	868	1193
150	365	185	339	858	1197
200	387	197	362	838	1200
250	406	208	381	821	1202
300	422	217	399	805	1204
400	448	231	438	778	1216
500	470	243	453	752	1205
600	489	254	475	729	1204

Rectangular Tank Capacity in Gallons

$$\text{Gallons} = \frac{\text{Height} \times \text{Width} \times \text{Length (inches)}}{230}$$

or

$$\text{Gallons} = H \times W \times L \text{ (Ft.)} \times 7.5$$

Circular Tank Storage Capacity in Gallons

$$\text{Storage} = 6D^2 \times L \text{ (Gallons)}$$

Where:

D = Tank Diameter in Feet
L = Length in Feet

Load Sizing Calculations

Glossary of Terms

t = Time in Hours
Cp = Specific Heat of Liquid
S = Specific Gravity of Fluid
W = Weight in Lbs.
 ΔT = Temperature Rise or Fall in °F
 h_{fg} = Latent Heat of Steam

Conversion Factors

1 Lb. Steam / Hr. = 1000 BTU / Hr.
1 Cubic Meter = 264 U.S. Gallons
1 Cubic Foot Water = 62.4 Lbs.
1 PSI = 2.04 Inches of Mercury
1 PSI = 2.3 Feet of Water
1 PSI = 27.7 Inches of Water
1 U.S. Gallon Water = 231 Cubic Inches
1 U.S. Gallon Water = 8.33 Lbs.

Heating Water with Steam

Quick Method

$$\text{Lbs./Hr.} = \frac{\text{GPM}}{2} \times \Delta T$$

Accurate Method

$$\text{Lbs./Hr.} = \frac{\text{GPM} \times 500 \times \Delta T}{h_{fg}}$$

Heating or Cooling Water with Water

$$\text{GPM}_1 = \text{GPM}_2 \times \frac{\text{°F water}_2 \text{ temp. rise or drop}}{\text{°F water}_1 \text{ temp. rise or drop}}$$

Heating or Cooling Water

$$\text{GPM} = \frac{\text{BTU / Hr.}}{(\text{°F water temp. rise or drop}) \times 500}$$

Heating Oil with Steam

$$\text{Lbs./Hr.} = \frac{\text{GPM}}{4} \times (\text{°F oil temp. rise})$$

Heating Air with Water

$$\text{GPM} = 2.16 \times \frac{\text{CFM} \times (\text{°F air temp. rise})}{1000 \times (\text{°F water temp. drop})}$$

Heating Liquids with Steam

$$\text{Lbs./Hr.} = \frac{\text{GPM} \times 60 \times \text{Cp} \times \text{W}}{h_{fg}} \times \Delta T$$

Heating Liquids in Steam Jacketed Kettles

$$\text{Lbs./Hr.} = \frac{\text{GPM} \times \text{Cp} \times \text{S} \times 8.33}{h_{fg} \times t} \times \Delta T$$

General Liquid Heating

$$\text{Lbs./Hr.} = \frac{W \times \text{Cp}}{h_{fg} \times t} \times \Delta T$$

Heating Air with Steam

$$\text{Lbs./Hr.} = \frac{\text{CFM}}{900} \times \Delta T$$

Flow Coefficients (Cv) Versus Travel – Flow to Open

Flow-To-Open:

Most general service applications will benefit from the flow to open direction. Smoother transitions from close to open and greater ability to accommodate larger pressure drops prior to the onset of cavitation are prime benefits as compared to flow to close operation.

		Valve		3800 Flow Coefficients (Cv) Flow to Open									
		Valve Size (IN)	Port Size	% Stroke									
				10	20	30	40	50	60	70	80	90	100
1	Thru Shaft	Reduced	Full	0.90	1.70	3.00	4.50	6.20	8.00	10.0	12.4	14.7	17.3
			1SR	0.60	1.20	2.00	3.00	4.20	5.40	6.70	8.20	9.80	11.5
			2SR	0.40	0.80	1.30	2.00	2.80	3.60	4.50	5.50	6.50	7.70
			3SR	0.30	0.50	0.90	1.30	1.80	2.40	3.00	3.70	4.40	5.10
1.5	Thru Shaft	Reduced	Full	3.00	6.00	10.0	15.0	20.0	26.0	32.0	40.0	48.0	56.0
			1SR	1.90	3.70	6.50	9.70	13.0	17.0	22.0	27.0	32.0	37.0
			2SR	1.20	2.50	4.30	6.50	9.00	12.0	14.0	18.0	21.0	25.0
			3SR	0.80	1.70	2.90	4.30	6.00	7.70	9.60	12.0	14.0	17.0
1.5	Split Shaft	Reduced	Full	5.00	11.0	19.0	29.0	40.0	51.0	64.0	79.0	94.0	110
			1SR	3.70	7.30	13.0	19.0	26.0	34.0	43.0	52.0	62.0	73.0
			2SR	2.40	4.90	8.50	13.0	18.0	23.0	28.0	35.0	42.0	49.0
			3SR	1.60	3.30	5.60	8.50	12.0	15.0	19.0	23.0	28.0	33.0
2	Thru Shaft	Reduced	Full	4.00	8.00	15.0	22.0	30.0	39.0	49.0	60.0	71.0	84.0
			1SR	2.80	5.60	9.70	15.0	20.0	26.0	32.0	40.0	48.0	56.0
			2SR	1.90	3.70	6.50	9.70	13.0	17.0	22.0	27.0	32.0	37.0
			3SR	1.20	2.50	4.30	6.50	9.00	12.0	14.0	18.0	21.0	25.0
2	Split Shaft	Reduced	Full	7.00	14.0	24.0	35.0	49.0	63.0	79.0	97.0	116	136
			1SR	4.50	9.10	16.0	24.0	33.0	42.0	53.0	65.0	77.0	91.0
			2SR	3.00	6.00	10.5	16.0	22.0	28.0	35.0	43.0	51.0	60.0
			3SR	2.00	4.00	7.00	10.5	15.0	19.0	23.0	29.0	34.0	40.0
3	Thru Shaft	Reduced	Full	9.00	18.0	31.0	47.0	65.0	84.0	104	129	153	180
			1SR	6.00	12.0	21.0	31.0	43.0	56.0	70.0	86.0	102	120
			2SR	4.00	8.00	14.0	21.0	29.0	37.0	46.0	57.0	68.0	80.0
			3SR	2.70	5.30	9.20	14.0	19.0	25.0	31.0	38.0	45.0	53.0
3	Split Shaft	Reduced	Full	13.0	27.0	47.0	70.0	97.0	126	157	193	230	270
			1SR	9.00	18.0	31.0	47.0	65.0	84.0	104	129	153	180
			2SR	6.00	12.0	21.0	31.0	43.0	56.0	70.0	86.0	102	120
			3SR	4.00	8.00	13.8	21.0	29.0	37.0	46.0	57.0	68.0	80.0
4	Thru Shaft	Reduced	Full	17.0	35.0	61.0	91.0	126	163	203	250	298	350
			1SR	11.7	23.0	40.0	61.0	84.0	108	135	167	198	233
			2SR	7.80	16.0	27.0	40.0	56.0	72.0	90.0	111	132	156
			3SR	5.20	10.0	18.0	27.0	37.0	48.0	60.0	74.0	88.0	104
4	Split Shaft	Reduced	Full	26.0	51.0	89.0	133	185	239	298	367	436	513
			1SR	17.1	34.0	59.0	89.0	123	159	198	245	291	342
			2SR	11.4	23.0	39.0	59.0	82.0	106	132	163	194	228
			3SR	7.60	15.0	26.0	40.0	55.0	71.0	88.0	109	129	152
6	Thru Shaft	Reduced	Full	40.0	80.0	138	208	288	372	464	572	680	800
			1SR	27.0	53.0	92.0	139	192	248	309	381	453	533
			2SR	17.8	36.0	62.0	92.0	128	165	206	254	302	356
			3SR	11.9	24.0	41.0	62.0	85.0	110	137	169	201	237
6	Split Shaft	Reduced	Full	58.0	116	200	301	416	538	670	827	983	1156
			1SR	39.0	77.0	133	200	277	358	447	551	655	771
			2SR	26.0	51.0	89.0	134	185	239	298	367	437	514
			3SR	17.1	34.0	59.0	89.0	123	159	199	245	291	343
8	TS	Full	8	65.0	130	225	338	468	604	754	929	1105	1300
8			86.0	173	299	450	623	804	1003	1237	1471	1730	

Flow Coefficients (Cv) Versus Travel – Flow to Close

Valve		3800 Flow Coefficients (Cv) Flow to Close											
Valve Size (IN)	Port Size	% Stroke											
		10	20	30	40	50	60	70	80	90	100		
1	Thru Shaft	Full	0.90	1.90	3.20	4.90	6.70	8.70	10.8	13.4	15.9	18.7	
		Reduced	1SR	0.60	1.20	2.20	3.20	4.50	5.80	7.20	8.90	10.6	12.5
			2SR	0.40	0.80	1.40	2.20	3.00	3.90	4.80	5.90	7.10	8.30
			3SR	0.30	0.60	1.00	1.40	2.00	2.60	3.20	4.00	4.70	5.50
1.5	Thru Shaft	Full	3.00	6.00	11.0	16.0	22.0	29.0	36.0	44.0	53.0	62.0	
		Reduced	1SR	2.10	4.10	7.20	10.7	15.0	19.0	24.0	30.0	35.0	41.0
			2SR	1.40	2.80	4.80	7.20	9.90	13.0	16.0	20.0	23.0	28.0
			3SR	0.90	1.80	3.20	4.80	6.60	8.50	10.7	13.0	16.0	18.0
1.5	Split Shaft	Full	6.00	12.0	21.0	32.0	44.0	57.0	71.0	87.0	104	122	
		Reduced	1SR	4.10	8.10	14.0	21.0	29.0	38.0	47.0	58.0	69.0	81.0
			2SR	2.70	5.40	9.40	14.0	20.0	25.0	31.0	39.0	46.0	54.0
			3SR	1.80	3.60	6.30	9.40	13.0	17.0	21.0	26.0	31.0	36.0
2	Thru Shaft	Full	5.00	9.00	16.0	24.0	33.0	43.0	53.0	66.0	78.0	92.0	
		Reduced	1SR	3.10	6.10	10.6	16.0	22.0	29.0	36.0	44.0	52.0	61.0
			2SR	2.00	4.10	7.10	10.6	15.0	19.0	24.0	29.0	35.0	41.0
			3SR	1.40	2.70	4.70	7.10	9.80	13.0	16.0	19.0	23.0	27.0
2	Split Shaft	Full	7.00	15.0	26.0	39.0	54.0	69.0	86.0	107	127	149	
		Reduced	1SR	5.00	9.90	17.0	26.0	36.0	46.0	58.0	71.0	84.0	99.0
			2SR	3.30	6.60	11.5	17.0	24.0	31.0	38.0	47.0	56.0	66.0
			3SR	2.20	4.40	7.60	11.5	16.0	21.0	26.0	32.0	38.0	44.0
3	Thru Shaft	Full	10.0	20.0	34.0	51.0	71.0	92.0	114	141	167	197	
		Reduced	1SR	6.60	13.0	23.0	34.0	47.0	61.0	76.0	94.0	112	131
			2SR	4.40	8.80	15.0	23.0	32.0	41.0	51.0	63.0	74.0	88.0
			3SR	2.90	5.80	10.0	15.0	21.0	27.0	34.0	42.0	50.0	58.0
3	Split Shaft	Full	15.0	29.0	51.0	77.0	106	137	171	211	251	295	
		Reduced	1SR	9.80	20.0	34.0	51.0	71.0	91.0	114	141	167	197
			2SR	6.60	13.1	23.0	34.0	47.0	61.0	76.0	94.0	111	131
			3SR	4.40	8.70	15.0	23.0	31.0	41.0	51.0	62.0	74.0	87.0
4	Thru Shaft	Full	19.0	38.0	66.0	100	138	179	223	275	326	384	
		Reduced	1SR	12.8	26.0	44.0	67.0	92.0	119	148	183	218	256
			2SR	8.50	17.0	30.0	44.0	61.0	79.0	99.0	122	145	171
			3SR	5.70	11.0	20.0	30.0	41.0	53.0	66.0	81.0	97.0	114
4	Split Shaft	Full	28.0	56.0	97.0	146	203	262	327	403	479	563	
		Reduced	1SR	18.8	38.0	65.0	98.0	135	175	218	268	319	375
			2SR	12.5	25.0	43.0	65.0	90.0	116	145	179	213	250
			3SR	8.30	17.0	29.0	43.0	60.0	78.0	97.0	119	142	167
6	Thru Shaft	Full	44.0	87.0	151	227	315	407	507	626	744	875	
		Reduced	1SR	29.0	58.0	101	152	210	271	338	417	496	583
			2SR	19.4	39.0	67.0	101	140	181	226	278	331	389
			3SR	13.0	26.0	45.0	67.0	93.0	121	150	185	220	259
6	Split Shaft	Full	63.0	126	219	329	455	588	734	904	1075	1265	
		Reduced	1SR	42.0	84.0	146	219	304	392	489	603	717	843
			2SR	28.0	56.0	97.0	146	202	261	326	402	478	562
			3SR	18.7	37.0	65.0	97.0	135	174	217	268	319	375
SS/TS	8	Full	71.0	142	246	369	511	660	824	1015	1207	1420	
		Full	94.0	189	327	491	680	879	1096	1351	1607	1890	

Flow-To-Close:

Flow to close operation is generally reserved for erosive service applications. While tighter shut off can be an additional benefit, this is not quantified for levels of tightness above Class IV or Class VI. Further, the tradeoff can be lack of a smooth transition from close to open when pressure differentials are significant especially on larger sizes.

Additional Coefficients

Valve		Flow-to-Open									
Coefficients	Valve Size (IN)	10%	20%	30%	40%	50%	60%	70%	80%	90%	100%
F_L	1 - 2 All Ports	0.89	0.89	0.88	0.88	0.87	0.87	0.86	0.86	0.85	0.85
F_L^2		0.79	0.79	0.77	0.77	0.76	0.76	0.74	0.74	0.72	0.72
K_c		0.60	0.61	0.61	0.62	0.62	0.63	0.64	0.63	0.62	0.59
X_T		0.48	0.50	0.51	0.54	0.57	0.61	0.63	0.62	0.60	0.59
F_L	3 - 4 All Ports	0.87	0.85	0.83	0.82	0.81	0.80	0.79	0.78	0.77	0.76
F_L^2		0.76	0.72	0.69	0.67	0.66	0.64	0.62	0.61	0.59	0.58
K_c		0.60	0.61	0.61	0.62	0.62	0.63	0.61	0.60	0.58	0.57
X_T		0.48	0.53	0.57	0.54	0.52	0.51	0.49	0.48	0.46	0.45
F_L	6 - 8 All Ports	0.94	0.92	0.90	0.87	0.84	0.81	0.78	0.75	0.72	0.69
F_L^2		0.88	0.85	0.81	0.76	0.71	0.66	0.61	0.56	0.52	0.48
K_c		0.60	0.61	0.61	0.62	0.62	0.63	0.60	0.55	0.51	0.47
X_T		0.60	0.57	0.54	0.51	0.48	0.45	0.45	0.43	0.42	0.41

Valve		Flow-to-Close									
Coefficients	Valve Size (IN)	10%	20%	30%	40%	50%	60%	70%	80%	90%	100%
F_L	1 - 2 All Ports	0.96	0.87	0.77	0.74	0.68	0.62	0.62	0.62	0.62	0.62
F_L^2		0.92	0.76	0.59	0.55	0.46	0.38	0.38	0.38	0.38	0.38
K_c		0.88	0.72	0.55	0.52	0.44	0.35	0.35	0.35	0.35	0.35
X_T		0.52	0.54	0.56	0.49	0.42	0.36	0.36	0.36	0.35	0.35
F_L	3 - 4 All Ports	0.83	0.82	0.81	0.75	0.65	0.58	0.58	0.58	0.58	0.58
F_L^2		0.69	0.67	0.66	0.56	0.42	0.34	0.34	0.34	0.34	0.34
K_c		0.61	0.57	0.53	0.52	0.40	0.32	0.32	0.32	0.32	0.32
X_T		0.52	0.54	0.56	0.49	0.42	0.36	0.36	0.36	0.35	0.35
F_L	6 - 8 All Ports	0.92	0.90	0.88	0.81	0.74	0.66	0.63	0.60	0.59	0.58
F_L^2		0.85	0.81	0.77	0.66	0.55	0.44	0.40	0.36	0.35	0.34
K_c		0.77	0.73	0.69	0.62	0.53	0.41	0.39	0.34	0.33	0.33
X_T		0.64	0.55	0.49	0.45	0.42	0.39	0.37	0.35	0.33	0.31

F_L = Recovery Coefficient for All Fluids

K_c = Incipient Cavitation Index for Liquids

X_T = Terminal Pressure Drop for Gaseous State

Flow Curve

The 3800 design inherently has a modified linear flow curve suitable for a wide range of precision control applications.

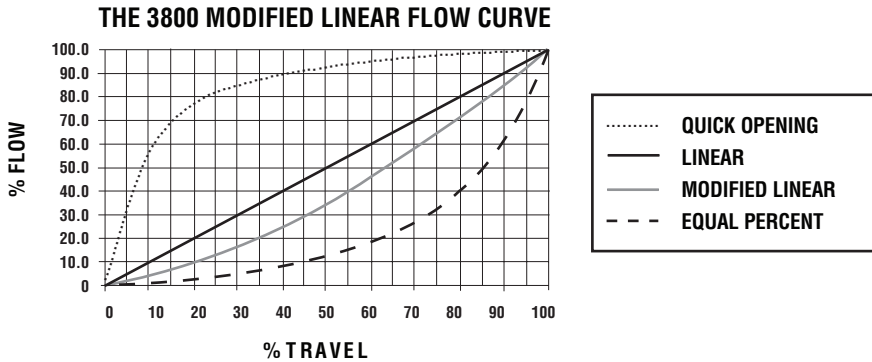

3800 Actuator Torque Requirements - Flow to OPEN

Valve	MAX Torque		Rated Torques (LBS - IN)																
			Holding Torque in LB - IN to Maintain Class IV Shut off																
Valve Size (IN)	17-4 Shaft	Inconel Shaft	Control Valve Inlet Pressure (PSI)																
			Seat Surface: Hard						Bearing Material: PEEK						Packing Material: PTFE				
			10	20	30	40	50	60	75	100	125	150	175	200	250	300	400	500	600
1	480	424	44	46	49	52	55	57	61	68	75	82	89	95	109	123	150	177	204
1-1/2	1080	950	78	85	92	99	106	113	124	142	159	177	195	212	248	283	353	424	495
2	1080	950	100	111	123	134	146	157	174	203	232	261	289	318	376	433	548	664	779
3	1800	1590	203	235	268	301	334	366	415	497	579	661	742	824	988	1151	1478	1805	2132
4	3160	2860	369	448	526	605	683	762	879	1075	1271	1467	1664	1860	2252	2644	3428	4213	4997
6	7020	6190	759	974	1188	1403	1618	1833	2155	2692	3229	3766	4303	4840	5914	6987	9135	11283	13431
8	8460	7460	1229	1646	2063	2479	2896	3313	3938	4981	6023	7065	8107	9149	11234	13318	17486	21655	25824
Valve Size (IN)	17-4 Shaft	Inconel Shaft	Control Valve Inlet Pressure (PSI)																
			Seat Surface: Hard						Bearing Material: Alloy 6						Packing Material: PTFE				
			10	20	30	40	50	60	75	100	125	150	175	200	250	300	400	500	600
1	480	424	49	52	55	59	62	65	70	78	85	93	101	109	125	141	172	204	235
1-1/2	1080	950	87	95	103	111	119	127	138	158	178	198	218	238	277	317	396	476	555
2	1080	950	111	124	137	150	163	176	195	228	260	293	325	357	422	487	617	747	876
3	1800	1590	223	260	296	333	369	405	460	551	642	733	824	915	1097	1278	1642	2006	2370
4	3160	2860	407	493	580	666	753	839	969	1186	1402	1618	1835	2051	2484	2917	3782	4648	5513
6	7020	6190	846	1086	1327	1567	1808	2048	2409	3011	3612	4213	4815	5416	6619	7822	10227	12633	15039
8	8460	7460	1346	1805	2263	2721	3180	3638	4326	5471	6617	7763	8909	10055	12347	14638	19222	23805	28388
Valve Size (IN)	17-4 Shaft	Inconel Shaft	Control Valve Inlet Pressure (PSI)																
			Seat Surface: Hard						Bearing Material: Alloy 6						Packing Material: Graphite				
			10	20	30	40	50	60	75	100	125	150	175	200	250	300	400	500	600
1	480	424	129	132	136	139	142	145	150	158	166	174	182	190	206	222	254	287	319
1-1/2	1080	950	167	175	183	191	199	207	219	239	259	279	299	319	359	399	479	559	638
2	1080	950	191	204	217	230	243	256	276	308	341	373	406	439	504	569	699	830	960
3	1800	1590	374	410	447	483	520	556	611	702	793	885	976	1067	1250	1432	1797	2162	2527
4	3160	2860	617	704	791	877	964	1051	1181	1399	1616	1833	2050	2267	2701	3136	4004	4873	5741
6	7020	6190	1302	1544	1785	2027	2269	2511	2873	3478	4082	4686	5291	5895	7104	8313	10730	13148	15566
8	8460	7460	1803	2262	2722	3181	3641	4100	4790	5938	7087	8236	9385	10534	12832	15129	19725	24320	28915

Valve	MAX Torque		Rated Torques (LBS - IN)																
			Holding Torque in LB - IN to Maintain Class VI Shut off																
Valve Size (IN)	17-4 Shaft	Inconel Shaft	Control Valve Inlet Pressure (PSI)																
			Seat Surface: Soft						Bearing Material: PEEK						Packing Material: PTFE				
			10	20	30	40	50	60	75	100	125	150	175	200	250	300	400	500	600
1	480	424	38	41	43	45	48	50	53	59	65	71	76	82	94	105	128	152	175
1-1/2	1080	950	67	73	79	85	91	96	105	120	135	150	164	179	209	238	297	357	416
2	1080	950	80	89	98	107	116	125	139	161	184	206	229	251	297	342	432	522	612
3	1800	1590	158	183	208	233	258	283	321	383	446	508	571	634	759	884	1134	1385	1635
4	3160	2860	281	339	398	456	515	573	661	807	953	110	1246	1392	1685	1977	2562	3147	3732
6	7020	6190	570	729	887	1045	1204	1362	1599	1995	2391	2787	3182	3578	4370	5161	6744	8327	9910
8	8460	7460	902	1204	1506	1808	2110	2411	2864	3619	4374	5129	5883	6638	8148	9657	12676	15696	18715

RULES FOR USE:

- 1) Select torque requirement table based on flow direction, seat surface, bearing material, and packing material of valve.
- 2) Read across row for valve size to columns for MAX torque. Read **maximum shaft torque** in column for shaft material of valve.
- 3) Read across row for valve size to column for control valve inlet pressure that is equal to or greater than inlet pressure to valve. Read **rated torque value** in that column. For rated torque values in *italics* consult factory for an engineering-application review, and for possible consideration of stronger custom shaft materials, as these choices exceed the MAX torque for standard shafts.
- 4) Proceed to actuator selection tables.

Rated Torques

3800 Actuator Torque Requirements - Flow to CLOSE

Valve	MAX Torque		Rated Torques (LBS - IN)																
			The Greater of Holding Torque or Re-Opening Torque in LB - IN to Maintain Class IV Shut off (Class IV+ with TTZ Ceramic Seat), while allowing re-opening																
Valve Size (IN)	17-4 Shaft	Inconel Shaft	Control Valve Inlet Pressure (PSI)																
			Seat Surface: Hard					Bearing Material: PEEK					Packing Material: PTFE						
			10	20	30	40	50	60	75	100	125	150	175	200	250	300	400	500	600
1	480	424	12	13	15	16	18	19	22	26	30	34	38	42	50	57	73	89	105
1-1/2	1080	950	14	18	22	25	29	33	39	49	58	68	78	87	107	126	165	204	242
2	1080	950	18	26	34	42	50	58	70	90	110	130	150	170	210	250	330	410	489
3	1800	1590	39	63	87	111	135	159	195	255	316	376	436	496	616	736	977	1217	1457
4	3160	2860	82	143	205	267	328	390	482	637	791	945	1099	1253	1562	1870	2486	3103	3720
6	7020	6190	220	395	569	744	919	1094	1356	1793	2230	2667	3104	3541	4415	5289	7037	8786	10534
8	8460	7460	398	750	1103	1455	1808	2160	2689	3571	4452	5334	6215	7096	8859	10622	14148	17674	21199
			Seat Surface: Hard					Bearing Material: Alloy 6					Packing Material: PTFE						
			10	20	30	40	50	60	75	100	125	150	175	200	250	300	400	500	600
1	480	424	12	13	15	17	19	20	23	27	31	36	40	44	53	61	78	96	113
1-1/2	1080	950	14	18	22	27	31	35	41	51	62	72	82	93	113	134	175	217	258
2	1080	950	18	27	35	43	52	60	73	93	114	135	156	177	219	260	344	427	510
3	1800	1590	40	65	90	116	141	166	204	267	329	392	455	518	644	770	1021	1273	1524
4	3160	2860	84	148	212	276	341	405	501	661	821	982	1142	1302	1623	1943	2584	3225	3866
6	7020	6190	228	410	593	775	958	1140	1414	1870	2327	2783	3239	3696	4609	5521	7347	9172	10997
8	8460	7460	410	775	1140	1505	1870	2235	2783	3695	4608	5520	6433	7345	9170	10995	14645	18296	21946
			Seat Surface: Hard					Bearing Material: Alloy 6					Packing Material: Graphite						
			10	20	30	40	50	60	75	100	125	150	175	200	250	300	400	500	600
1	480	424	92	94	95	97	99	101	103	108	112	117	121	125	134	143	161	179	196
1-1/2	1080	950	94	98	103	107	111	115	121	132	142	153	163	174	195	216	258	300	341
2	1080	950	98	107	115	124	132	141	154	175	196	217	239	260	302	345	430	515	599
3	1800	1590	190	216	241	266	291	317	355	418	481	544	607	670	797	923	1176	1429	1681
4	3160	2860	294	359	423	488	552	616	713	874	1035	1196	1357	1518	1840	2162	2806	3450	4094
6	7020	6190	684	867	1051	1235	1419	1602	1878	2337	2797	3256	3715	4175	5094	6012	7850	9687	11524
8	8460	7460	866	1232	1599	1965	2331	2697	3247	4162	5078	5993	6909	7824	9655	11486	15148	18811	22473

Valve	MAX Torque		Rated Torques (LBS - IN)																
			The Greater of Holding Torque or Re-Opening Torque in LB - IN to Maintain Class VI Shut off, while allowing re-opening																
Valve Size (IN)	17-4 Shaft	Inconel Shaft	Control Valve Inlet Pressure (PSI)																
			Seat Surface: Soft					Bearing Material: PEEK					Packing Material: PTFE						
			10	20	30	40	50	60	75	100	125	150	175	200	250	300	400	500	600
1	480	424	11	12	13	15	16	17	19	22	24	27	30	33	39	45	56	68	79
1-1/2	1080	950	13	15	18	21	23	26	30	37	44	50	57	64	77	90	117	144	171
2	1080	950	15	21	26	32	37	43	51	64	78	91	105	119	146	173	227	282	336
3	1800	1590	31	47	64	80	96	112	137	177	218	258	299	339	420	501	663	825	987
4	3160	2860	61	103	144	185	227	268	330	433	537	640	743	847	1053	1260	1673	2087	2500
6	7020	6190	162	279	396	513	630	747	923	1215	1508	1801	2093	2386	2971	3556	4727	5897	7067
8	8460	7460	281	516	752	987	1223	1458	1812	2401	2989	3578	4167	4756	5934	7112	9467	11823	14178

RULES FOR USE:

- 1) Select torque requirement table based on flow direction, seat surface, bearing material, and packing material of valve.
- 2) Read across row for valve size to columns for MAX torque. Read **maximum shaft torque** in column for shaft material of valve.
- 3) Read across row for valve size to column for control valve inlet pressure that is equal to or greater than inlet pressure to valve. Read **rated torque value** in that column. For rated torque values in *italics* consult factory for an engineering-application review, and for possible consideration of stronger custom shaft materials, as these choices exceed the MAX torque for standard shafts.
- 4) Proceed to actuator selection tables.

RULES FOR USE:

First obtain rated torque value and maximum shaft torque value from Torque Requirement Tables.

DOUBLE-ACTING, Flow-to-Open or Flow-to-Close (Double Acting Flow to Close Not Recommended):

- 1) Read across air supply columns to find **double acting torque** value equal to or greater than rated torque required.
- 2) Check that the **double acting torque** value is less than or equal to maximum shaft torque.
- 3) Check that actuator model is compatible with valve size. Repeat as necessary to determine actuator model and air supply required.

SINGLE-ACTING SPRING FAIL CLOSED, Flow-to-Open or Flow-to-Close:

- 1) Read down spring column to find **spring-end torque** value equal to or greater than rated torque required.
- 2) Check that **spring-end torque** value is less than or equal to maximum shaft torque.
- 3) Read across air supply columns to find **air-start torque** value equal to greater than 1.5x (times) the spring end torque.

- 4) Check that actuator model is compatible with valve size. Repeat as necessary to determine actuator model, springs per side and air supply required.

Actuator		Rack & Pinion Pneumatic Actuator Torque																		3800	
Valve Size (IN)	Model	Double Acting Torque (IN - LBS)					Spring# Per Side	The following torque values are in IN - LBS and represent full stroke for the Spring Return Units													
		PSI - Actuator						All		40		60		80		100		120			
		40	60	80	100	120		Spring	AIR	AIR	AIR	AIR	AIR	AIR	AIR	AIR	AIR	AIR	AIR		
		Start	End	End	Start	End	Start	End	Start	End	Start	End	Start	End	Start	End	Start	End	Start		
1 - 3	RP73	367	551	734	918	1101	2	199	127	163	235	344	417	525	598	706	779	887	960		
		-	-	-	-	-	3	299	190	63	172	244	353	426	534	607	715	788	896		
		-	-	-	-	-	4	398	253	-	108	145	290	326	471	507	652	688	833		
		-	-	-	-	-	5	498	317	-	45	45	226	226	407	407	588	588	769		
		-	-	-	-	-	6	597	380	-	-	-	162	12	343	307	524	488	706		
		-	-	-	-	-	6	597	380	-	-	-	162	12	343	307	524	488	706		
	RP103	516	774	1032	1290	1548	2	267	189	241	318	495	572	749	826	1002	1080	1256	1334		
		-	-	-	-	-	3	400	284	107	223	361	477	615	731	869	985	1123	1239		
		-	-	-	-	-	4	533	379	-	128	227	382	481	636	735	890	989	1144		
		-	-	-	-	-	5	667	473	-	33	93	287	347	541	601	795	855	1049		
		-	-	-	-	-	6	800	568	-	-	-	192	213	446	467	700	721	954		
		-	-	-	-	-	6	800	568	-	-	-	192	213	446	467	700	721	954		
1 - 8	RP148	740	1109	1479	1849	2219	2	407	260	321	468	685	832	1049	1196	1413	1560	1777	1924		
		-	-	-	-	-	3	611	391	117	337	481	701	845	1065	1209	1429	1573	1793		
		-	-	-	-	-	4	814	521	-	207	277	571	641	935	1005	1299	1369	1663		
		-	-	-	-	-	5	1018	651	-	76	73	440	437	804	801	1168	1165	1532		
		-	-	-	-	-	6	1221	781	-	-	-	309	232	673	596	1037	960	1401		
		-	-	-	-	-	6	1221	781	-	-	-	309	232	673	596	1037	960	1401		
	RP222	1109	1664	2218	2773	3327	2	550	400	489	645	1018	1174	1548	1704	2077	2233	2607	2763		
		-	-	-	-	-	3	826	600	188	426	718	956	1247	1485	1777	2015	2307	2544		
		-	-	-	-	-	4	1101	800	-	200	407	729	936	1259	1466	1789	1995	2318		
		-	-	-	-	-	5	1376	1000	-	-	84	495	614	1025	1144	1554	1673	2084		
		-	-	-	-	-	6	1651	1200	-	-	-	253	281	783	810	1312	1304	1842		
		-	-	-	-	-	6	1651	1200	-	-	-	253	281	783	810	1312	1304	1842		
	RP295	1479	2219	2958	3698	4437	2	814	516	641	939	1369	1667	2097	2395	2825	3123	3552	3850		
		-	-	-	-	-	3	1222	775	234	681	962	1409	1689	2137	2417	2864	3145	3592		
		-	-	-	-	-	4	1629	1033	-	423	554	1150	1282	1878	2010	2606	2738	3334		
		-	-	-	-	-	5	2036	1291	-	164	147	892	874	1620	1602	2348	2330	3075		
		-	-	-	-	-	6	2443	1549	-	-	-	634	467	1361	1195	2089	1922	2817		
		-	-	-	-	-	6	2443	1549	-	-	-	634	467	1361	1195	2089	1922	2817		
4 - 8	RP470	2071	3106	4142	5177	6213	2	1133	681	938	1390	1974	2425	3009	3461	4045	4496	5080	5532		
		-	-	-	-	-	3	1699	1022	371	1049	1407	2084	2443	3120	3478	4155	4514	5191		
		-	-	-	-	-	4	2266	1363	-	708	840	1743	1876	2779	2911	3841	3947	4850		
		-	-	-	-	-	5	2832	1704	-	367	273	1402	1309	2438	2344	3473	3380	4509		
		-	-	-	-	-	6	3398	2044	-	26	-	1061	742	2097	1777	3132	2813	4168		
		-	-	-	-	-	6	3398	2044	-	26	-	1061	742	2097	1777	3132	2813	4168		
	RP586	2933	4399	5865	7331	8798	2	1542	1052	1344	1834	2787	3277	4320	4720	5673	6163	7117	7606		
		-	-	-	-	-	3	2312	1578	573	1308	2016	2751	3459	4194	4902	5637	6345	7080		
		-	-	-	-	-	4	3083	2104	-	781	1245	2224	2688	3667	4131	5111	5574	6554		
		-	-	-	-	-	5	3854	2630	-	255	473	1698	1916	3141	3359	4584	4802	6027		
		-	-	-	-	-	6	4625	3156	-	-	-	1171	1145	2614	2588	4058	4031	5501		
		-	-	-	-	-	6	4625	3156	-	-	-	1171	1145	2614	2588	4058	4031	5501		
6 - 8	RP900	4550	6825	9100	11375	13650	2	2251	1619	2227	2859	4466	5098	6705	7337	8944	9576	11183	11815		
		-	-	-	-	-	3	3376	2428	1101	2049	3340	4288	5579	6527	7818	8766	10057	11005		
		-	-	-	-	-	4	4501	3238	-	1239	2214	3478	4453	5717	6692	7956	8931	10195		
		-	-	-	-	-	5	5627	4047	-	429	1088	2668	3327	4907	5566	7146	7805	9385		
		-	-	-	-	-	6	6752	4856	-	-	-	1858	2200	4097	4439	6336	6678	8575		
		-	-	-	-	-	6	6752	4856	-	-	-	1858	2200	4097	4439	6336	6678	8575		
	RP1213	6066	9099	12132	15165	18198	2	3000	2159	2969	3811	5954	6796	8939	9781	11924	12766	14910	15751		
		-	-	-	-	-	3	4501	3238	1468	2731	4453	5716	7438	8701	10424	11686	13409	11005		
		-	-	-	-	-	4	6001	4317	-	1651	2952	4636	5937	7621	8922	10606	11907	10195		
		-	-	-	-	-	5	7501	5397	-	571	1451	3556	4436	6541	7421	9526	10406	9385		
		-	-	-	-	-	6	9001	6476	-	-	-	2475	2934	5460	5919	8446	8904	8575		
		-	-	-	-	-	6	9001	6476	-	-	-	2475	2934	5460	5919	8446	8904	8575		

SINGLE-ACTING SPRING FAIL OPEN, Flow-to-Open or Flow-to-Close:

- 1) Read down and across air supply columns to find **air-end torque** value equal to or greater than rated torque required.

- 2) Check that **air-end torque** value is less than or equal to maximum shaft torque.

- 3) Corresponding **spring-start torque** value must be equal to or greater than 1.5x (times) the air-end torque.

- 4) Check that actuator model is compatible with valve size. Repeat as necessary to determine actuator model, springs per side, and air supply required.

Actuator Torques

RULES FOR USE:

First **obtain rated torque** value and **maximum shaft torque** value from Torque Requirement Tables.

- 1) Read down torque rating column to find **torque value equal to or greater than rated torque** required.
- 2) Check that **torque value** is **less than or equal to maximum shaft torque**.
- 3) Check that actuator model is compatible with valve size. Repeat as necessary to determine actuator model.

Electric Actuator Torque Chart						
Electric Actuator	Order Code	MAX Torque Rating	Valve Compatibility	Actuator Flange Size	Power (Watts)	Stroke (Secs.)
EOM-3A	EA3	720	1" - 3"	F07	40	22
EOM-3B	EB3	1200	1" - 3"	F07	40	22
EOM-4	E04	3543	4" - 8"	F10	120	22
EOM-5	E05	4429	4" - 8"	F10	120	28
EOM-6	E06	5757	4" - 8"	F10	120	35
EOM-7	E07	8857	6" - 8"	F12	180	46

NOTES

Pneumatic Rack and Pinion

Size	Air Consumption Cu. In/Cycle
RP73	52.5
RP103	67.1
RP148	112.9
RP222	152.6
RP295	218.5
RP470	335.6
RP486	416.2
RP900	762.8
RP1213	872.6

Body:	Extruded Aluminum, Hard Anodized, with One Part Dry Powder Epoxy Polyester Paint
End Caps:	Die Cast Aluminum, with One Part Dry Powder Epoxy Polyester Paint
Fasteners:	304 Stainless Steel
Racks:	Dual, Die Cast Aluminum, Racks with Integral Pistons
Pinion:	One Piece Electroless Plated Steel Pinion
Pinion Bearings:	Upper and Lower, Delrin 500 Encapsulated
Piston Guides:	Delrin 500
Seals:	Buna-N
Travel Stops:	304 Stainless Steel Dual Adjustable
Springs Cartridges:	Fully Encapsulated Epoxy Coated Steel, Delrin/Brass
Action:	Double Acting or Spring Return
Accessory Mounting:	Namur
Ambient Temperature:	-10 to 195°F
Options:	High and Low Temperature Seals (Specify using Special Options or Set-Up Code S)
Accessories:	Declutchable Gear Operators

Pneumatic Rack and Pinion Actuators require a positioner for modulating control.

Electric Quarter Turn

Sizes:	EOM-3A, EOM-3B, EOM-4, EOM-5, EOM-6, EOM-7
Input:	4-20mA closed at 4mA (Factory Default), 1-5V, or 2-10V Reversible
Supply:	120 Vac 1 Phase
Feedback:	4-20mA closed at 4mA (Factory Default), or 2-10V Reversible
Duty Cycle:	75%
Built-in thermal protection (275F)	
Housing:	Aluminum Alloy, Dry Powder Coated
Gear Train:	High Alloy Steel with High Temperature Lubricant. Self-locking
Position Indicator:	Beacon on Actuator Cover
Manual Override:	Non-clutch Design
Conduit Entrance:	(1/2" NPT)
Additional Standard Features:	Internal Heater, Limit Switches
Ambient Temperature:	23 to 140°F
Enclosure, IP 67 (NEMA 4, 4x) Waterproof and Dust Proof	
Approvals:	CE, CSA

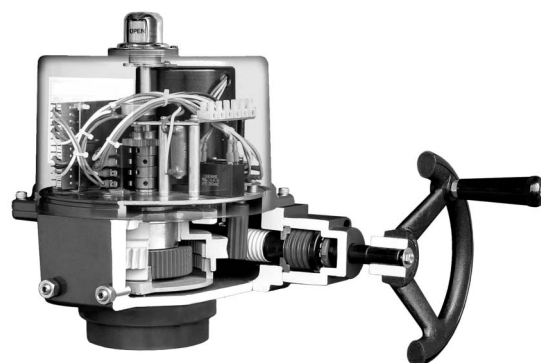
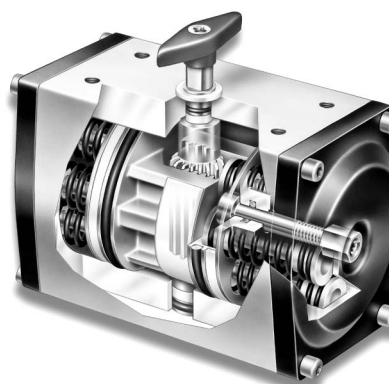

Actuator Interface

Interfaces

Model	ISO 5211-2001 Designation	Actuator Interface
385 1" - 2" Bodies	EN ISO 5211-F07-N-L-11	F07 flange w/ parallel square drive
386 3" Bodies	EN ISO 5211-F07-N-L-14	F07 flange w/ parallel square drive
387 4" Bodies	EN ISO 5211-F07/F10-N-L-17	F07 & F10 flange w/ parallel square drive
388 6" or 8" Bodies	EN ISO 5211-F10-N-L-22	F10 flange w/ parallel square drive
389 6" or 8" Bodies	EN ISO 5211-F12-N-L-22	F12 flange w/ parallel square drive

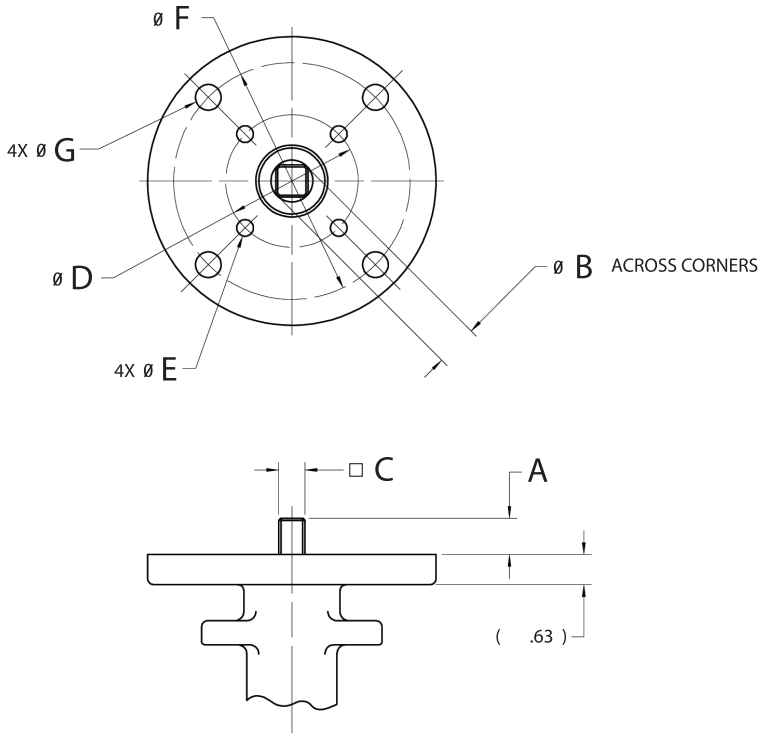

Interface Dimensions

Valve Size (IN)	A	B	C	D	E	F*	G*
8	.94	1.102 1.097	.8646 .8613	4.016	.430 .419	4.921	.540 .528
6	.94	1.102 1.097	.8646 .8613	4.016	.430 .419	4.921	.540 .528
4	.75	.866 .861	.6680 .6653	2.756	.352 .341	4.016	.430 .419
3	.75	.708 .704	.5499 .5472	2.756	.352 .341	-	-
2	.75	.551 .547	.4318 .4291	2.756	.352 .341	-	-
1-1/2	.75	.551 .547	.4318 .4291	2.756	.352 .341	-	-
1	.75	.551 .547	.4318 .4291	2.756	.352 .341	-	-

*F12 flange 6" & 8" valve sizes **389 Models**.

F10 flange 4" valve size **387 Models**.

Piping Orientation

A wide array of acceptable piping orientations allow for maximum flexibility of piping design layout.

Positions ①, ②, and ③ are preferred. Positions ④ and ⑤ are NOT preferred (plug opens into any material that may have settled in bottom of valve.)

Electric Actuator Horizontal Pipe 0-45-90 Piping Orientations

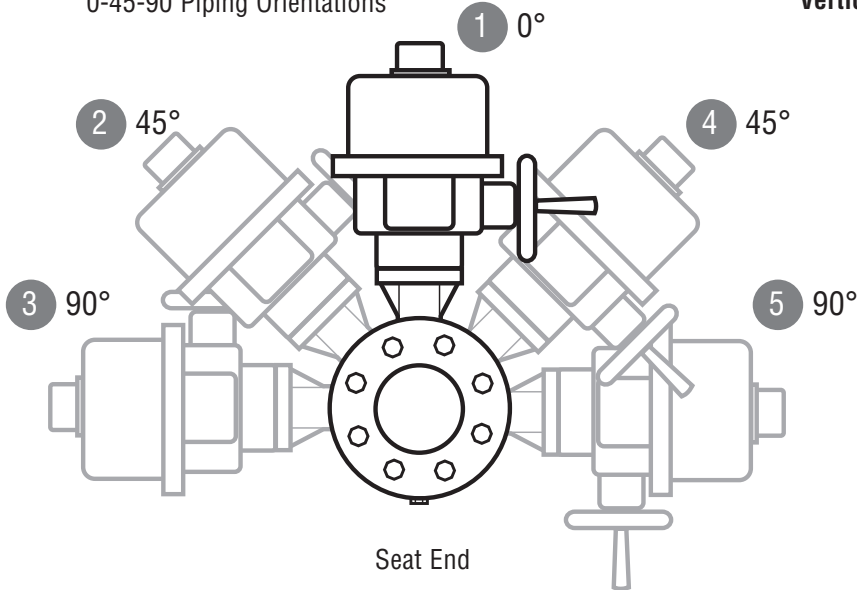

Electric Actuator Vertical Pipe Mount

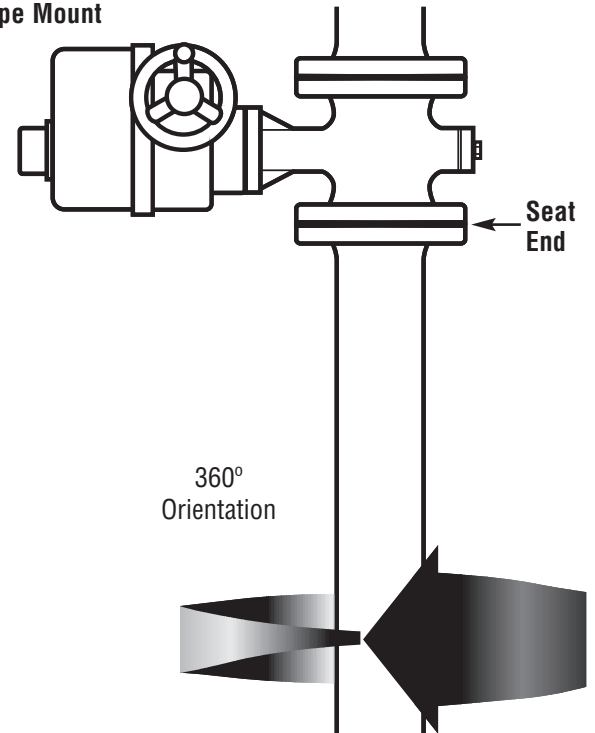

Pneumatic Actuator Horizontal Pipe 0-45-90 Piping Orientations

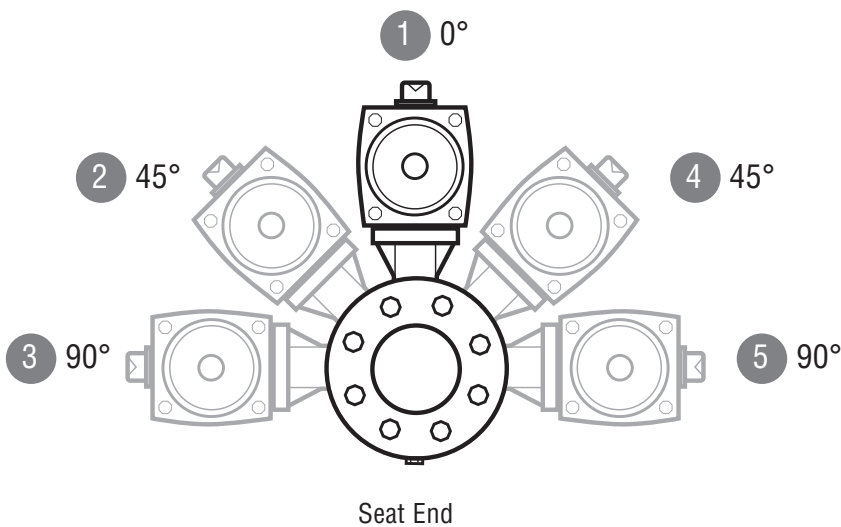

Pneumatic Actuator Vertical Pipe Mount

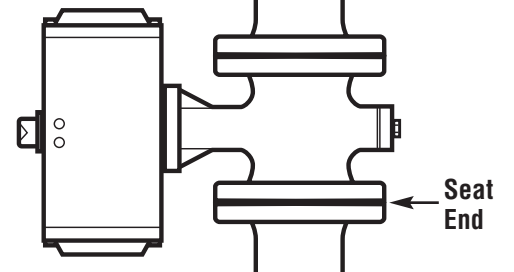

High temperature applications require indirect actuator mount and actuator orientation that is not directly above the valve.

Actuator Orientation & Flow Direction

Pneumatic Rack & Pinion Actuator

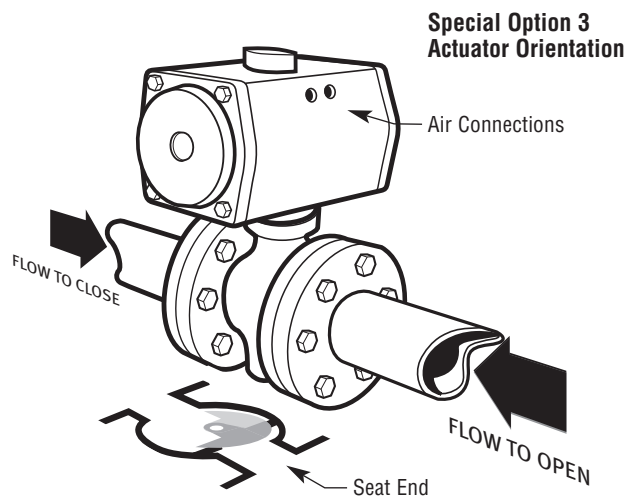
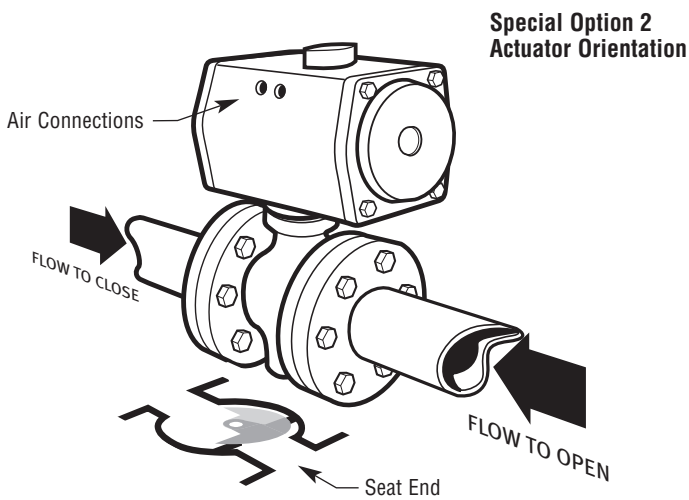
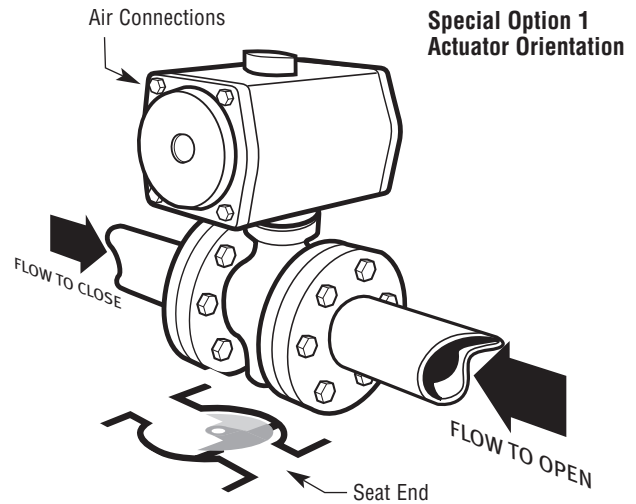
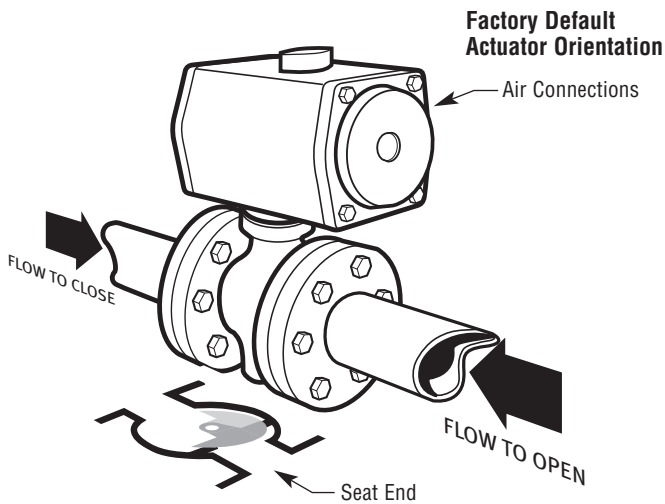

Actuator Orientation

For both the Rack and Pinion Pneumatic, and Electric Actuators, on these two adjacent pages, the factory default and three optional actuator orientations are depicted.

To specify an optional actuator orientation:

1. Select the correct code for the optional actuator orientation from the Special Options Table at the end of the model number string and include it in the order code for the valve.
2. List Actuator Orientation 1, 2, or 3 after the order code on the purchase order.

Actuator Orientation & Flow Direction

Electric Actuator

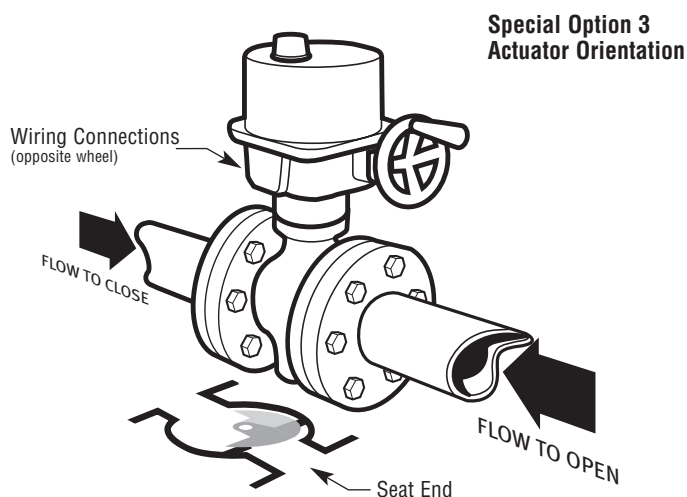
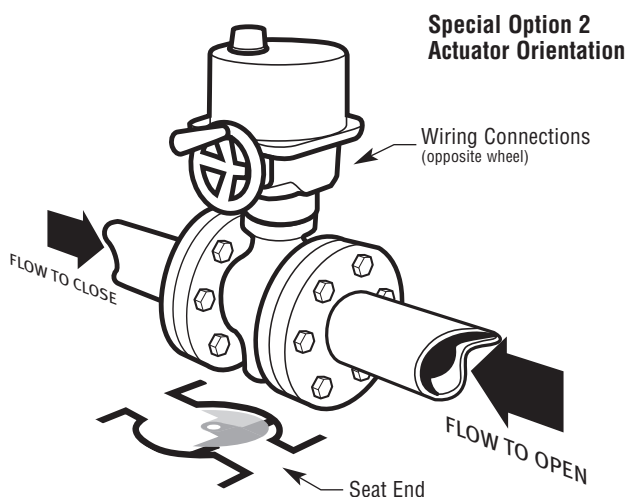
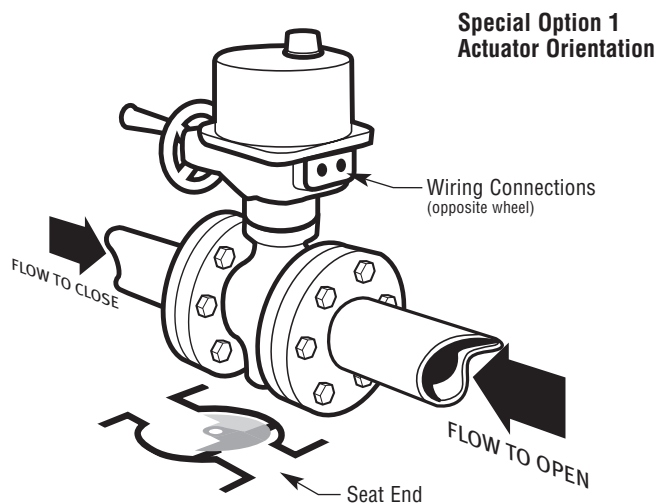
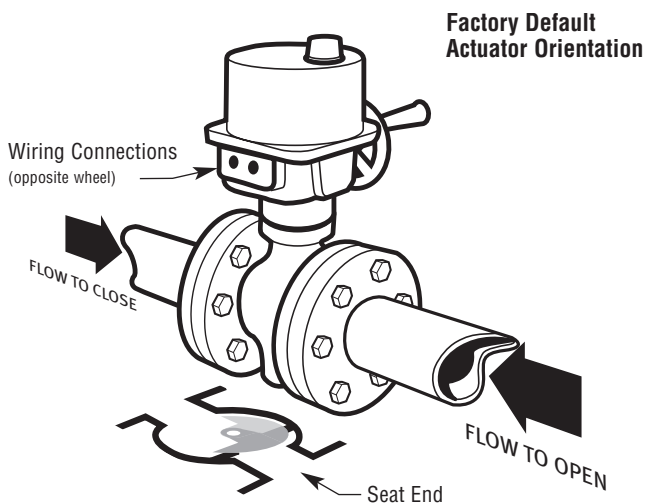

Flow Direction

Flow-To-Open: Most general service applications will benefit from the flow to open direction. Smoother transitions from close to open and greater ability to accommodate larger pressure drops prior to the onset of cavitation are prime benefits as compared to flow to close operation. However, flow-to-open has a slightly smaller Cv as compared to the equivalent flow-to-close valve. If Cv with flow-to-open is borderline, you may want to consider a split-shaft configuration to increase Cv rather than flow-to-close for some applications.

Flow-To-Close: Flow-to-close operation is generally reserved for erosive service applications. While tighter shut off can be an additional benefit, this is not quantified by ANSI for levels of tightness above Class IV or Class VI. Further, the tradeoff can be lack of a smooth transition from close to open when pressure differentials are significant especially on larger sizes. Caution should be observed.

When using TTZ Ceramic trim in the flow-to-close direction, the 3800 can achieve levels of seat tightness that approach ANSI Class V. Warren Controls has designated this elevated level of seat tightness with the proprietary classification Class IV+. For greater detail on relative seat tightness see "Allowable Seat Leakage" on page 5.

Positioners & Accessories

Positioners

Split Ranging with Positioners

Positioners are sometimes used to “Split-Range” two control valves in a parallel configuration within a piping scheme. This technique is used to obtain higher rangeability than could otherwise be achieved with a single control valve. Typically one smaller valve supplying 15% to 35% of total flow is mated with a larger valve supplying 65% to 85% of total flow.

The best-matched pair will each be providing similar rangeability for each respective flow contribution to the manifold. Calculated as maximum flow /minimum controllable flow, the smaller valve should not be attempting to control flow below 5% of stroke. Estimate Cv from Cv tables vs. stroke to calculate this.

The chosen positioners would then have a Low Range signal for the smaller valve and a High Range Signal for the larger valve. With this, a single control signal can be applied to both valves. At mid-signal range, the little valve is completely open while the larger valve is just starting to open. Controlability for wide process set point ranges is dramatically improved.

BLX Models:



BLX Pneumatic

Models: BFP_: Full Range Signal (3-15 PSIG)
BLP_: Low Range Signal (3-9 PSIG)
BHP_: High Range Signal (9-15 PSIG)

Options 2SPDT Limit Switches, 4-20 mA Feedback
Ingress & Corrosion Protection: NEMA, 4X, IP66
Supply Pressure: Pneumatic 145 PSIG Max **Not to exceed actuator rating**
Air Consumption: 0.37 SCFM at 60 PSIG
0.61 SCFM at 100 PSIG

BLX Electro-Pneumatic

Models: BFE_: Full Range Signal (4-20 mA)
BLE_: Low Range Signal (4-12 mA)
BHE_: High Range Signal (12-20 mA)

Options 2SPDT Limit Switches, 4-20 mA Feedback
Ingress & Corrosion Protection: NEMA, 4X, IP66
Supply Pressure: 21.8 to 145 PSIG **Not to exceed actuator rating**
Air Consumption: 0.41 SCFM at 60 PSIG
0.69 SCFM at 100 PSIG

BLX Electro-Pneumatic Intrinsically Safe

Models: BFL_: Full Range Signal (4-20 mA)
BLL_: Low Range Signal (4-12 mA)
BHL_: High Range Signal (12-20 mA)

BLX Electro-Pneumatic Intrinsically Safe (Continued)

Options 2SPDT Limit Switches, 4-20 mA Feedback
Ingress & Corrosion Protection: NEMA, 4X, IP66
Approvals & Ratings:
FM Intrinsically Safe: Class I II III, Div 1, Groups A,B,C,D,E,F,G.
CSA Intrinsically Safe: Class I, Div 1, Groups A, B, C, D.
Class II, Div 1, Groups E, F, G.
Class III.
Class I, Div 2, Groups A, B, C, D.
Class II, Div 2, Groups E, F, G.
Supply Pressure: 30 to 145 PSIG **Not to exceed actuator rating**
Air Consumption: 0.41 SCFM at 60 PSIG
0.69 SCFM at 100 PSIG

BLX Electro-Pneumatic Explosion Proof

Models: BFX_: Full Range Signal (4-20 mA)
BLX_: Low Range Signal (4-12 mA)
BHX_: High Range Signal (12-20 mA)

Options 2SPDT Limit Switches, 4-20 mA Feedback
Ingress & Corrosion Protection: NEMA, 4X, IP66
Approvals & Ratings:
FM Intrinsically Safe: Class I II III, Div 1, Groups A,B,C,D,E,F,G.
Non-Incendive: Class I, Div 2, Groups A,B,C.
Explosion Proof: Class I, Div 1, Groups B,C,D.
Class I II III, Div 1, Groups E,F,G.
CSA Intrinsically Safe: Class I, Div 1, Groups A,B,C,D.
Class II, Div 1, Groups E,F,G.
Class III.
Class I, Div 2, Groups A,B,C,D.
Class II, Div 2, Groups E,F,G.
Explosion Proof: Class I, Div 1, Groups B,C,D.
Class II, Div 1, Groups E,F,G.
Supply Pressure: 30 to 145 PSIG **Not to exceed actuator rating**
Air Consumption: 0.41 SCFM at 60 PSIG
0.69 SCFM at 100 PSIG

BLX Electro-Pneumatic Fail Freeze

Models: BFF_: Full Range Signal (4-20 mA)
BLF_: Low Range Signal (4-12 mA)
BHF_: High Range Signal (12-20 mA)

Options 2SPDT Limit Switches, 4-20 mA Feedback
Ingress & Corrosion Protection: NEMA, 4X, IP66
Supply Pressure: 20 to 100 PSIG Max **Not to exceed actuator rating**
Air Consumption: 0.41 SCFM at 60 PSIG
0.69 SCFM at 100 PSIG

All Models:

Construction: Aluminum Housing with Polyester Powder Coat
Action: Single or Double Acting, Direct or Reverse
Media: Clean Dry Oil Free Air Filtered to 5 micron
Air Connections: 1/4 NPT
Flow Capacity: 19.5 SCFM at 60 PSIG
32.5 SCFM at 100 PSIG
Electrical Connection: 1/2 NPT
Gauges: Input 0-30 PSIG,
Output 0-100 PSIG, Supply 0-100 PSIG,
Housing Black Steel Case with Chrome Ring
Ambient Temperature: -40 to 185°F (Except Fail Freeze -4 to 158°F)
Mounting: Actuator Mounted
Limit Switches and Feedback Options are NEMA 4X, IP66 only, and are not suitable for hazardous locations.

Westlock ICoT Models:



Electro-Pneumatic

Models: 510_: Full Range Signal (4-20 mA)

Options 2SPDT Limit Switches

Intelligent with Keypad

Models: 520_: Full Range Signal (4-20 mA)

Calibration 3 Button Keypad

Options 2SPDT Limit Switches, 4-20 mA Feedback

Intelligent with HART

Models: 530_: Full Range Signal (4-20 mA)

Calibration 3 Button Keypad & HART

Options 2SPDT Limit Switches, 4-20 mA Feedback

Intelligent with Foundation Fieldbus

Models: 540_: Full Range Signal (4-20 mA)

Calibration 3 Button Keypad & Foundation Fieldbus

Options 2SPDT Limit Switches, 4-20 mA Feedback

All Models:

Construction: Engineered Resin Housing

Ingress & Corrosion

Protection: NEMA 4, 4X

Approvals & Ratings: Non-Incentive Groups: Groups A-G, Div. 2

Action: Single or Double Acting, Direct or Reverse

Supply Pressure: 45 to 120 PSIG **Not to exceed actuator rating**

Media: Clean Dry Oil Free Air Filtered to 40 micron

Flow Capacity: 16.2 SCFM at 90 PSIG

Air Consumption: 0.008 SCFM at 90 PSIG

Air Connections: 1/4 NPT

Electrical Connection: 1/2 NPT

Gauges: Supply 0-100 PSIG,

Output 0-100 PSIG

Housing Black Steel Case with Chrome Ring

Ambient Temperature: -40 to 180°F

Mounting: Actuator Mounted

Air Filter Regulators



Models: Type 300, Type 350SS

Output Ranges: Type 300, 0-60, or 0-120 PSIG

Type 350SS, 0-100 PSIG

Supply Pressure: Type 300, 250 PSIG Maximum

Type 350SS, 290 PSIG Maximum

Construction: Type 300, Die-Cast Aluminum with Irridite

and Baked Epoxy Paint

Type 350SS, 316 Stainless Steel

Gauge: Type 300, Output, Housing Steel Painted

Type 350SS, Output, Housing Stainless Steel

Air Connections: 1/4 NPT

Filter: Type 300, 40 micron. Type 350SS, 25 micron

Mounting: Actuator or Positioner Mounted

Solenoids



3-Way solenoids are commonly used to evacuate pneumatic single-acting spring return actuators and block the supply. 4-way solenoids are commonly used to help drive pneumatic double-acting on-off actuators. Several combinations are available, when choosing a solenoid please provide diagram or set-up

Models: For use with Pneumatic Actuators with Positioners
8320G704, EF8320G704, 8320G714, EF8320G714

For use with Pneumatic Actuators without Positioners

8342G501, EF8342G501, 8342G502, EF8342G502

8342G511, EF8342G511, 8342G512, EF8342G512

Construction: (EF)8320G704, 3-Way Brass, Single Solenoid

(EF)8320G714, 3-Way Stainless Steel, Single Solenoid

(EF)8342G501, 4-Way Brass, Single Solenoid

(EF)8342G511, 4-Way Stainless Steel, Single Solenoid

(EF)8342G502, 4-Way Brass, Dual Solenoid

(EF)8342G512, 4-Way Stainless Steel, Dual Solenoid

Locations: 8320G704, 8320G714, 8342G501, 8342G502,

8342G511, & 8342G512 Watertight

Types 1, 2, 3, 3S, 4, and 4X

EF8320G704, EF8320G714, EF8342G501, EF8342G502,

EF8342G501 & EF8342G502 Explosion proof and

Watertight, Types 3, 3S, 4, 4X 6, 6P, 7 & 9

Supply: 120VAC

Ambient Temperature: +32 to 125°F

Air Connections: 1/4 NPT

Electrical Connection: 1/2 NPT, Pigtail Leads

Approvals: CSA, UL, CE

Mounting: Actuator or Positioner Mounted

Special Options and Set-Ups

Air Tubing: Copper Standard, Stainless Steel Optional

Tagging: Stainless Steel Tagging Optional

(Two lines, 24 characters/ line)

Actuator Orientation: Optional positions 1, 2, or 3

For additional special option and set-up requirements consult factory.

Dimensions & Weights

With Electric Actuators

Dimension (IN)		Valve Size (IN)						
		1	1-1/2	2	3	4	6	8
A	150FLG	4	4-1/2	4-7/8	6-1/2	7-5/8	9	9-9/16
	300FLG	4	4-1/2	4-7/8	6-1/2	7-5/8	9	9-9/16
B		2-7/8	3-1/4	3-5/8	4-1/2	5-3/8	6-5/8	7-3/4
C (Standard Direct Actuator Mounting)	EOM-3A & B	14-3/4	15	15-1/8	16-1/8	N/A	N/A	N/A
	EOM-4	N/A	N/A	N/A	N/A	19-1/2	21	22-1/2
	EOM-5	N/A	N/A	N/A	N/A	19-1/2	21	22-1/2
	EOM-6	N/A	N/A	N/A	N/A	19-1/2	21	22-1/2
	EOM-7	N/A	N/A	N/A	N/A	N/A	25-1/8	26-5/8
C (With Hi-Temp Indirect Actuator Mounting)	EOM-3A & B	19-5/8	19-7/8	20	21	N/A	N/A	N/A
	EOM-4	N/A	N/A	N/A	N/A	26-3/8	27-7/8	29-3/8
	EOM-5	N/A	N/A	N/A	N/A	26-3/8	27-7/8	29-3/8
	EOM-6	N/A	N/A	N/A	N/A	26-3/8	27-7/8	29-3/8
	EOM-7	N/A	N/A	N/A	N/A	N/A	32	33-1/2
D	EOM-3A & B	23	23	23	23	N/A	N/A	N/A
	EOM-4	N/A	N/A	N/A	N/A	30-1/2	30-1/2	30-1/2
	EOM-5	N/A	N/A	N/A	N/A	30-1/2	30-1/2	30-1/2
	EOM-6	N/A	N/A	N/A	N/A	30-1/2	30-1/2	30-1/2
	EOM-7	N/A	N/A	N/A	N/A	N/A	27-7/8	27-7/8

N/A = Not Available

Face to face dimensions conform to ANSI/ISA S75.04

Actuator removal clearance
 Above EOM-3A & B allow 6"
 Above EOM-4, 5, & 6 allow 8"
 Above EOM-7 allow 9"

Consult factory for drawings, weights, and dimensions of configurations not shown.

Valve Size (IN)	Weight (LB)			
	Standard		With Hi-Temp Actuator MTG	
	150 FLG	300 FLG	150 FLG	300 FLG
1	20	22	29	31
1-1/2	23	30	32	39
2	20	25	29	34
3	35	50	44	59
4	55	80	76	101
6	100	140	121	161
8	145	200	166	221

Actual shipping weights may vary.

Actuator	Weight (LB)
EOM-3A & B	25
EOM-4	49
EOM-5	49
EOM-6	49
EOM-7	80

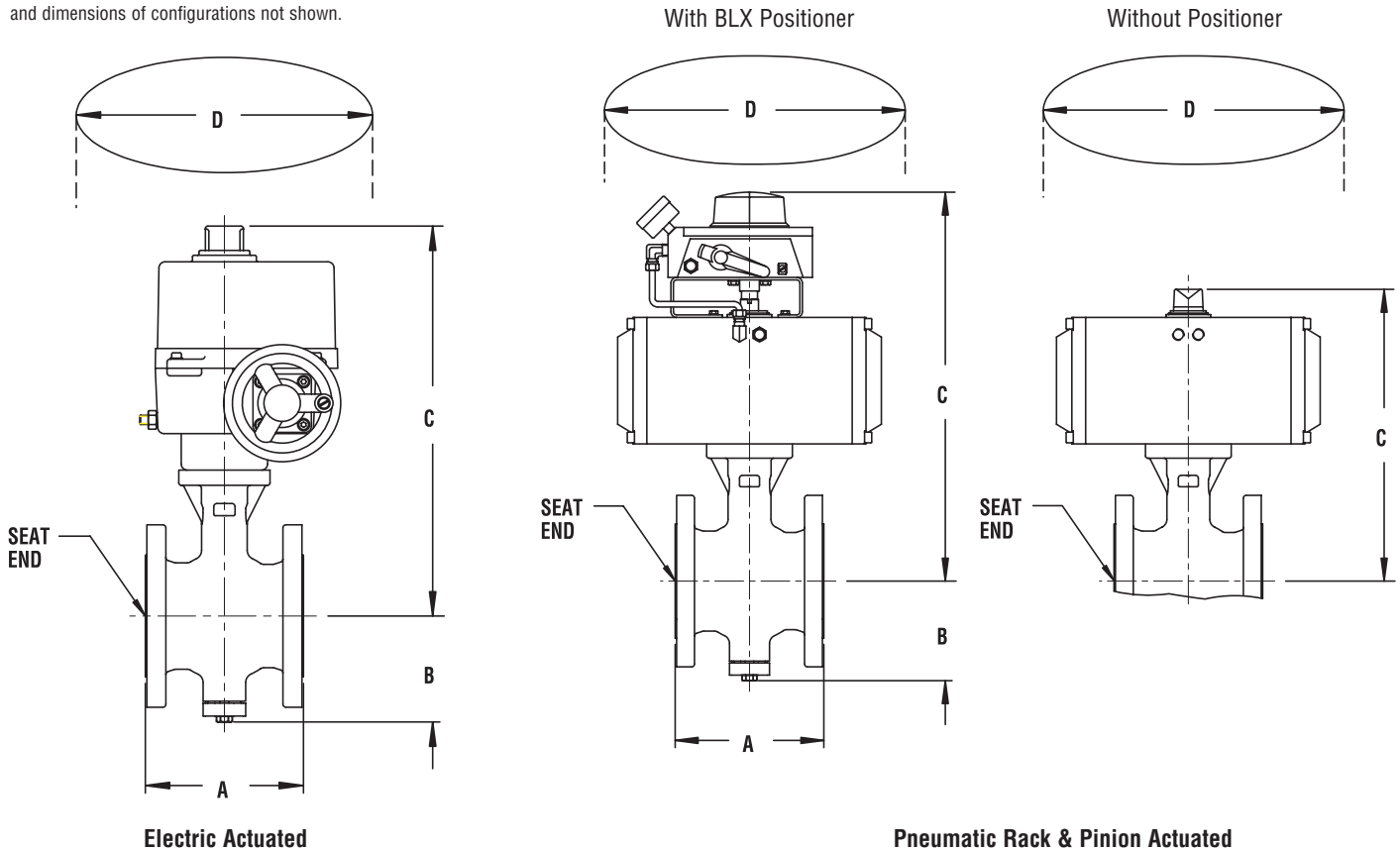

With Pneumatic Rack & Pinion Actuators

Dimension (IN)		Valve Size (IN)						
		1	1-1/2	2	3	4	6	8
A	150FLG	4	4-1/2	4-7/8	6-1/2	7-5/8	9	9-9/16
	300FLG	4	4-1/2	4-7/8	6-1/2	7-5/8	9	9-9/16
B		2-7/8	3-1/4	3-5/8	4-1/2	5-3/8	6-5/8	7-3/4

Without Positioner

C (Standard Direct Actuator Mounting)	RP73	10	10-1/4	10-3/8	11-3/8	N/A	N/A	N/A
	RP103	11-1/4	11-1/2	11-5/8	12-5/8	N/A	N/A	N/A
	RP148	11-3/8	11-5/8	11-3/4	12-3/4	13-3/4	15-1/4	16-3/4
	RP222	11-5/8	11-7/8	12	13	14	15-1/2	17
	RP295	12-3/8	12-5/8	12-3/4	13-3/4	14-3/4	16-1/4	17-3/4
	RP470	N/A	N/A	N/A	N/A	16-1/4	17-3/4	19-1/4
	RP586	N/A	N/A	N/A	N/A	16-7/8	18-3/8	19-7/8
	RP900	N/A	N/A	N/A	N/A	N/A	20-3/8	21-7/8
	RP1213	N/A	N/A	N/A	N/A	N/A	20-3/8	21-7/8
C (With Hi-Temp Indirect Actuator Mounting)	RP73	14-7/8	15-1/8	15-1/4	16-1/4	N/A	N/A	N/A
	RP103	16-1/8	16-3/8	16-1/2	17-1/2	N/A	N/A	N/A
	RP148	16-1/4	16-1/2	16-5/8	17-5/8	20-5/8	22-1/8	23-5/8
	RP222	16-1/2	16-3/4	16-7/8	17-7/8	20-7/8	22-3/8	23-7/8
	RP295	17-1/4	17-1/2	17-5/8	18-5/8	21-5/8	23-1/8	24-5/8
	RP470	N/A	N/A	N/A	N/A	23-1/8	24-5/8	26-1/8
	RP586	N/A	N/A	N/A	N/A	23-3/4	25-1/4	26-3/4
	RP900	N/A	N/A	N/A	N/A	N/A	27-1/4	28-3/4
	RP1213	N/A	N/A	N/A	N/A	N/A	27-1/4	28-3/4

With BLX Positioner (except explosion proof models BxX_)

C (Standard Direct Actuator Mounting)	RP73	14-1/2	14-3/4	14-7/8	15-7/8	N/A	N/A	N/A
	RP103	14-7/8	15-1/8	15-1/4	16-1/4	N/A	N/A	N/A
	RP148	15-3/4	16	16-1/8	17-1/8	18-1/8	19-5/8	21-1/8
	RP222	15-3/4	16	16-1/8	17-1/8	18-1/8	19-5/8	21-1/8
	RP295	16-5/8	16-7/8	17	18	19	20-1/2	22
	RP470	N/A	N/A	N/A	N/A	20-7/8	22-3/8	23-7/8
	RP586	N/A	N/A	N/A	N/A	N/A	22-3/8	23-7/8
	RP900	N/A	N/A	N/A	N/A	N/A	24-5/8	26-1/8
	RP1213	N/A	N/A	N/A	N/A	N/A	24-5/8	26-1/8
C (With Hi-Temp Indirect Actuator Mounting)	RP73	19-3/8	19-5/8	19-3/4	20-3/4	N/A	N/A	N/A
	RP103	19-3/4	19-5/8	20-1/8	21-1/8	N/A	N/A	N/A
	RP148	20-5/8	20-7/8	21	22	25	26-1/2	28
	RP222	20-5/8	20-7/8	21	22	25	26-1/2	28
	RP295	21-1/2	21-3/4	21-7/8	22-7/8	25-7/8	27-3/8	28-7/8
	RP470	N/A	N/A	N/A	N/A	27-3/4	29-1/4	30-3/4
	RP586	N/A	N/A	N/A	N/A	27-3/4	29-1/4	30-3/4
	RP900	N/A	N/A	N/A	N/A	N/A	31-1/2	33
	RP1213	N/A	N/A	N/A	N/A	N/A	31-1/2	33

Add 3/4" to "C" dimension for explosion proof models.

Add 1-7/8" to "C" dimension for mechanical limit switches or 4-20mA feedback.

Dimension (IN)	Actuator	Without Positioner	With BLX Positioner				
			Pneumatic	Electro Pneumatic	Intrinsically Safe	Explosion Proof	Fail Freeze
D	RP73	7-7/8	12-7/8	12-7/8	12-7/8	13-1/8	13
	RP103	9	12-7/8	12-7/8	12-7/8	13-1/8	13
	RP148	9-3/4	12-7/8	12-7/8	12-7/8	13-1/8	13
	RP222	12-1/4	12-7/8	12-7/8	12-7/8	13-1/8	13
	RP295	12-3/4	12-7/8	12-7/8	12-7/8	13-1/8	13
	RP470	15	15	15	15	15	15
	RP586	16	16	16	16	16	16
	RP900	18-7/8	18-7/8	18-7/8	18-7/8	18-7/8	18-7/8
	RP1213	19-7/8	19-7/8	19-7/8	19-7/8	19-7/8	19-7/8

Actuator	Weight (LB)
RP73	6
RP103	8
RP148	11
RP222	15
RP295	19
RP470	31
RP586	35
RP900	62
RP1213	69

BLX Positioner	Weight (LB)
Pneumatic	5-1/2
Electro Pneumatic	6
Intrinsically Safe	7
Explosion Proof	7
Fail Freeze	8

N/A = Not Available

Face to face dimensions conform to ANSI/ISA S75.04

Actuator removal clearance
Allow 3" above pneumatic rack & pinion actuators for removal.

Consult factory for drawings, weights, and dimensions of configurations not shown.

Flange Sizes and Patterns

STEEL FLANGE DIMENSIONS AND DRILLING TEMPLATES 150 AND 300 LB – ANSI B16.5

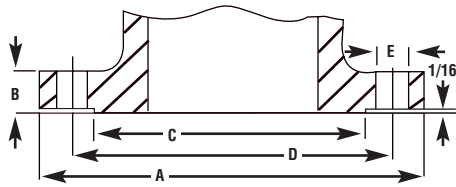

150 AND 300 LB. STEEL

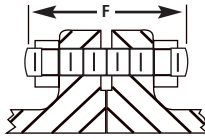

LENGTH OF STUD BOLT

1/16" RAISED
FACE JOINT

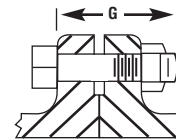

LENGTH OF MACHINE BOLT

Steel Flange Dimensions and Drilling Templates

150 PSI (Gage) Primary Service Pressure Rating

Nominal Pipe Size (IN)	Flange Diameter A	Minimum Flange Thickness B	Diameter of Raised Face C	Diameter of Bolt Circle D	Diameter of Bolt Holes E	Number of Bolts	Diameter of Bolts	Length of Stud Bolts w/2 Nuts F	Length of Machine Bolts G
1	4-1/4	9/16	2	3-1/8	1/2 - 13*	4	1/2	2-1/2	2
1-1/2	5	0.61	2-7/8	3-7/8	1/2 - 13*	4	1/2	2-3/4	2-1/4
2	6	5/8	3-5/8	4-3/4	3/4	4	5/8	3	2-3/4
3	7-1/2	3/4	5	6	3/4	4	5/8	3-1/2	3
4	9	15/16	6-3/16	7-1/2	3/4	8	5/8	3-1/2	3
6	11	1	8-1/2	9-1/2	7/8	8	3/4	3-3/4	3-1/4
8	13-1/2	1-1/8	10-5/8	11-3/4	7/8	8	3/4	4	3-1/2

Dimensions in inches

* Flanges tapped, not enough room for heavy hex nuts.

Steel Flange Dimensions and Drilling Templates

300 PSI (Gage) Primary Service Pressure Rating

Nominal Pipe Size (IN)	Flange Diameter A	Minimum Flange Thickness B	Diameter of Raised Face C	Diameter of Bolt Circle D	Diameter of Bolt Holes E	Number of Bolts	Diameter of Bolts	Length of Stud Bolts w/2 Nuts F	Length of Machine Bolts G
1	4-7/8	11/16	2	3-1/2	5/8 - 11*	4	5/8	3	2-1/2
1-1/2	6-1/8	13/16	2-7/8	4-1/2	7/8	4	3/4	3-1/2	3
2	6-1/2	7/8	3-5/8	5	3/4	8	5/8	3-1/4	3
3	8-1/4	1-1/8	5	6-5/8	7/8	8	3/4	4	3-1/2
4	10	1-1/4	6-3/16	7-7/8	7/8	8	3/4	4-1/4	3-3/4
6	12-1/2	1-7/16	8-1/2	10-5/8	7/8	12	3/4	4-3/4	4-1/4
8	15	1-5/8	10-5/8	13	1	12	7/8	5-1/4	4-3/4

Dimensions in inches

* Flanges tapped, not enough room for heavy hex nuts.

Positioners

Valve Type	Actuator Action	Input Signal			Failure Modes	
		Pneumatic	Electro-Pneumatic	Increasing Signal	Loss of Signal ¹ Valve Fails...	Loss of Supply Valve Fails...
3800	Double Acting	3-15 PSI	4-20 mA	Closes Valve	Open	In Direction of Flow ²
	Spring Fail Open	3-15 PSI	4-20 mA	Closes Valve	Open	Open
	Spring Fail Closed	3-15 PSI	4-20 mA	Opens Valve	Closed	Closed

¹ Valves with Fail Freeze Positioners Fail in Last Position on Loss of Signal.

² Loss of supply to a flow-to-open valve that occurs while the valve is fully seated will probably result in the valve remaining seated. Loss of supply to a flow-to-close valve that occurs while the valve is fully open will probably result in the valve remaining fully open unless the flow rate is extremely high.

Positioner Feedback

Valve Type	Actuator Action	Feedback Signal	Signal Increases as
3800	Double Acting	4-20 mA	Valve Closes
	Spring Fail Open	4-20 mA	Valve Closes
	Spring Fail Closed	4-20 mA	Valve Opens

Positioner Limit Switches

Valve Type	Position	Settings	
		Switch 1	Switch 2
3800	Valve Closed	Closed	Open
	Valve Open	Open	Closed

SOLENOIDS (3-Way and 4-Way Single Solenoid)

Valve Type	Actuator Action	Solenoid Energized	Failure Modes
			Solenoid De-energized, Loss of Signal, or Loss of Air Supply, Valve Fails...
3800	Double Acting	Closes Valve	In Direction of Flow ¹
	Spring Fail Open	Closes Valve	Open
	Spring Fail Closed	Opens Valve	Closed

If the Solenoid is used with a Positioner or an I/P, refer to the Positioner or I/P listings for factory default settings and failure modes with the solenoid not failed.

¹ Loss of supply to a flow-to-open valve that occurs while the valve is fully seated will probably result in the valve remaining seated. Loss of supply to a flow-to-close valve that occurs while the valve is fully open will probably result in the valve remaining fully open unless the flow rate is extremely high.

SOLENOIDS (4-Way Dual Solenoid)

Valve Type	Actuator Action	Solenoid Energized	Failure Modes	
			Solenoids De-energized, Loss of Signals, Valve Fails...	Loss of Air Supply Valve Fails...
3800	Double Acting	Closes Valve (A Energized, B De-Energized)	In Last Position	In Direction of Flow ¹
	Spring Fail Open	Closes Valve (A Energized, B De-Energized)	In Last Position	Open
	Spring Fail Closed	Opens Valve (B Energized, A De-Energized)	In Last Position	Closed

¹ Loss of supply to a flow-to-open valve that occurs while the valve is fully seated will probably result in the valve remaining seated. Loss of supply to a flow-to-close valve that occurs while the valve is fully open will probably result in the valve remaining fully open unless the flow rate is extremely high.

Air Filter Regulators

Output Pressure

As customer specified to max rating of regulator. End user must supply 100 (or 120) psig minimum to the AFR. For air supply above 100 psig special user supplied gage required.

Configurations

1. SELECTIONS Please make a selection from each table of OPTIONS below to make a complete model number string.

38 -

2. OPTIONS

VALVE BODY

Model	Size	Body Material	End Connection	Trim Material	Trim Cv	Shaft Design	Shaft Material	Bearing & Seals	Packing
385 1" - 2" Bodies (EN ISO 5211-F07-N-L-11*)	100 1 inch 150 1-1/2 inch	W WCB F CF8M	F 150 lb. Flanged G 300 lb. Flanged	S 316 Stainless Stl. Z TTZ Ceramic	F Full Port 1 1st Port Reduction 2 2nd Port Reduction 3 3rd Port Reduction	C Thru, Direct D Thru, Indir.	S 17-4 Hard I Inconel	S PEEK 6 Alloy 6 T PEEK w/Fluoraz Seal Y Alloy 6 w/Fluoraz Seal	T Teflon V-ring - Self Adjusting G Adjustable Graphite Indirect Mounting
386 3" Bodies (EN ISO 5211-F07-N-L-14*)	200 2 inch 300 3 inch			T TFE Soft Seats P PEEK Soft Seats		E Split, Direct F Split, Indir.			
387 4" Bodies (EN ISO 5211-F07/F10-N-L-17*)	400 4 inch 600 6 inch			6 Alloy 6					
388 6" or 8" Bodies (EN ISO 5211-F10-N-L-22*)	800 8 inch								
389 6" or 8" Bodies (EN ISO 5211-F12-N-L-22*)									

* ISO 5211-2001 Designations

A C T U A T O R

A C C E S S O R I E S

Flow Direction	Actuator Series	Action	Fail Mode	Declutch. Gear Op.	Positioners	Air Filter Regulators	ASCO Solenoids	Special Options
----------------	-----------------	--------	-----------	--------------------	-------------	-----------------------	----------------	-----------------

0 None
1 Flow to Close
2 Flow to Open
Note: "0" Not Allowed on Actuated Valve

000 None
PNEU.RACK & PINION:
073 Size RP73
103 Size RP103
148 Size RP148
222 Size RP222
295 Size RP295
470 Size RP470
586 Size RP586
900 Size RP900
999 Size RP1213

MANUAL GEAR OP.:
G30 Size GO-30 w. 12" HW (1 - 4")
G50 Size GO-50 w. 12" HW (6")
G51 Size GO-50 w. 18" HW (8")

ELECTRIC 120VAC:
E03 Size EOM-3
E04 Size EOM-4
E05 Size EOM-5
E06 Size EOM-6
E07 Size EOM-7

0 None, Double Act or Gear Op.
Single Acting w. Spring Return
2 4 Springs
3 6 Springs
4 8 Springs
5 10 Springs
6 12 Springs

PNEUMATIC:
S Single Act. Fail Open
T Single Act. Fail Closed
D Double Act. No Fail

ELECTRIC:
1 20mA to Close, Signal Loss Open
2 20mA to Open, Signal Loss Close
3 20mA to Close, Signal Loss As Is
4 20mA to Open, Signal Loss As Is

ELECTRIC:
M Modulating
T On-Off

0 None
6 Size DG6 (1-3")
8 Size DG8 (4")
1 Size DG11 (6 & 8")
NOTE: Only for use as Accessory to Pneumatic R&P Actuator.

0000 None
POSITIONERS:
BxP BLX Pneumatic
BxE BLX ElectroPneumatic
BxI BLX ElectroPneu. Intrn. Safe
BxX BLX ElectroPneu. Exp.Proof
BxF BLX ElectroPneu. Fail Freeze

510 Westlock ICoT Electro-Pneumatic
520 Westlock ICoT Intelligent-Keypad
530 Westlock ICoT Intelligent-Hart
540 Westlock ICoT Found.Fieldbus

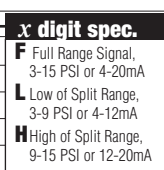

Note: Yellow & Black raised beacons are standard. Red & Black is a special order option for BLX.

Note: Standard pneumatic tubing is copper. SS tubing "T" is optional.
 SS tagging "G" (Two lines, 24 characters/line) is optional.
 SS tubing and tagging together "B" is optional.
 Actuator Orientation "1", "2", or "3" is optional (See page 17 & 18)
 Special Options or Set-Up "S"
 Use this code to identify custom bodies, trim, non-default set ups, etc. not identified by another code. The description of the special option or set-up and complete process conditions must be present on the purchase order.
 If your application requires a special option or set-up contact us for details.

0 None
B Type 300, 0-60 PSI
C Type 300, 0-120 PSI
D Type 350SS, 0-100 PSI

0 None
C 8320G704 3-Way Brass
D 8320G714 3-Way SS
E 8342G501 4-Way Brass
F 8342G511 4-Way SS
G 8342G502* 4-Way Brass
H 8342G512* 4-Way SS
N EF8320G704 3-Way EXP Br.
P EF8320G714 3-Way EXP SS
R EF8342G501 4-Way EXP Br.
S EF8342G511 4-Way EXP SS
T EF8342G502* 4-Way EXP Br.
U EF8342G512* 4-Way EXP SS 120 VAC Coils

0 None
S Special Opts or Set-up
T SS Tubing
G SS Tagging
B SS Tubing and Tagging
1 Actuator Orientation 1
2 Actuator Orientation 2
3 Actuator Orientation 3

**Fail Last Position*

Warren Controls does not assume responsibility for the selection, use, or maintenance of any product. Responsibility for proper selection, use, and maintenance of any Warren Controls product remains solely with the purchaser and end-user.



ACTUATED INDUSTRIAL VALVES

1800 SERIES	2800 SERIES	2900 SERIES	3800 SERIES	5800 SERIES
Heavy Globe Control Valves	Precision Globe Control Valves	High Capacity General Purpose Globe Control Valves	E-Ball Rotary Control Valves	Compact Globe Control Valves
styles: <ul style="list-style-type: none"> • 2-way balanced • 2-way unbalanced • 3-way mixing • 3-way diverting 	styles: <ul style="list-style-type: none"> • 2-way unbalanced • 3-way mixing • 3-way diverting 	styles: <ul style="list-style-type: none"> • 2-way balanced • 2-way unbalanced • 3-way mixing • 3-way diverting 	styles: <ul style="list-style-type: none"> • 2-way rotary <ul style="list-style-type: none"> - flow to open - flow to close 	styles: <ul style="list-style-type: none"> • 2-way cage-retained seat
sizes 2-1/2 to 12 in. class 300 ends 125 FF, 150, 250, 300 RF flg body Cast Iron, WCB, CF8M, NCA, Bronze (ASTM B61) trim 316 SST, Alloy 6 Cv up to 1649 temp. -20° to 800°F body limit to 740 psi shutoff class III, IV rangeability 50:1 <ul style="list-style-type: none"> • Heavy Duty • Severe Service • High Pressure Differentials • Corrosive Materials, Liquids, Gases & Steam • Modulating or On/Off Control 	sizes 1/2 to 2 in. class 250 & 300 ends Butt weld, NPT body Bronze, CF8M trim Bronze, 316SST, 17-4pH, Alloy 6, TFE, PEEK Cv up to 40 temp. -20° to 500°F body limit to 720 psi shutoff class III, IV, VI rangeability 50:1 <ul style="list-style-type: none"> • Economical • Precision Control • Suited for Gases, Steam, or Liquids that are Not Viscous or Solids Bearing 	sizes 2-1/2 to 10 in. class 125 & 250 ends 125 FF, 250 RF flg. body Cast Iron trim Bronze, 300SS, 17-4pH, Alloy 6 Cv up to 960 temp. -20° to 400°F body limit to 400 psi shutoff class II, III, IV rangeability 50:1 <ul style="list-style-type: none"> • High Capacity • General Purpose • Moderate Pressure Drops • Compatible Liquids and Gas, Steam & Water • Modulating or On/Off Control 	sizes 1 to 8 in. class 300 ends 150, 300 RF flg body WCB, CF8M Custom Alloys trim 316 SST, Alloy 6, Ceramic, TFE, PEEK Cv up to 1420 temp. -20° to 800°F body limit to 740 psi shutoff class IV, IV+, VI rangeability 100:1 <ul style="list-style-type: none"> • Eccentric, Segmented Ball • Well Suited for Erosive Service • Various Trim Options Include Ceramic for Slurries or Gritty Materials & Teflon® for Class VI Shutoff 	sizes 1 to 4 in. class 300 ends NPT, 150, 300 RF flg, body WCB, CF8M NCA, Bronze (ASTM B61) trim 316 SST, Alloy 6, TFE, PEEK Cv up to 170 temp. -20° to 800°F body limit to 740 psi shutoff class IV, VI rangeability 50:1 <ul style="list-style-type: none"> • Highly Efficient, Compact Design • High Pressure Drops • Typically Suited for High Force Piston Actuators for Steam, Chemicals & Dirty Fluids

WARREN CONTROLS

2600 Emrick Blvd., Bethlehem, PA 18020-8010 www.WarrenControls.com
 Tel: 800-922-0085 or 610-317-0800 Fax: 610-317-2989