

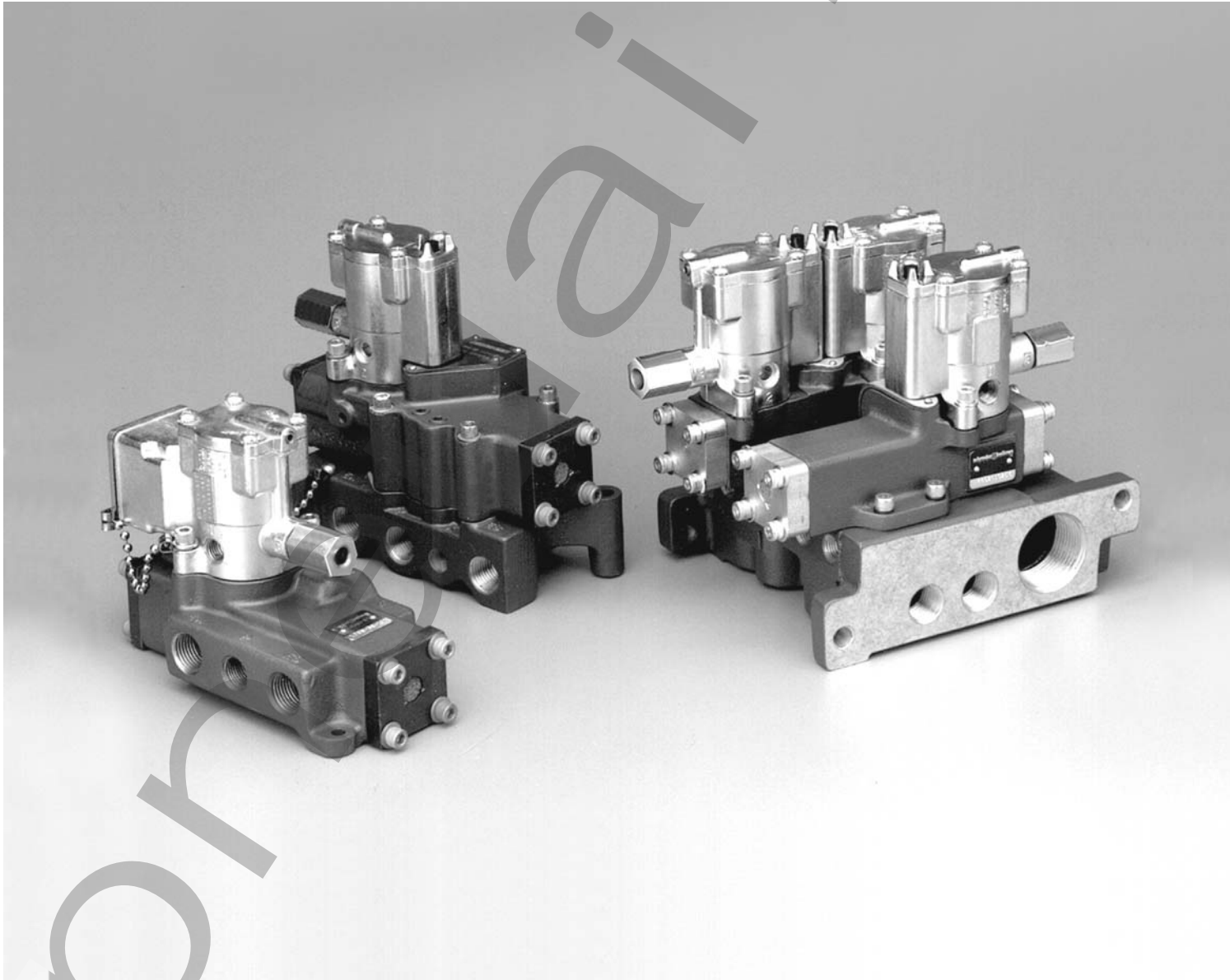

Speed King® SK200 & Valvair II

**Solenoid & Pilot Operated
Directional Spool Valves**

*Catalog VAL-SK-E/USA
April 2004*



Plug-In, Manifold Mounted, 1/4" - 1-1/2" NPT Ports	
Features	2
Valve Model Number System	3-5
2-Position	
Single & Double Solenoid Operated	6-15
Single & Double Remote Air Pilot Operated	16-23
3-Position	
Double Solenoid Operated	24-27
Double Remote Air Pilot Operated	28-31
Manifold Ordering Procedure	32
Manifold Dimensional Data	33-35
Modular Pneumatic Controls	
“Sandwich” Regulators for 3/8" Basic Valves	36-43
Direct Pipe Ported, Inline Mounted, 1/4" - 1-1/4" NPT Ports	
Features	44
Valve Model Number System	45-49
2-Position	
Single & Double Solenoid Operated	50-57
Single & Double Remote Air Pilot Operated	58-65
3-Position	
Double Solenoid Operated	66-69
Double Remote Air Pilot Operated	70-73
Valve Accessories	74-75
Voltage Suffix Codes	75
Service Kit, Conversion Kit, “Quick Reference Guide”	76
Solenoids & Parts	
Plug-In	77
Direct Pipe Ported	78-79
Optional Functions	80
Flow Capacities	81-83
Technical Information	84-87
Standard Product Crossover Information	
SK-200 – 1/4"	88-89
SK-200 – 3/8"	90-91
SK-200 – 1/2"	92-93
Valvair II – 1"	94-95
Specials History and Crossover Information	
SK-200 – 1/4" Specials	96-97
SK-200 – 3/8" Specials	98-99
SK-200 – 1/2" Specials	100-101
Valvair II – 1" Specials	102
Parker A4, A5 Series Specials Crossover Information	103
Offer of Sale	105

Basic Valve Features

- Full Air Operation for fastest response.
- Plug-In Design simplifies maintenance and installation. Reduces downtime. No wiring or plumbing to disturb.
- Solenoids Interchange between all styles of plug-in valves.
- Locking Manual Overrides Standard. Non-locking overrides optional.
- Indicator Lights Standard on 120VAC and 24VDC models.
- Encapsulated Coil designed for low-power consumption and maximum life.
- Plug-In Subbase, Plug-In Manifolds allow design flexibility. A wide range of port sizes, from 1/4" to 1-1/4" NPT are available.
- Field Convertible to External Pilot Supply for vacuum or other services.
- "Oversized" Flow Areas.
- Synthetic Rubber O-Ring Seals are specially compounded for minimum compression and friction for superior wear and abrasion resistance.
- Precision Ground Spool "floats" on O-ring seals. Closed center cross-over design saves air.
- Plug-In "Sandwich" Regulators (Available for specific models) fit between valve and base, increase systems design capabilities.
- CSA - Selected Valves are Canadian Standards Association approved for general purpose use.

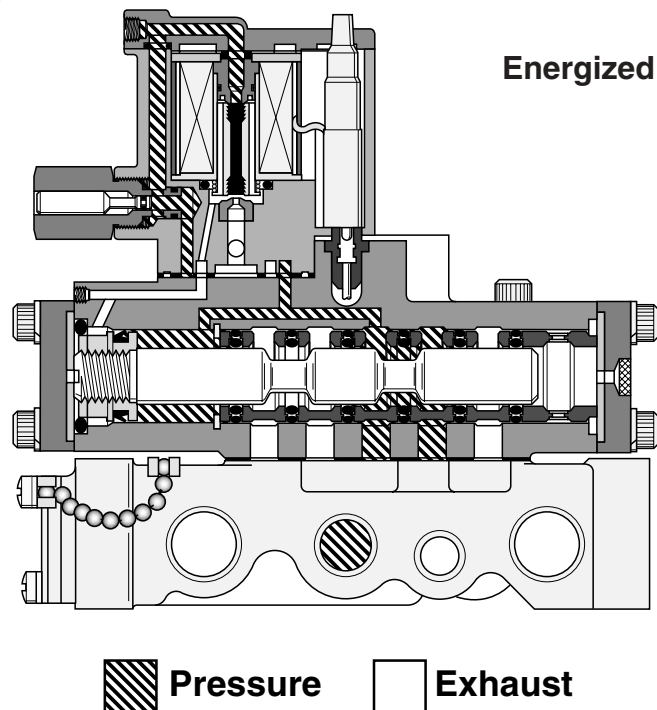
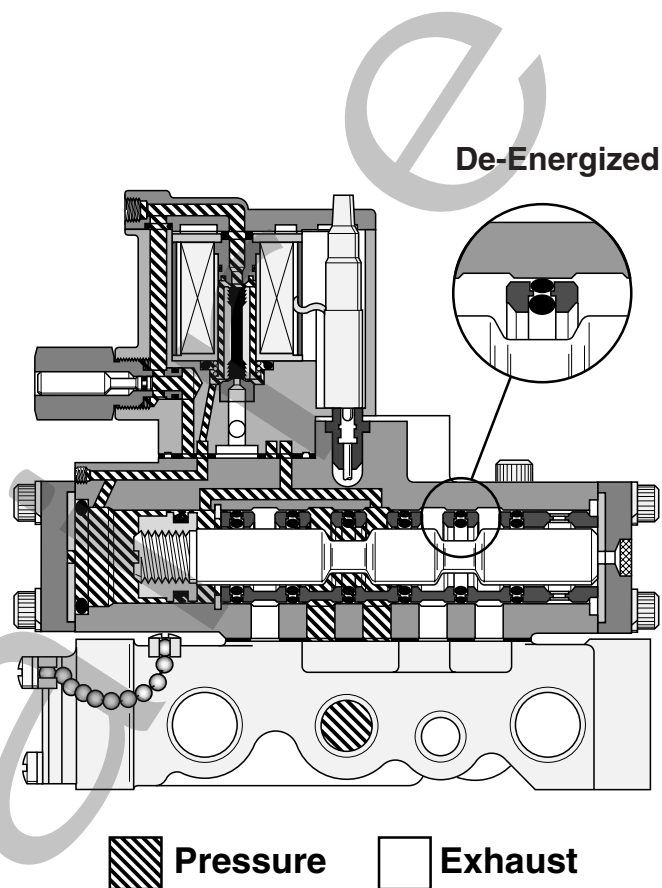

Speed King, SK-200 Valve Model Number System

Lubricated Service 2-Position, Plug-In 1/4" Basic Size

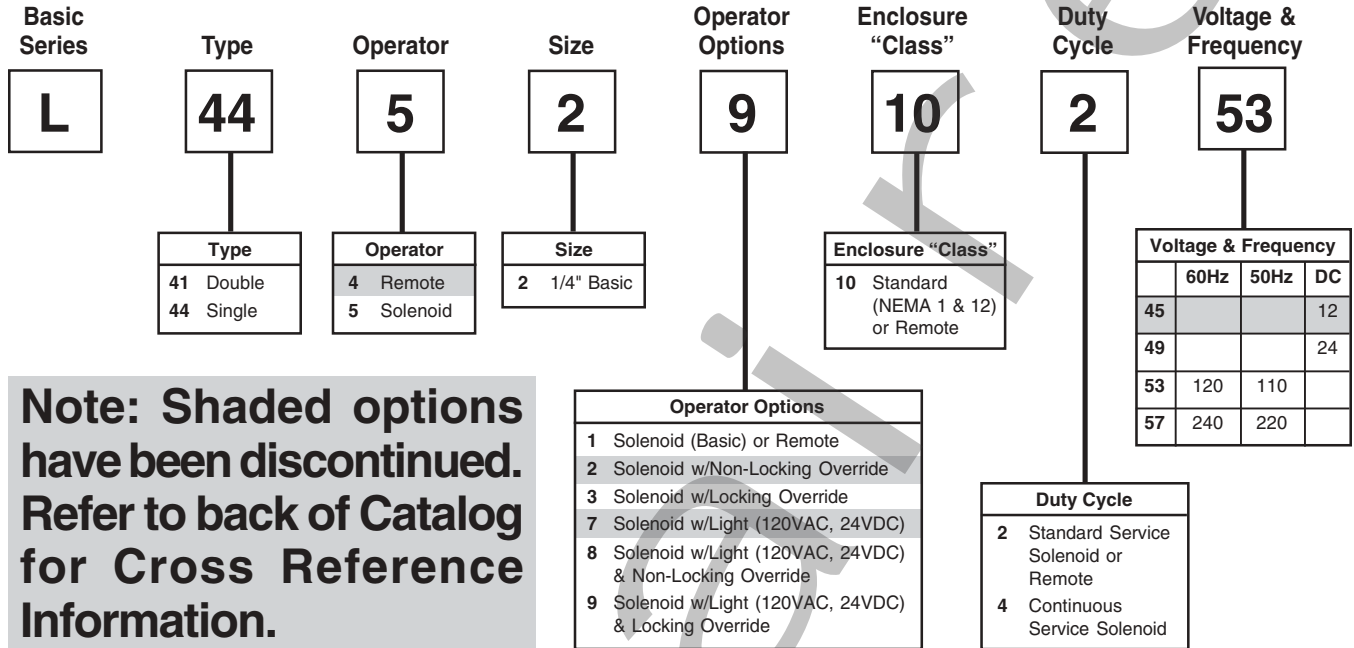

Valvair II Valve Model Number System

Lubricated Non-Lubricated Service 2-Position, Plug-In 3/8" & 1" Basic Size

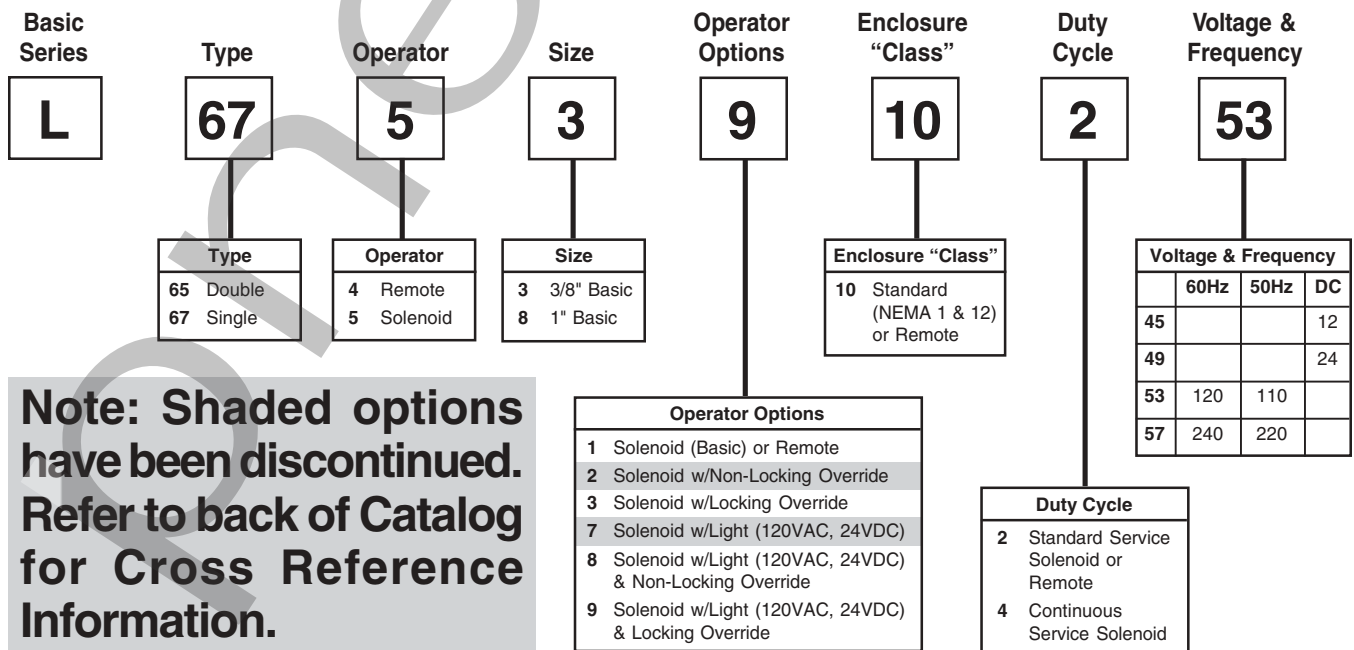

Speed King, SK-200 Valve Model Number System

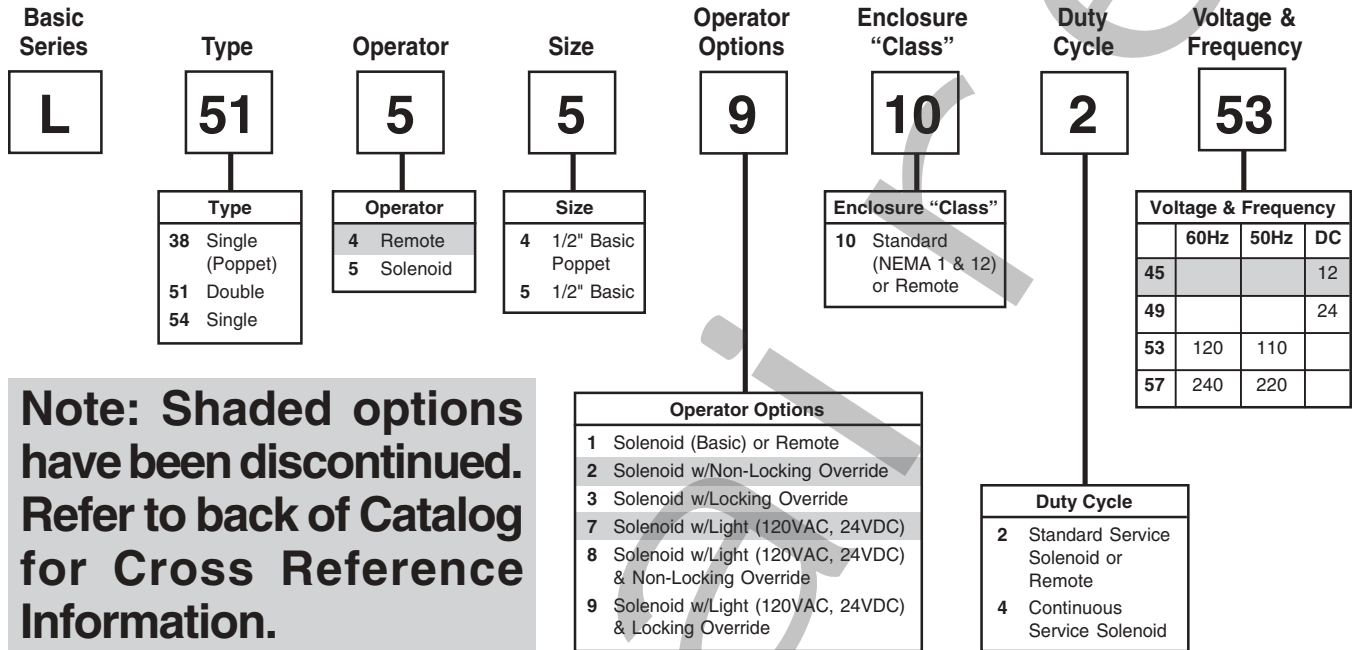

Speed King, SK-200 Valve Model Number System

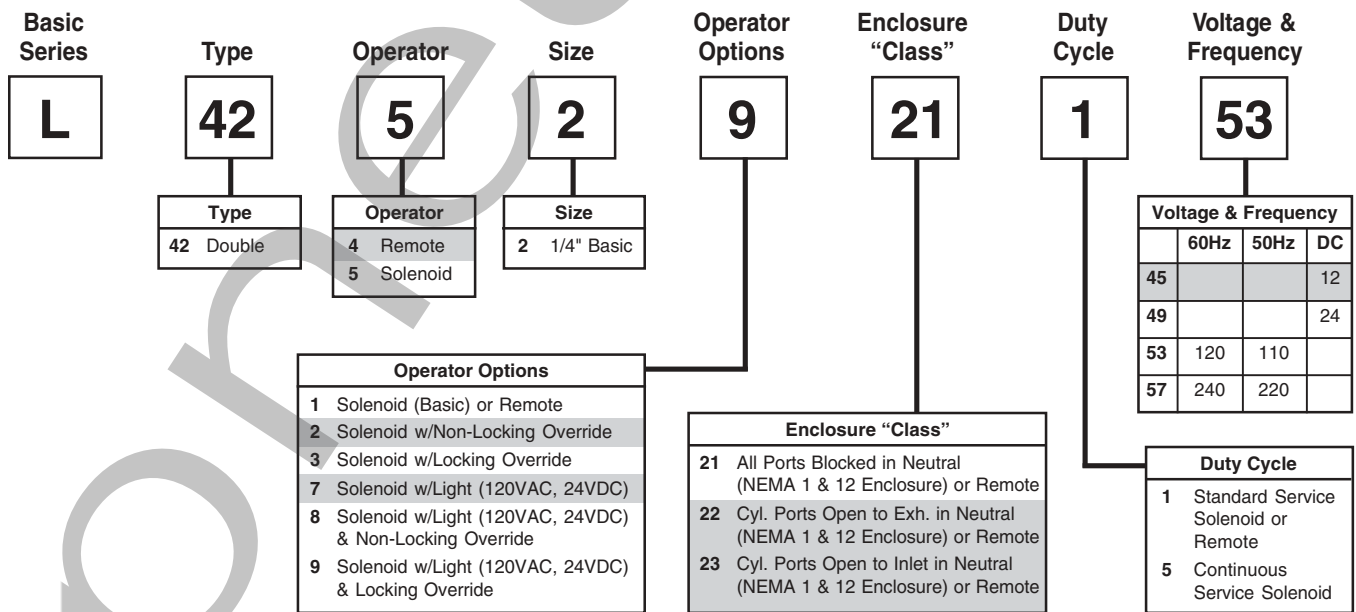

Valvair II Valve Model Number System

Lubricated or Non-Lubricated Service 3-Position, Plug-In 3/8" & 1" Basic Size

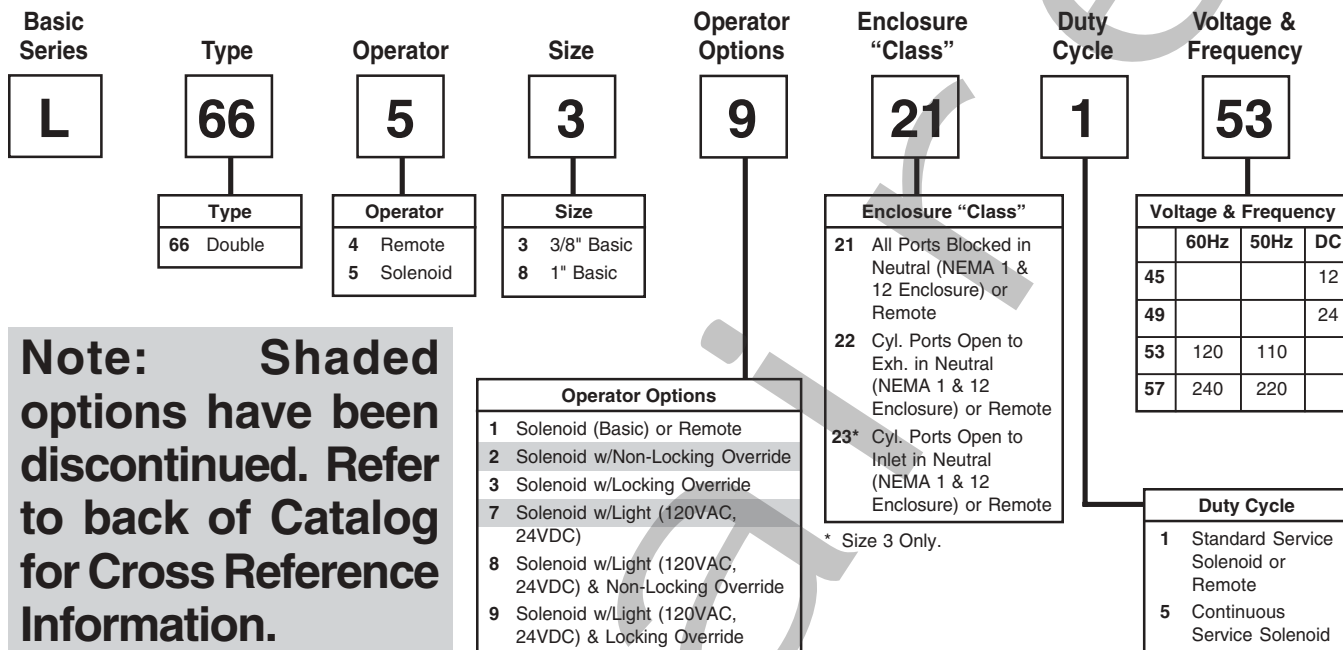

Speed King, SK-200 Valve Model Number System

Lubricated Service 3-Position, Plug-In 1/2" Basic Size

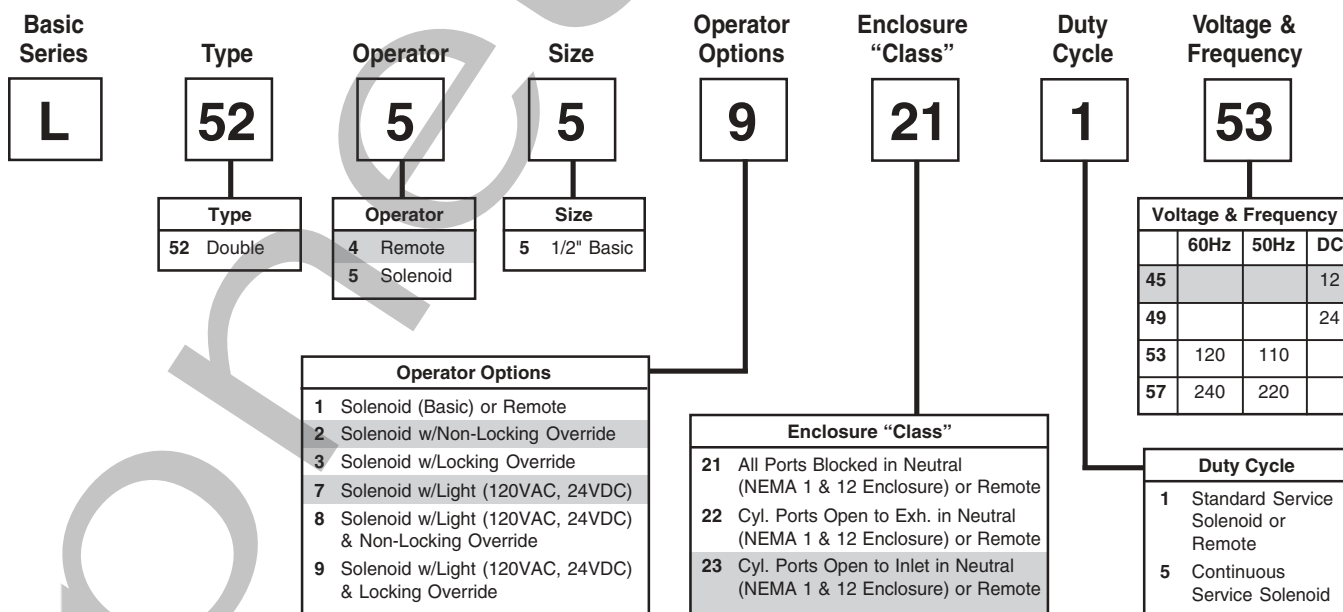

1/4" NPT Ports, Nominal Cv = 1.4

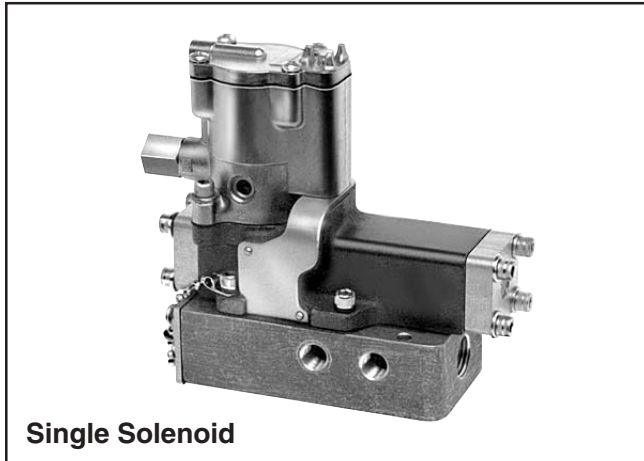

Single Solenoid

Application

These valves may be used to actuate a double acting cylinder. A maintained electrical signal shifts the valve. When this signal is removed the valve returns to its normal condition. For alternate flow path usages, see *Optional Functions* page.

Mounting

These valves are designed for subbase or modular manifold mountings. Electrical connection from valve to base is automatic. Air & electrical connections remain undisturbed if valve is removed. Order from chart below.

Operation: Pressure Service

De-energized (normal condition) – Pressure at Port P is connected to “Cylinder” Port A. “Cylinder” Port B is connected to “Exhaust” Port E.

Energized (maintained signal applied) – Pressure at Port P is connected to “Cylinder” Port B, “Cylinder” Port A is connected to “Exhaust” Port E.

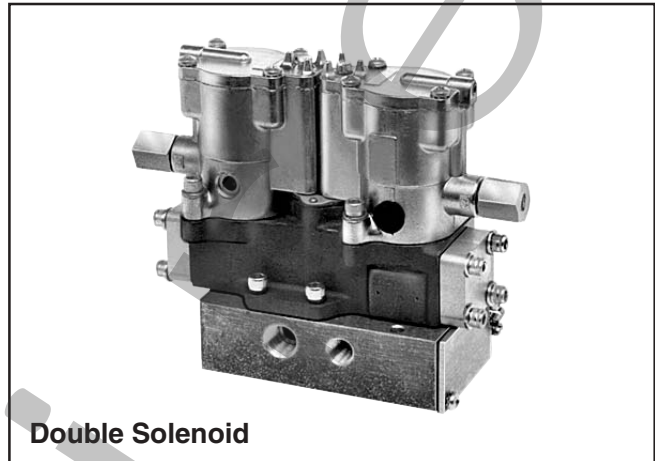
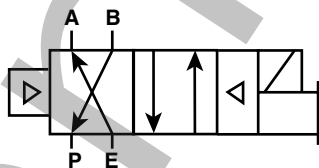

Double Solenoid

Application

These valves may be used to actuate double acting cylinders. A “momentary” electrical signal (exceeding .03 seconds) applied to one of the solenoids shifts the valve. It will remain in this position until a “momentary” signal is applied to the other solenoid. For alternative flow path usages, service, see *Optional Functions* page.

Mounting

These valves are designed for subbase or manifold mountings. Electrical connection from valve to base is automatic. Air & electrical connections remain undisturbed if valve is removed. Axis of main valve spool to be in horizontal plane. Order from chart below.

Operation: Pressure Service

With solenoid “A” having been energized last – Pressure at Port P is connected to “Cylinder” Port A. “Cylinder” Port B is connected to “Exhaust” Port E.

Energize solenoid “B” (momentary) – Pressure at Port P is connected to “Cylinder” Port B. “Cylinder” Port A is connected to “Exhaust” Port E.

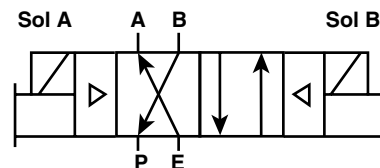

Model Selection

Note: Shaded units are no longer available.

Valve Only		Voltage	Subbase (Side Ports)	Manifold 2 Station ▲ (End & Bottom Ports)	Manifold 3 Station ▲ (End & Bottom Ports)	Port Size (NPT)
Single Solenoid	Double Solenoid					
L445 29 102 53	L415 29 102 53	120V 60Hz 110V 50Hz	K022 097	K142 077	K142 076	1/4"
L445 23 102 **	L415 23 102 **	Other				

See page 3 for variations and (**) voltage codes.

▲ - Manifolds include mounting hardware.

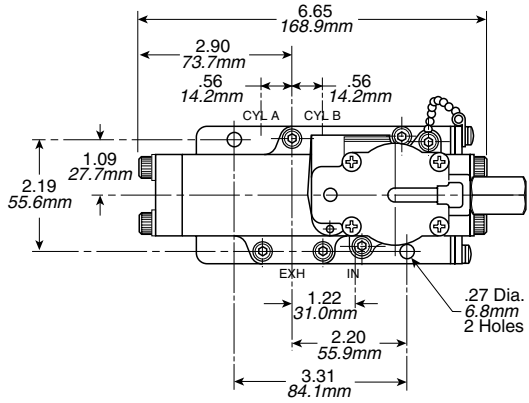

Single Solenoid

See Manifold Section for Manifold Dimensional Data

Wiring Diagram

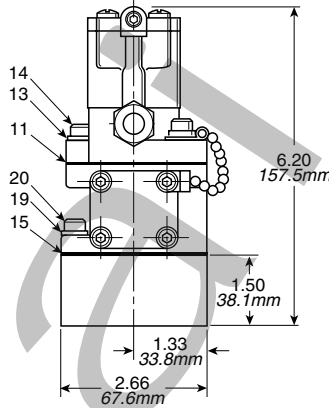
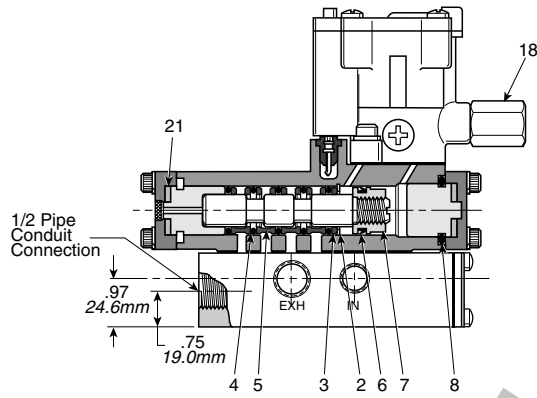
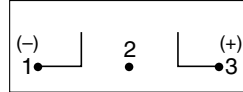

Parts List

Item No.	Part No.	Description
2	K18R311093	Retaining Ring
3	K453 006	Spacer
* 4	—	O-Ring
5	K453 005	Spacer
* 6	—	Seal
7	K232 018	Spool Assy.
* 8	—	Seal
*11	—	Gasket
13	H175 12	Lockwasher
14	H100 60	Cap Screw
*15	—	Gasket
18	K152 003	Override Assy.
19	H175 12	Lockwasher
20	H100 59	Cap Screw
21	K983 001	Shock Pad

* Standard Service Kit: K352 150
 * Special Service Kit: K352 350 (Continuous Duty)

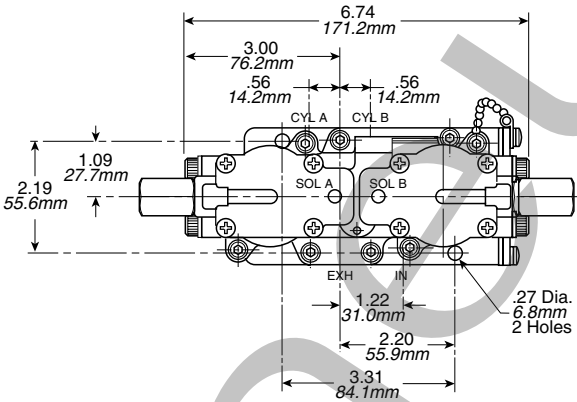

Double Solenoid

See Manifold Section for Manifold Dimensional Data

Wiring Diagram

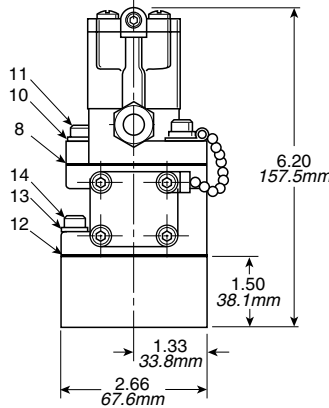
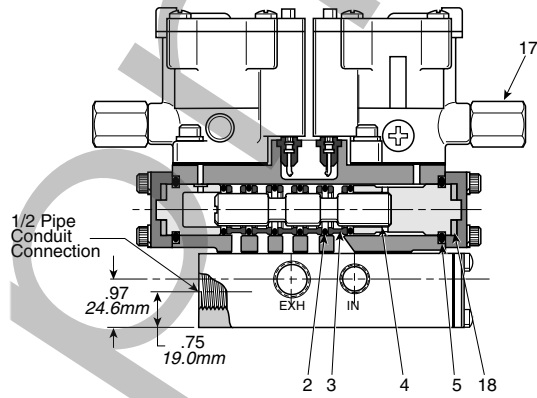
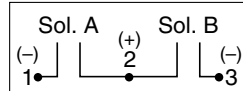

Parts List

Item No.	Part No.	Description
* 2	—	O-Ring
3	K453 005	Spacer
4	K493 005	Spool
* 5	—	Seal
* 8	—	Gasket
10	H175 12	Lockwasher
11	H100 60	Cap Screw
*12	—	Gasket
13	H175 12	Lockwasher
14	H100 59	Cap Screw
17	K152 003	Override Assy.
18	K983 001	Shock Pad

* Standard Service Kit: K352 151
 * Special Service Kit: K352 351 (Continuous Duty)

3/8", 1/2", 3/4 NPT Ports, Nominal Cv = 4.8



Single Solenoid

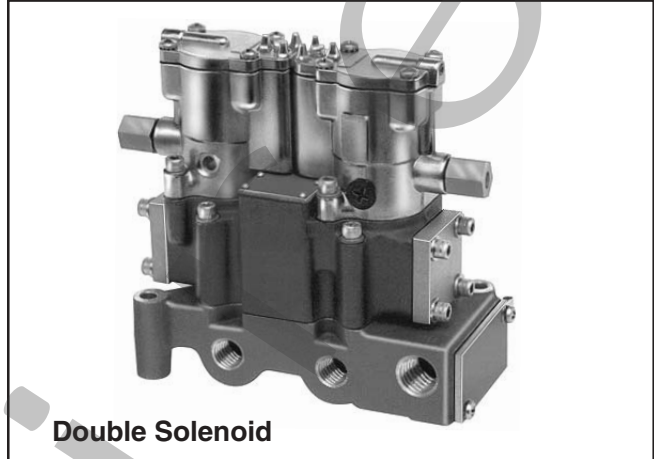

Double Solenoid

Application

These valves may be used to actuate a double acting cylinder. A maintained electrical signal shifts the valve. When this signal is removed the valve returns to its normal condition. For alternate flow path usages, such as dual pressure service, see *Optional Functions* page.

Mounting

These valves are designed for subbase or modular manifold mountings. Electrical connection from valve to base is automatic. Air & electrical connections remain undisturbed if valve is removed. Order from chart below.

Operation: Pressure Service

De-energized (normal condition) – Pressure at Port P is connected to “Cylinder” Port A. “Cylinder” Port B is connected to “Exhaust” Port EB.

Energized (maintained signal applied) – Pressure at Port P is connected to “Cylinder” Port B, “Cylinder” Port A is connected to “Exhaust” Port EA.

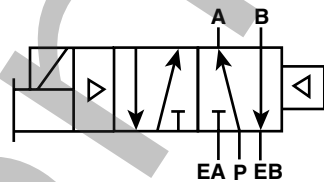

Application

These valves may be used to actuate double acting cylinders. A “momentary” electrical signal (exceeding .03 seconds) applied to one of the solenoids shifts the valve. It will remain in this position until a “momentary” signal is applied to the other solenoid. For alternative flow path usages, such as dual pressure service, see *Optional Functions* page.

Mounting

These valves are designed for subbase or manifold mountings. Electrical connection from valve to base is automatic. Air & electrical connections remain undisturbed if valve is removed. Axis of main valve spool to be in horizontal plane. Order from chart below.

Operation: Pressure Service

With solenoid “A” having been energized last – Pressure at Port P is connected to “Cylinder” Port A. “Cylinder” Port B is connected to “Exhaust” Port EB.

Energize solenoid “B” (momentary) – Pressure at Port P is connected to “Cylinder” Port B. “Cylinder” Port A is connected to “Exhaust” Port EA.

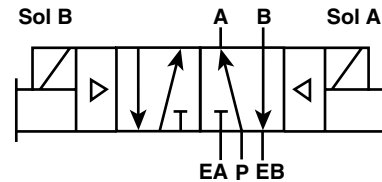

Model Selection

Valve Only		Voltage	Subbase (Side Ports)	Manifold ▲ (End & Bottom Ports)	Port Size (NPT)
Single Solenoid	Double Solenoid				
L675 39 102 53	L655 39 102 53	120V 60Hz 110V 50Hz	K022 090 K022 091	K142 230 K142 231	3/8" 1/2"
L675 33 102 **	L655 33 102 **	Other	K022 101	K142 270	3/4"

See page 3 for variations and (**) voltage codes.

▲ - Manifolds include mounting hardware.

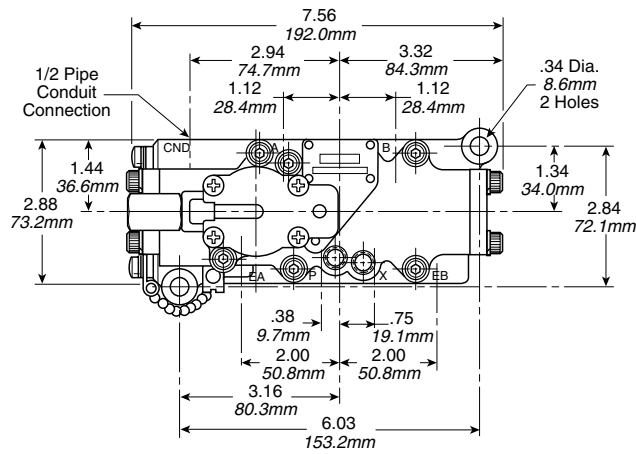

Single Solenoid
See Manifold Section for Manifold Dimensional Data

Wiring Diagram

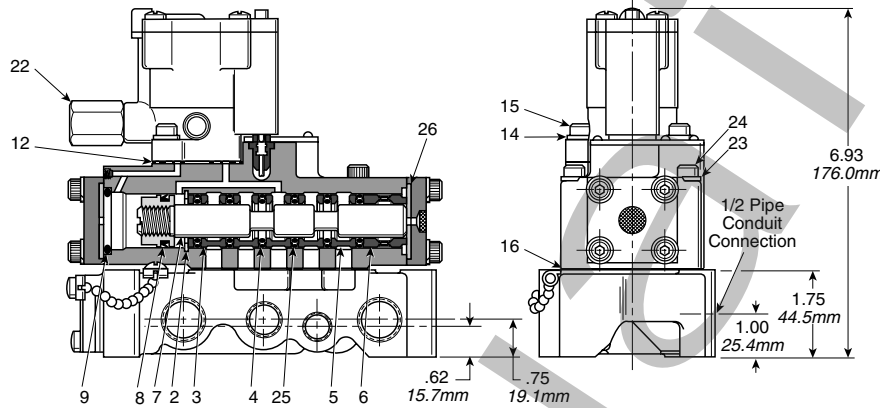
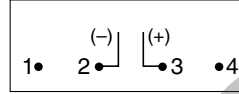

Parts List

Item No.	Part No.	Description
2	H090 71	Retaining Ring
3	K463 015	Spacer
* 4	—	O-Ring (Dynamic)
5	K453 028	Spacer
6	K463 012	End Spacer
7	K232 020	Spool Assy.
* 8	—	Seal
* 9	—	Seal
*12	—	Gasket
14	H175 12	Lockwasher
15	H100 60	Cap Screw
*16	—	Gasket
22	K152 003	Override Assy.
23	H175 12	Lockwasher
24	H100 69	Cap Screw
*25	—	O-Ring (Static)
26	K983 002	Shock Pad

* Standard Service Kit: K352 124

* Special Service Kit: K352 125 (Continuous Duty)

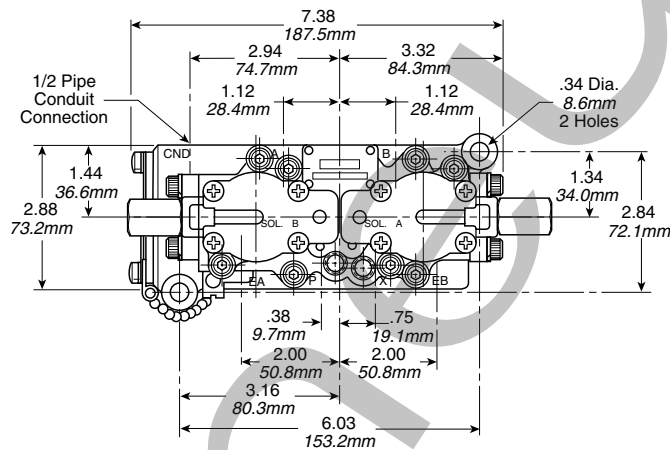

Double Solenoid
See Manifold Section for Manifold Dimensional Data

Wiring Diagram

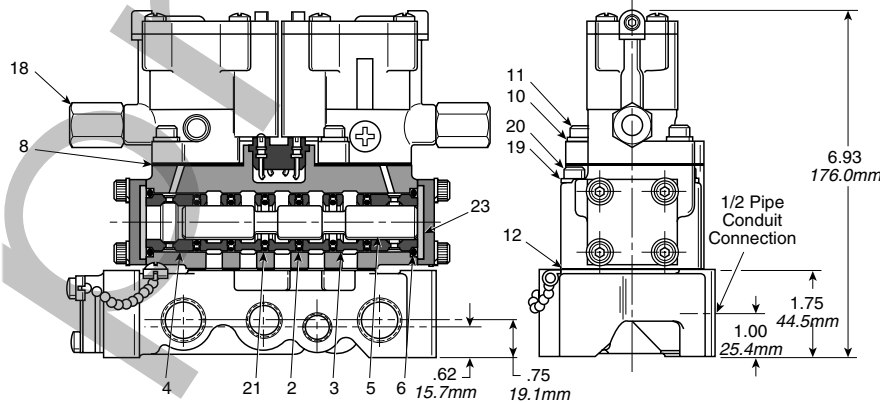
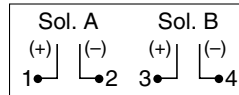

Parts List

Item No.	Part No.	Description
* 2	—	O-Ring (Dynamic)
3	K453 028	Spacer
4	K463 012	End Spacer
5	K343 094	Spool
* 6	—	Seal
* 8	—	Gasket
10	H175 12	Lockwasher
11	H100 60	Cap Screw
*12	—	Gasket
18	K152 003	Override Assy.
19	H175 12	Lockwasher
20	H100 69	Cap Screw
*21	—	O-Ring (Static)
23	K983 002	Shock Pad

* Standard Service Kit: K352 126

* Special Service Kit: K352 127 (Continuous Duty)

1/2" & 3/4" NPT Ports, Nominal Cv = 5.2

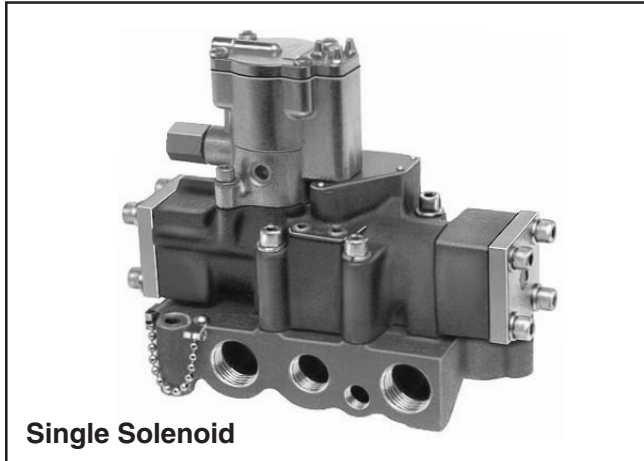

Single Solenoid

Application

These valves may be used to actuate a double acting cylinder. A maintained electrical signal shifts the valve. When this signal is removed the valve returns to its normal condition. For alternate flow path usages, such as dual pressure service, see *Optional Functions* page.

Mounting

These valves are designed for subbase or modular manifold mountings. Electrical connection from valve to base is automatic. Air & electrical connections remain undisturbed if valve is removed. Order from chart below.

Operation: Pressure Service

De-energized (normal condition) – Pressure at Port P is connected to “Cylinder” Port A. “Cylinder” Port B is connected to “Exhaust” Port EB.

Energized (maintained signal applied) – Pressure at Port P is connected to “Cylinder” Port B, “Cylinder” Port A is connected to “Exhaust” Port EA.

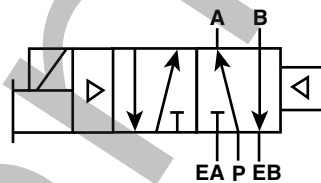

Double Solenoid

Application

These valves may be used to actuate double acting cylinders. A “momentary” electrical signal (exceeding .03 seconds) applied to one of the solenoids shifts the valve. It will remain in this position until a “momentary” signal is applied to the other solenoid. For alternative flow path usages, such as dual pressure service, see *Optional Functions* page.

Mounting

These valves are designed for subbase or manifold mountings. Electrical connection from valve to base is automatic. Air & electrical connections remain undisturbed if valve is removed. Axis of main valve spool to be in horizontal plane. Order from chart below.

Operation: Pressure Service

With solenoid “A” having been energized last – Pressure at Port P is connected to “Cylinder” Port A. “Cylinder” Port B is connected to “Exhaust” Port EB.

Energize solenoid “B” (momentary) – Pressure at Port P is connected to “Cylinder” Port B. “Cylinder” Port A is connected to “Exhaust” Port EA.

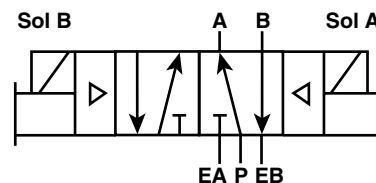

Model Selection

Note: Shaded units are no longer available.

Valve Only		Voltage	Subbase (Side Ports)	Manifold ▲ (End & Bottom Ports)	Port Size (NPT)
Single Solenoid	Double Solenoid				
L545 59 102 53	L515 59 102 53	120V 60Hz 110V 50Hz	K022 092	K142 233	1/2"
L545 53 102 **	L515 53 102 **	Other	K022 093	K142 234	3/4"

See page 4 for variations and (**) voltage codes.

▲ - Manifolds include mounting hardware.

Dimensional Data & Service Kits

L545 & L515, 1/2" Basic Valve

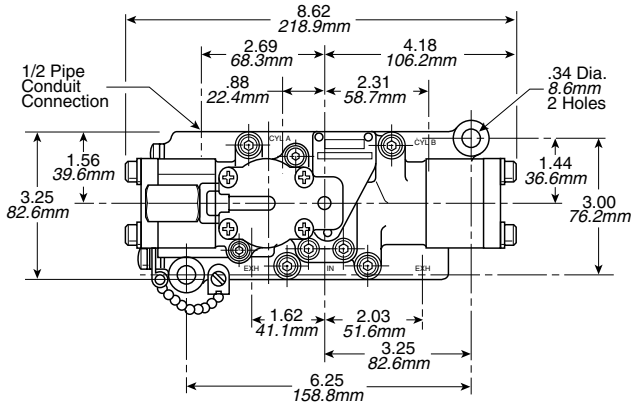

Single Solenoid
See Manifold Section for Manifold Dimensional Data

Wiring Diagram

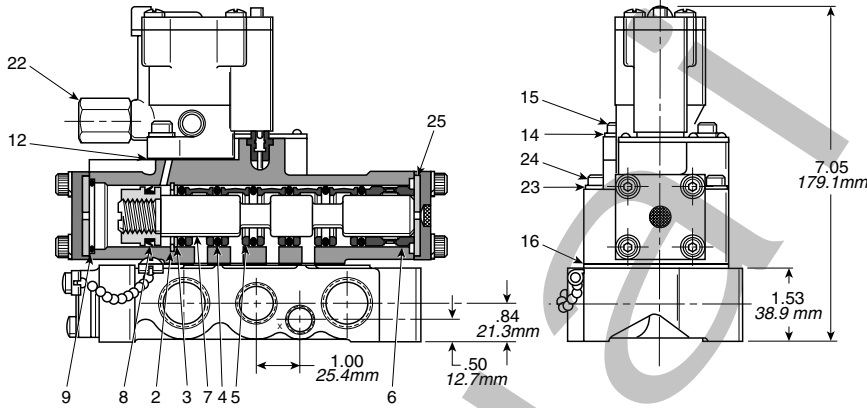
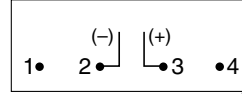

Parts List

Item No.	Part No.	Description
2	K18R311137	Retaining Ring
3	K553 011	Washer
* 4	—	O-Ring
5	K453 008	Spacer
6	K463 001	End Spacer
7	K232 017	Spool Assy.
* 8	—	Seal
* 9	—	Seal
*12	—	Gasket
14	H175 12	Lockwasher
15	H100 60	Cap Screw
*16	—	Gasket
22	K152 003	Override Assy.
23	H175 16	Washer
24	H100 25	Cap Screw
25	K983 003	Shock Pad

* Standard Service Kit: K352 152
* Special Service Kit: K352 352 (Continuous Duty)

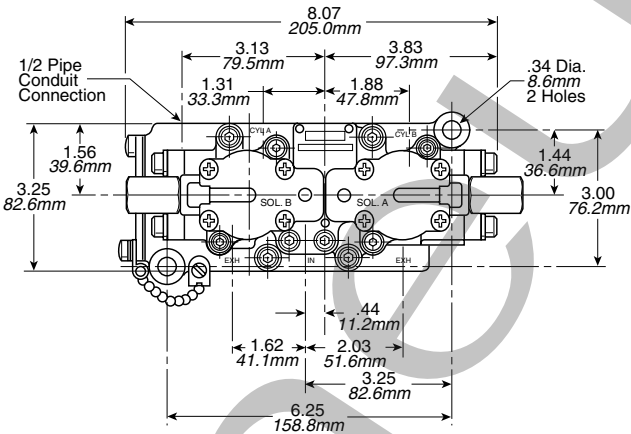

Double Solenoid
See Manifold Section for Manifold Dimensional Data

Wiring Diagram

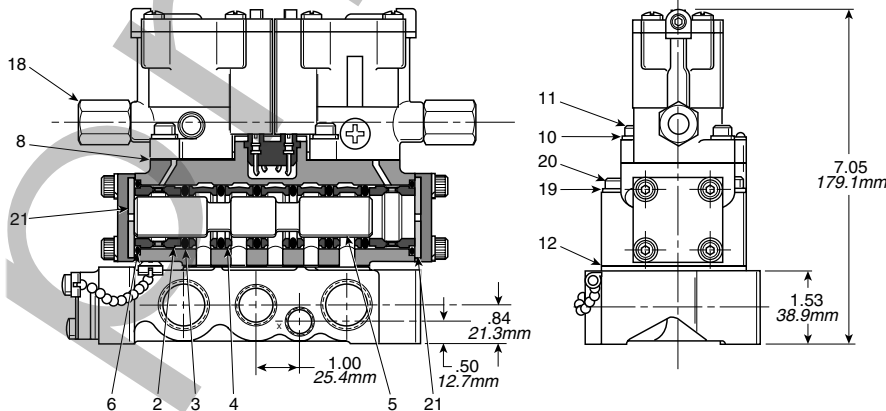
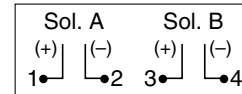

Parts List

Item No.	Part No.	Description
2	K463 001	End Spacer
* 3	—	O-Ring
4	K453 008	Spacer
5	K343 046	Spool
* 6	—	Seal
* 8	—	Gasket
10	H175 12	Lockwasher
11	H100 60	Cap Screw
*12	—	Gasket
18	K152 003	Override Assy.
19	H175 16	Washer
20	H101 25	Cap Screw
21	K983 003	Shock Pad

* Standard Service Kit: K352 153
* Special Service Kit: K352 353 (Continuous Duty)

1/2" & 3/4" NPT Ports, Nominal Cv = 4.8

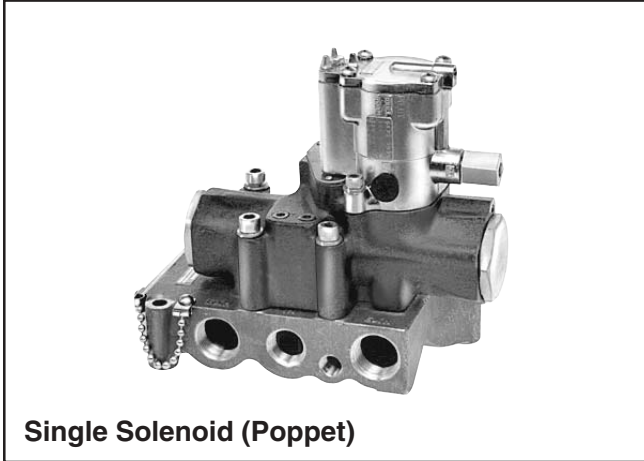

Single Solenoid (Poppet)

Application

These valves may be used to actuate a double acting cylinder. A maintained electrical signal shifts the valve. When this signal is removed the valve returns to its normal condition. For alternate flow path usages, such as dual pressure service, see *Optional Functions* page.

Mounting

These valves are designed for subbase or modular manifold mountings. Electrical connection from valve to base is automatic. Air & electrical connections remain undisturbed if valve is removed. Order from chart below.

Operation: Pressure Service

De-energized (normal condition) – Pressure at Port P is connected to “Cylinder” Port A. “Cylinder” Port B is connected to “Exhaust” Port EB.

Energized (maintained signal applied) – Pressure at Port P is connected to “Cylinder” Port B, “Cylinder” Port A is connected to “Exhaust” Port EA.

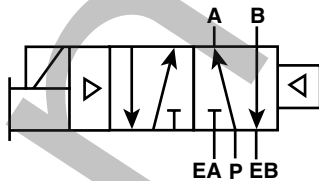

Model Selection

Note: Shaded units are no longer available.

Valve Only	Voltage	Subbase (Side Ports)	Manifold ▲ (End & Bottom Ports)	Port Size (NPT)
Single Solenoid				
L385 49 102 53	120V 60Hz 110V 50Hz	K022 092	K142 233	1/2"
L385 43 102 **	Other	K022 093	K142 234	3/4"

See page 4 for variations and (**) voltage codes.

▲ - Manifolds include mounting hardware.

Dimensional Data & Service Kits

L385, 1/2" Basic Valve

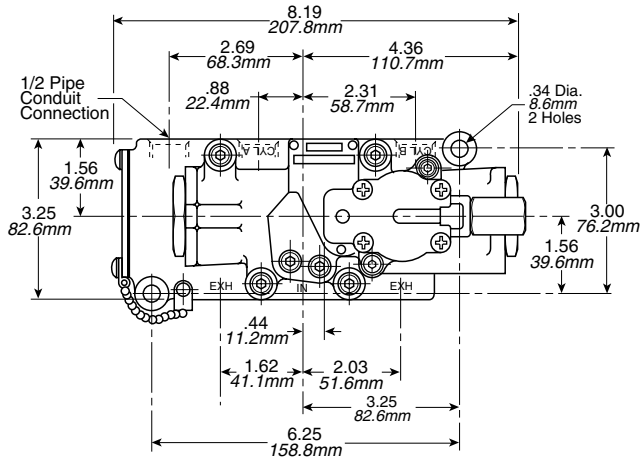

Wiring Diagram

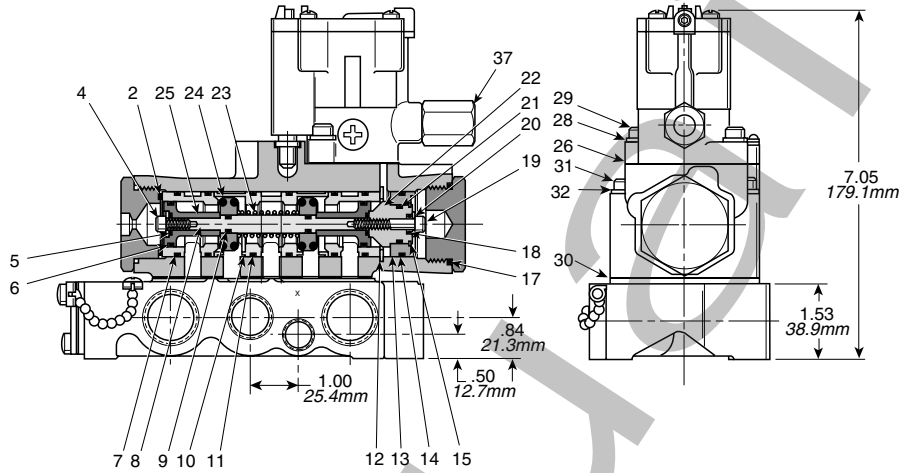
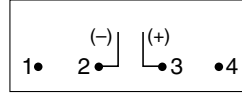

Parts List

Item No.	Part No.	Description
* 2	—	Seal
4	H100 37	Cap Screw
* 5	—	O-Ring
* 6	—	O-Ring
7	K403 006	Spacer (Outer)
8	K493 018	Stem
* 9	—	O-Ring
10	K403 005	Spacer (Center)
*11	—	O-Ring
12	K18R311137	Retaining Ring
13	K313 039	Piston (Outer)
*14	—	O-Ring
15	H089 52	Retaining Ring
*17	—	O-Ring
*18	—	O-Ring
19	H194 32	Cap Screw
20	H178 48	Washer
*21	—	O-Ring
22	K313 038	Piston (Inner)
23	K473 032	Spring
24	K242 002	Poppet Assy.
25	K313 037	Piston
*26	—	Gasket
28	H175 12	Lockwasher
29	H100 60	Cap Screw
*30	—	Gasket
31	H100 69	Cap Screw
32	H175 12	Lockwasher
37	K152 003	Override

* Standard Service Kit: K352 088

* Special Service Kit: K352 089
(Continuous Duty)

See page 34 for Manifold
Dimensional Data

3/4", 1" & 1-1/4" NPT Ports, Nominal Cv = 11.3

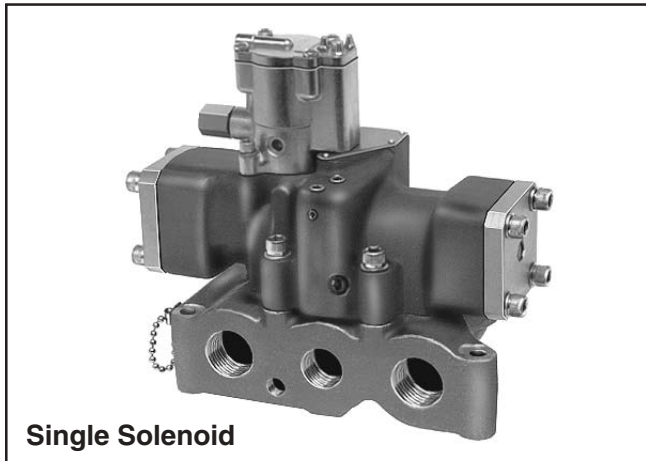

Single Solenoid

Application

These valves may be used to actuate a double acting cylinder. A maintained electrical signal shifts the valve. When this signal is removed the valve returns to its normal condition. For alternate flow path usages, such as dual pressure service, see *Optional Functions* page.

Mounting

These valves are designed for subbase or modular manifold mountings. Electrical connection from valve to base is automatic. Air & electrical connections remain undisturbed if valve is removed. Order from chart below.

Operation: Pressure Service

De-energized (normal condition) – Pressure at Port P is connected to “Cylinder” Port A. “Cylinder” Port B is connected to “Exhaust” Port EB.

Energized (maintained signal applied) – Pressure at Port P is connected to “Cylinder” Port B, “Cylinder” Port A is connected to “Exhaust” Port EA.

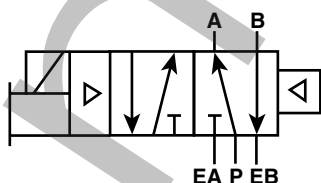

Double Solenoid

Application

These valves may be used to actuate double acting cylinders. A “momentary” electrical signal (exceeding .03 seconds) applied to one of the solenoids shifts the valve. It will remain in this position until a “momentary” signal is applied to the other solenoid. For alternative flow path usages, such as dual pressure service, see *Optional Functions* page.

Mounting

These valves are designed for subbase or manifold mountings. Electrical connection from valve to base is automatic. Air & electrical connections remain undisturbed if valve is removed. Axis of main valve spool to be in horizontal plane. Order from chart below.

Operation: Pressure Service

With solenoid “A” having been energized last – Pressure at Port P is connected to “Cylinder” Port A. “Cylinder” Port B is connected to “Exhaust” Port EB.

Energize solenoid “B” (momentary) – Pressure at Port P is connected to “Cylinder” Port B. “Cylinder” Port A is connected to “Exhaust” Port EA.

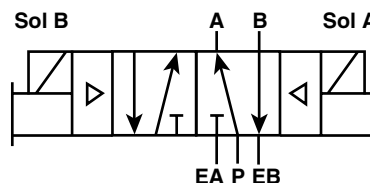

Model Selection

Note: Shaded units are no longer available.

Valve Only		Voltage	Subbase (Side Ports)	Manifold ▲ (End & Bottom Ports)	Port Size (NPT)	Port Adapter (Manifolds)
Single Solenoid	Double Solenoid					
L675 89 102 53	L655 89 102 53	120V 60Hz 110V 50Hz	K022 094	K142 235	3/4"	K122 016 Kit Includes Both Ends
L675 83 102 **	L655 83 102 **	Other	K022 095	K142 236	1"	
			K022 096	K142 237	1-1/4"	

See page 3 for variations and (**) voltage codes.

▲ - Manifolds include mounting hardware, except for port adapters. See chart, order separately.

Dimensional Data & Service Kits

L675 & L655, 1" Basic Valve

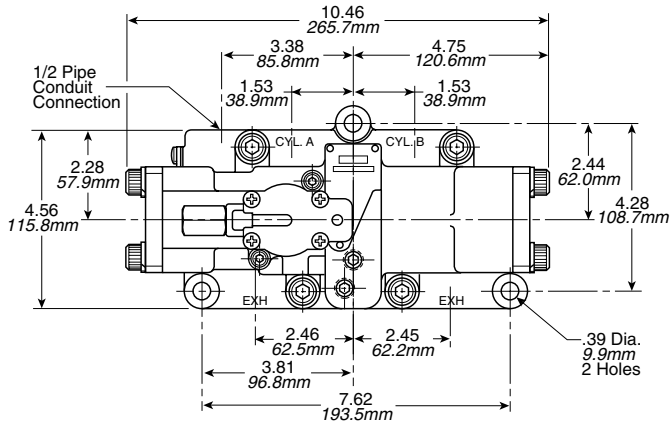

Single Solenoid
 See Manifold Section for Manifold Dimensional Data

Wiring Diagram

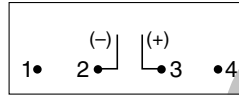

Parts List

Item No.	Part No.	Description
2	H090 09	Retaining Ring
3	K553 009	Spacer
* 4	—	O-Ring (Dynamic)
* 5	—	O-Ring (Static)
6	K453 009	Spacer
7	K463 005	End Spacer
8	K232 014	Spool Assy.
* 9	—	O-Ring
*10	—	Seal
*13	—	Gasket
15	H175 12	Lockwasher
16	H100 60	Cap Screw
*17	—	Gasket
23	K152 003	Override Assy.
24	H175 20	Lockwasher
25	H101 48	Cap Screw
26	K983 004	Shock Pad

* Standard Service Kit: K352 128

* Special Service Kit: K352 129 (Continuous Duty)

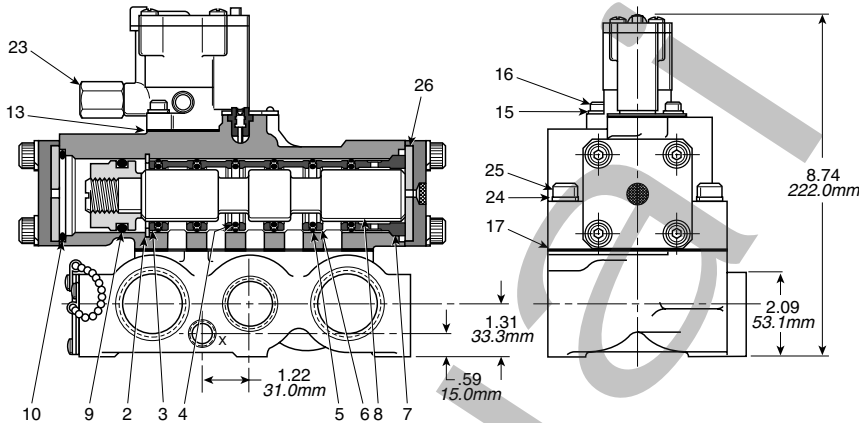

Double Solenoid
 See Manifold Section for Manifold Dimensional Data

Wiring Diagram

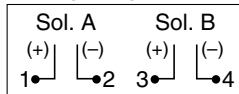

Parts List

Item No.	Part No.	Description
2	K463 005	End Spacer
* 3	—	O-Ring (Dynamic)
* 4	—	O-Ring (Static)
5	K453 009	Spacer
6	K343 061	Spool
* 7	—	Seal
* 9	—	Gasket
11	H175 12	Lockwasher
12	H100 60	Cap Screw
*13	—	Gasket
19	K152 003	Override Assy.
20	H175 20	Lockwasher
21	H101 48	Cap Screw
22	K983 004	Shock Pad

* Standard Service Kit: K352 130

* Special Service Kit: K352 131 (Continuous Duty)

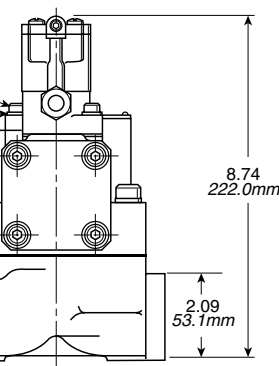
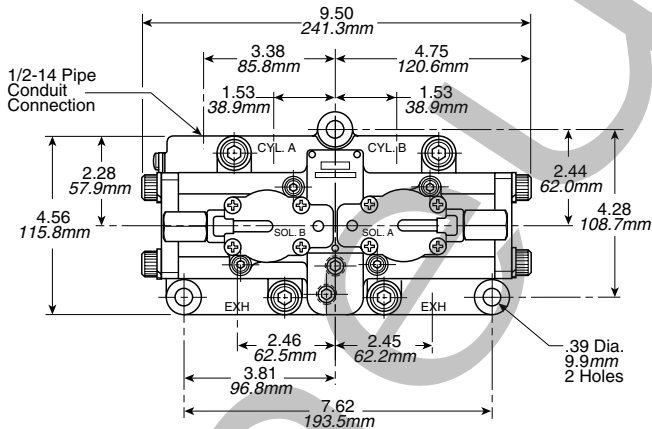

1/4" NPT Ports, Nominal Cv = 1.4

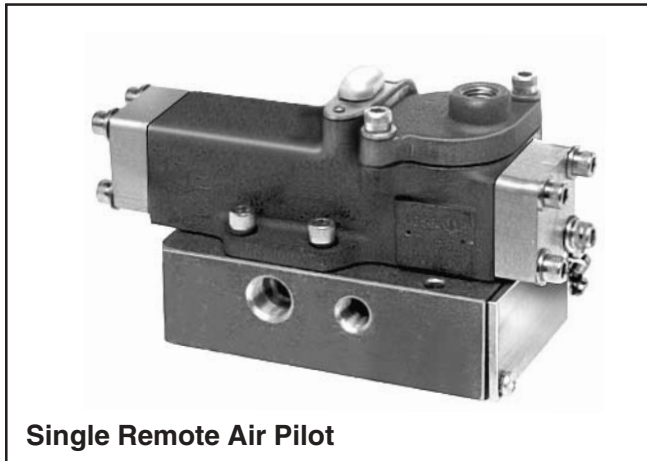

Single Remote Air Pilot

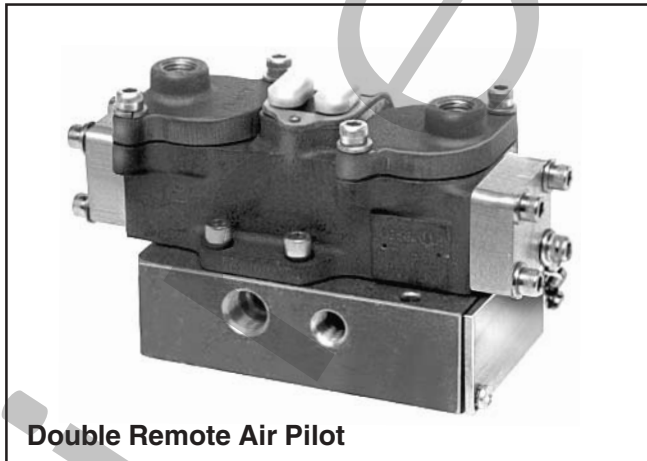

Double Remote Air Pilot

Application

These valves may be used to activate double acting cylinders. A maintained pressure signal to the pilot cap activates the valve. When this signal is removed, the valve shifts. For alternate flow path usages, see *Optional Functions* page.

Mounting

These valves are designed for subbase or modular manifold mountings. Order from chart below.

Operation: Pressure Service

Pressure to pilot cap – Port P is connected to “Cylinder” Port A. “Cylinder” Port B is connected to “Exhaust” Port E.
When pressure to pilot is removed – Pressure at port P is connected to “Cylinder” Port B. “Cylinder” Port A is connected to “Exhaust” Port E.

Application

These valves may be used to activate double acting cylinders. A momentary pressure signal applied alternately to each of the pilot caps shifts the valve. For alternate flow path usages, see *Optional Functions* page.

Mounting

These valves are designed for subbase or modular manifold mountings. This design valve spool to be in horizontal plane. Order from chart below.

Operation: Pressure Service

Pilot “A” pressurized last – Pressure at Port P is connected to “Cylinder” Port B. “Cylinder” Port A is connected to “Exhaust” Port E.
Pilot “B” pressurized last – Pressure at Port P is connected to “Cylinder” Port A. “Cylinder” Port B is connected to “Exhaust” Port E.

DISCONTINUED

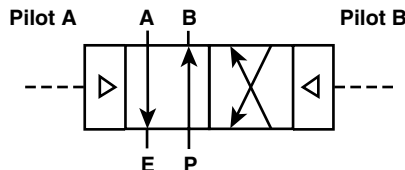
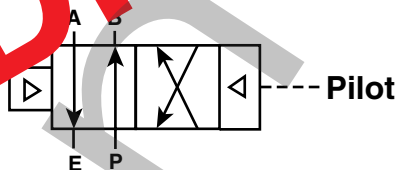

Model Selection

Note: Shaded units are no longer available.

Valve Only		Subbase (Side Ports)	Manifold (End & Bottom Ports) ▲		Port Size (NPT)
Single Solenoid	Double Solenoid		2 Station	3 Station	
L444 21 102	L414 21 102	K022 097	K142 077	K142 076	1/4"

▲ - Manifolds include mounting hardware.

Dimensional Data & Service Kits

L444 & L414, 1/4" Basic Valve

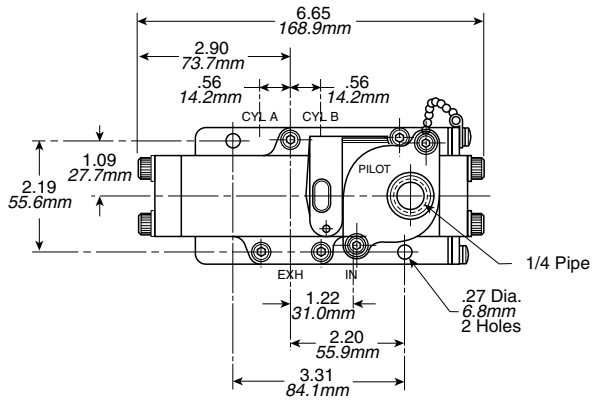

Single Remote

See Manifold Section for Manifold Dimensional Data

Parts List

Item No.	Part No.	Description
2	K18R311093	Retaining Ring
3	K453 006	Spacer
* 4	—	O-Ring
5	K453 005	Spacer
* 6	—	Seal
7	K232 018	Spool Assy.
* 8	—	Seal
*11	—	Gasket
13	H175 12	Lockwasher
14	H100 60	Cap Screw
*15	—	Gasket
16	K323 027	Remote Cap
17	K333 013	Plug Cap
19	H175 12	Lockwasher
20	H100 59	Cap Screw
21	K983 001	Shock Pad

* Standard Service Kit: K352 363

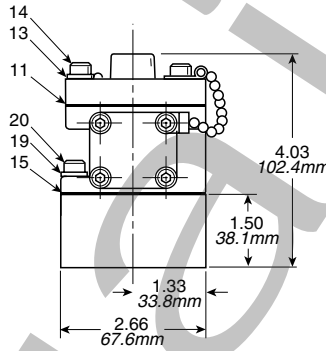
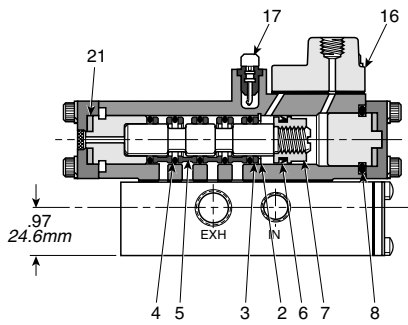

Double Remote

See Manifold Section for Manifold Dimensional Data

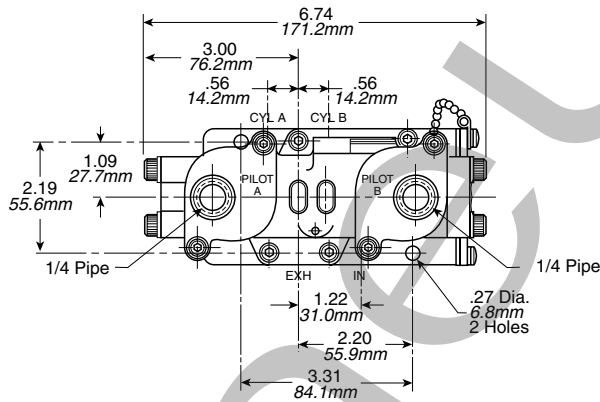

Parts List

Item No.	Part No.	Description
* 2	—	O-Ring
3	K453 005	Spacer
4	K493 005	Spool
* 5	—	Seal
7	K333 013	Plug Cap
* 8	—	Gasket
9	K323 027	Remote Cap
10	H175 12	Lockwasher
11	H100 60	Cap Screw
*12	—	Gasket
13	H175 12	Lockwasher
14	H100 59	Cap Screw
18	K983 001	Shock Pad

* Standard Service Kit: K352 357

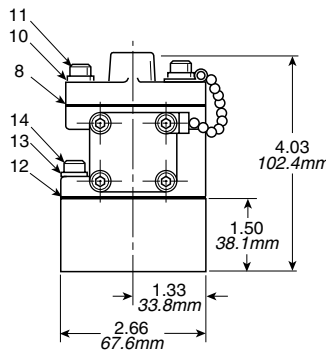
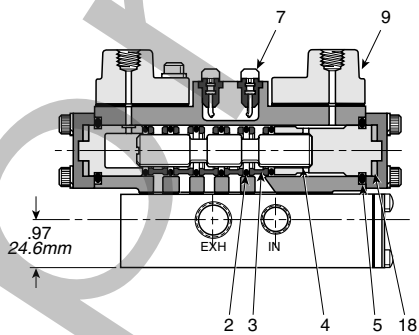

3/8" Thru 3/4" NPT Ports, Nominal Cv = 4.8



Single Remote Air Pilot

Application

These valves may be used to activate double acting cylinders. A maintained pressure signal to the pilot cap activates the valve. When this signal is removed, the valve shifts. For alternate flow path usages, see *Optional Functions* page.

Mounting

These valves are designed for subbase or modular manifold mountings. Order from chart below.

Operation: Pressure Service

Pressure to pilot cap – Port P is connected to “Cylinder” Port A. “Cylinder” Port B is connected to “Exhaust” Port EB.

When pressure to pilot is removed – Pressure at Port P is connected to “Cylinder” Port B. “Cylinder” Port A is connected to “Exhaust” Port EA.

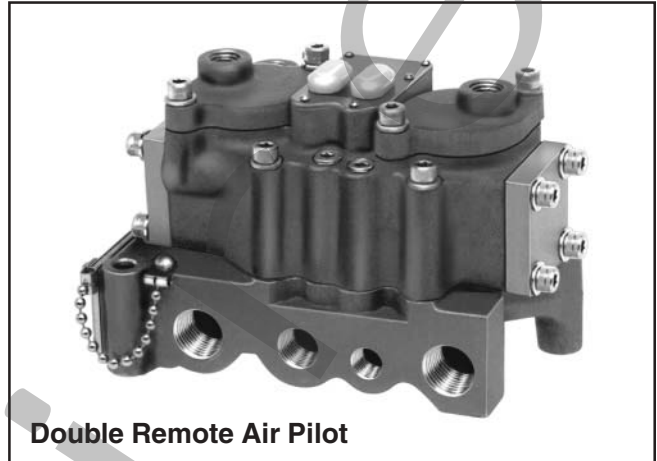
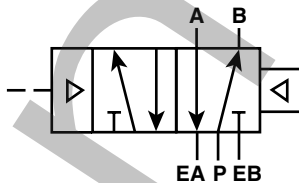

Double Remote Air Pilot

Application

These valves may be used to activate double acting cylinders. A momentary pressure signal applied alternately to each of the pilot caps shifts the valve. For alternate flow path usages, see *Optional Functions* page.

Mounting

These valves are designed for subbase or modular manifold mountings. Axis of main valve spool to be in horizontal plane. Order from chart below.

Operation: Pressure Service

Pilot “A” pressurized last – Pressure at Port P is connected to “Cylinder” Port B. “Cylinder” Port A is connected to “Exhaust” Port EA.

Pilot “B” pressurized last – Pressure at Port P is connected to “Cylinder” Port A. “Cylinder” Port B is connected to “Exhaust” Port EB.

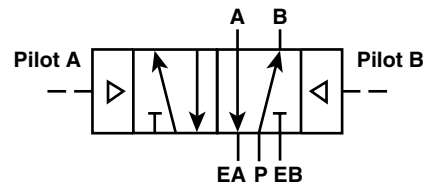

Model Selection

Valve Only		Subbase (Side Ports)	Manifold ▲ (End & Bottom Ports)	Port Size (NPT)
Single Remote	Double Remote			
L674 31 102	L654 31 102	K022 090	K142 230	3/8"
		K022 091	K142 231	1/2"
		K022 101	K142 270	3/4"

▲ - Manifolds include mounting hardware.

Dimensional Data & Service Kits

L674 & L654, 3/8" Basic Valve

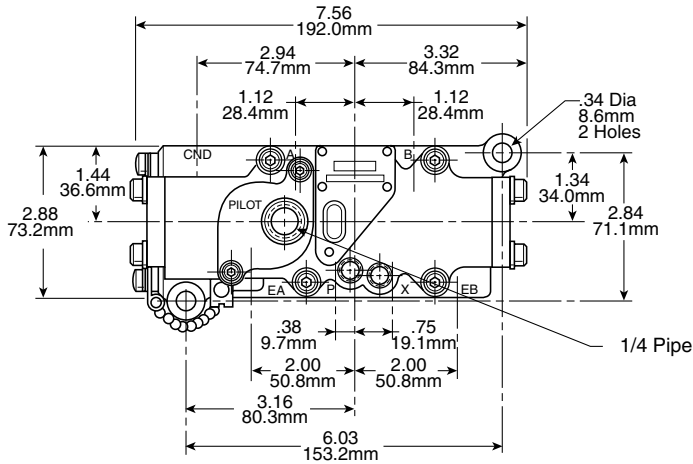

Single Remote
See Manifold Section for Manifold Dimensional Data

Parts List

Item No.	Part No.	Description
2	H090 71	Retaining Ring
3	K463 015	Spacer
* 4	—	O-Ring (Dynamic)
5	K453 028	Spacer
6	K463 012	End Spacer
7	K232 020	Spool Assy.
* 8	—	Seal
* 9	—	Seal
11	K333 013	Plug Cap
*12	—	Gasket
13	K323 027	Remote Cap
14	H175 12	Lockwasher
15	H100 60	Cap Screw
*16	—	Gasket
23	H175 12	Lockwasher
24	H100 69	Cap Screw
*25	—	O-Ring (Static)
26	K983 002	Shock Pad

* Standard Service Kit: K352 362

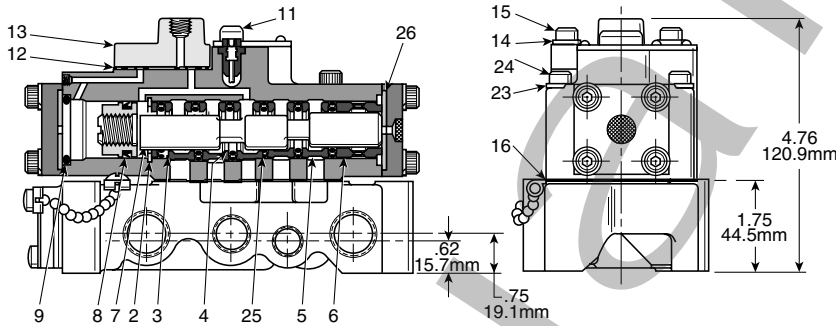

Double Remote
See Manifold Section for Manifold Dimensional Data

Parts List

Item No.	Part No.	Description
* 2	—	O-Ring (Dynamic)
3	K453 028	Spacer
4	K463 012	End Spacer
5	K343 094	Spool
* 6	—	Seal
* 8	—	Gasket
10	H175 12	Lockwasher
11	H100 60	Cap Screw
*12	—	Gasket
13	K323 027	Remote Cap
14	K333 013	Plug Cap
19	H175 12	Lockwasher
20	H100 69	Cap Screw
*21	—	O-Ring (Static)
23	K983 002	Shock Pad

* Standard Service Kit: K352 355

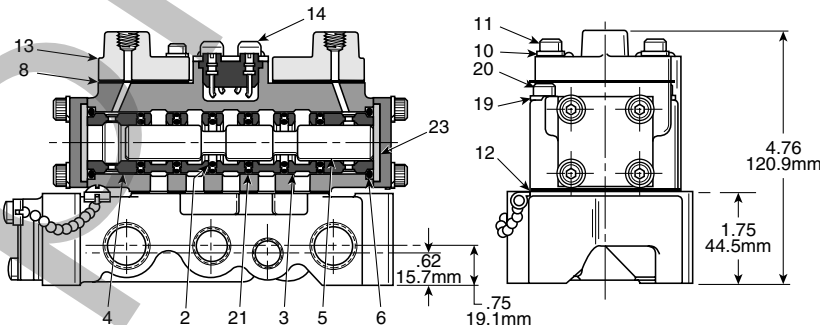
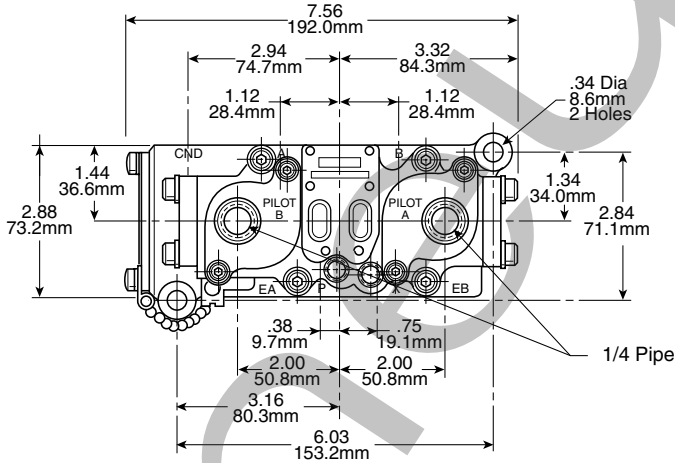

1/2" & 3/4" NPT Ports, Nominal Cv = 5.2

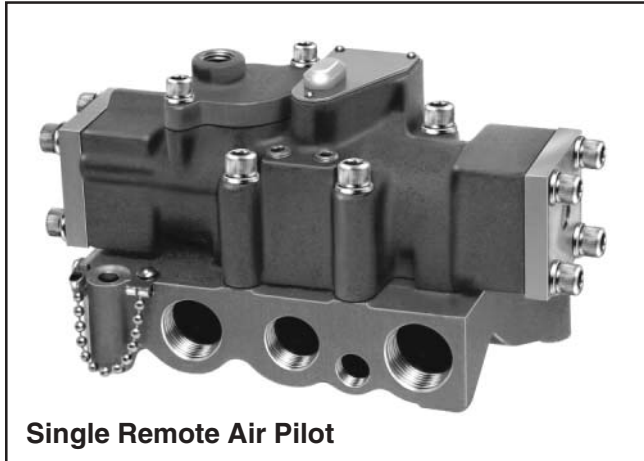

Single Remote Air Pilot

Application

These valves may be used to activate double acting cylinders. A maintained pressure signal to the pilot cap activates the valve. When this signal is removed, the valve shifts. For alternate flow path usages, see *Optional Functions* page.

Mounting

These valves are designed for subbase or modular manifold mountings. Order from chart below.

Operation: Pressure Service

Pressure to pilot cap – Port P is connected to “Cylinder” Port A. “Cylinder” Port B is connected to “Exhaust” Port EB.

When pressure to pilot is removed – Pressure at Port P is connected to “Cylinder” Port B. “Cylinder” Port A is connected to “Exhaust” Port EA.

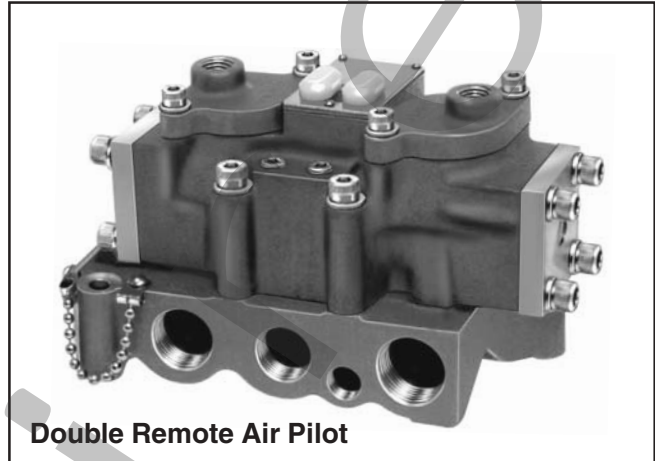
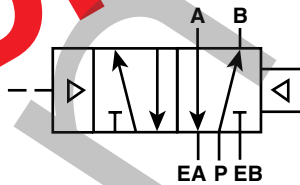

Double Remote Air Pilot

Application

These valves may be used to activate double acting cylinders. A momentary pressure signal applied alternately to each of the pilot caps shifts the valve. For alternate flow path usages, see *Optional Functions* page.

Mounting

These valves are designed for subbase or modular manifold mountings. Position of main valve spool to be in horizontal plane. Order from chart below.

Operation: Pressure Service

Pilot “A” pressurized last – Pressure at Port P is connected to “Cylinder” Port B. “Cylinder” Port A is connected to “Exhaust” Port EA.

Pilot “B” pressurized last – Pressure at Port P is connected to “Cylinder” Port A. “Cylinder” Port B is connected to “Exhaust” Port EB.

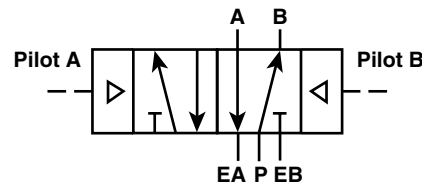

Model Selection

Note: Shaded units are no longer available.

Valve Only		Subbase (Side Ports)	Manifold ▲ (End & Bottom Ports)	Port Size (NPT)
Single Remote	Double Remote			
L544 51 102	L514 51 102	K022 092	K142 233	1/2"
		K022 093	K142 234	3/4"

▲ - Manifolds include mounting hardware.

Dimensional Data & Service Kits

L544 & L514, 1/2" Basic Valve

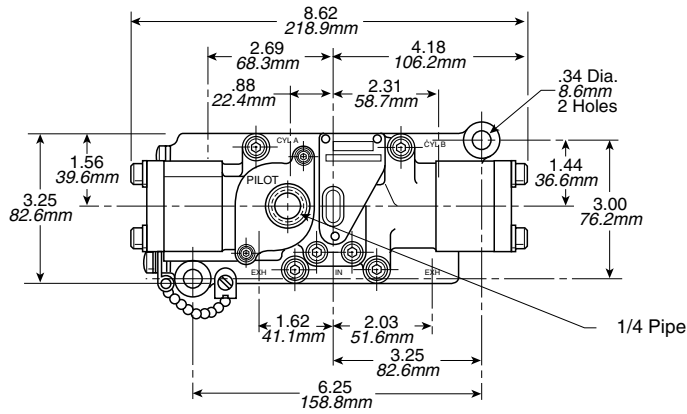

Single Remote

See Manifold Section for Manifold Dimensional Data

Parts List

Item No.	Part No.	Description
2	K18R311137	Retaining Ring
3	K553 011	Spacer
* 4	—	O-Ring
5	K453 008	Spacer
6	K463 001	End Spacer
7	K232 017	Spool Assy.
* 8	—	Seal
*12	—	Gasket
14	H175 12	Lockwasher
15	H100 60	Cap Screw
*16	—	Gasket
17	K323 027	Remote Cap
18	K333 013	Plug Cap
23	H175 16	Lockwasher
24	H101 25	Cap Screw
25	K983 003	Shock Pad

* Standard Service Kit: K352 361

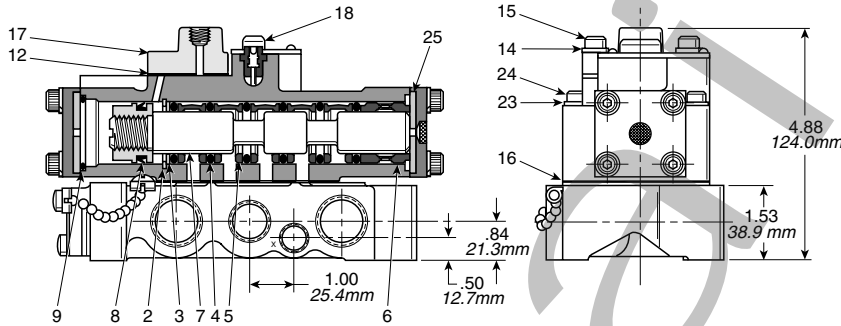

Double Remote

See Manifold Section for Manifold Dimensional Data

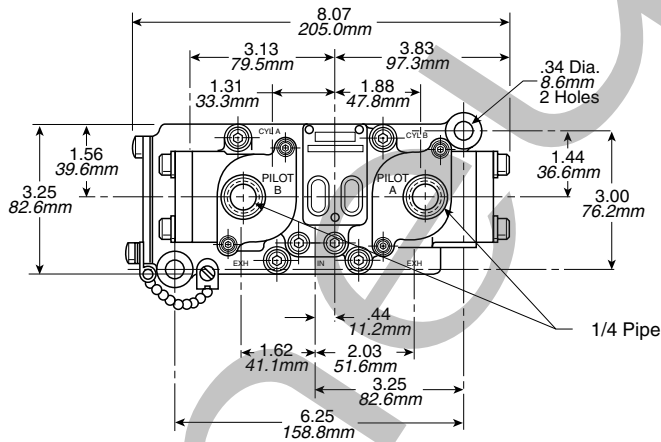

Parts List

Item No.	Part No.	Description
2	K463 001	End Spacer
* 3	—	O-Ring
4	K453 008	Spacer
5	K343 046	Spool
* 6	—	Seal
* 8	—	Gasket
10	H175 12	Lockwasher
11	H100 60	Cap Screw
*12	—	Gasket
13	K323 027	Remote Cap
14	K333 013	Plug Cap
19	H175 16	Lockwasher
20	H101 25	Cap Screw
21	K983 003	Shock Pad

* Standard Service Kit: K352 358

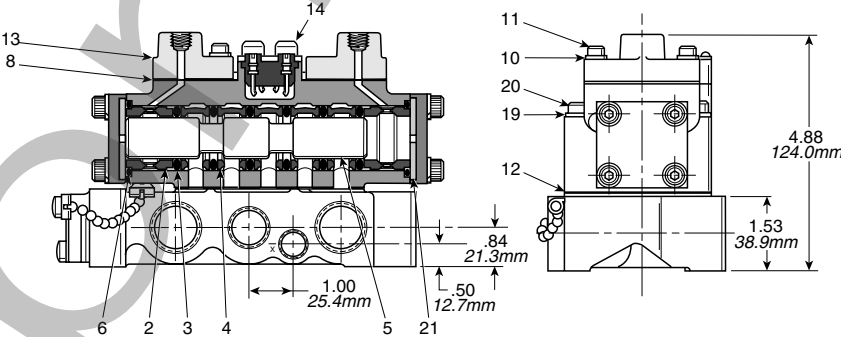

3/4" Thru 1-1/4" NPT Ports, Nominal Cv = 11.3



Single Remote Air Pilot

Application

These valves may be used to activate double acting cylinders. A maintained pressure signal to the pilot cap activates the valve. When this signal is removed, the valve shifts. For alternate flow path usages, see *Optional Functions* page.

Mounting

These valves are designed for subbase or modular manifold mountings. Order from chart below.

Operation: Pressure Service

Pressure to pilot cap – Port P is connected to “Cylinder” Port A. “Cylinder” Port B is connected to “Exhaust” Port EB.

When pressure to pilot is removed – Pressure at Port P is connected to “Cylinder” Port B. “Cylinder” Port A is connected to “Exhaust” Port EA.

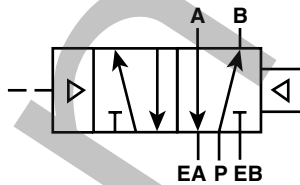

Double Remote Air Pilot

Application

These valves may be used to activate double acting cylinders. A momentary pressure signal applied alternately to each of the pilot caps shifts the valve. For alternate flow path usages, see *Optional Functions* page.

Mounting

These valves are designed for subbase or modular manifold mountings. Axis of main valve spool to be in horizontal plane. Order from chart below.

Operation: Pressure Service

Pilot “A” pressurized last – Pressure at Port P is connected to “Cylinder” Port B. “Cylinder” Port A is connected to “Exhaust” Port EA.

Pilot “B” pressurized last – Pressure at Port P is connected to “Cylinder” Port A. “Cylinder” Port B is connected to “Exhaust” Port EB.

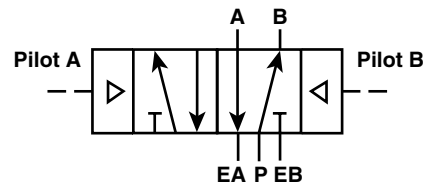

Model Selection

Note: Shaded units are no longer available.

Valve Only		Subbase (Side Ports)	Manifold ▲ (End & Bottom Ports)	Port Size (NPT)	Port Adapter
Single Solenoid	Double Solenoid				
L674 81 102	K654 81 102	K022 094	K142 235	3/4"	K122 016 Kit Includes Both Ends
		K022 095	K142 236	1"	
		K022 096	K142 237	1-1/4"	

▲ - Manifolds include mounting hardware, except for port adapters. See chart, order separately.

Dimensional Data & Service Kits

L674 & L654, 1" Basic Valve

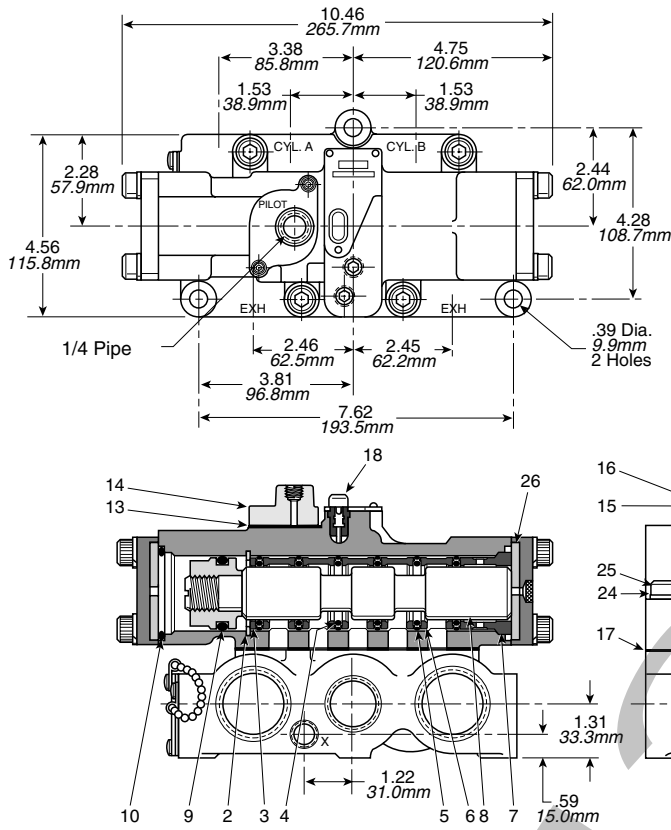

Single Remote
See Manifold Section for Manifold Dimensional Data

Parts List

Item No.	Part No.	Description
2	H090 09	Retaining Ring
3	K553 009	Spacer
* 4	—	O-Ring (Dynamic)
* 5	—	O-Ring (Static)
6	K453 009	Spacer
7	K463 005	Spacer
8	K232 014	Spool Assy.
* 9	—	O-Ring
*10	—	Seal
*13	—	Gasket
14	K323 027	Remote Cap
15	H175 12	Lockwasher
16	H100 60	Cap Screw
*17	—	Gasket
18	K333 013	Plug Cap
24	H175 20	Lockwasher
25	H101 48	Cap Screw
26	K983 004	Shock Pad

* Standard Service Kit: K352 359

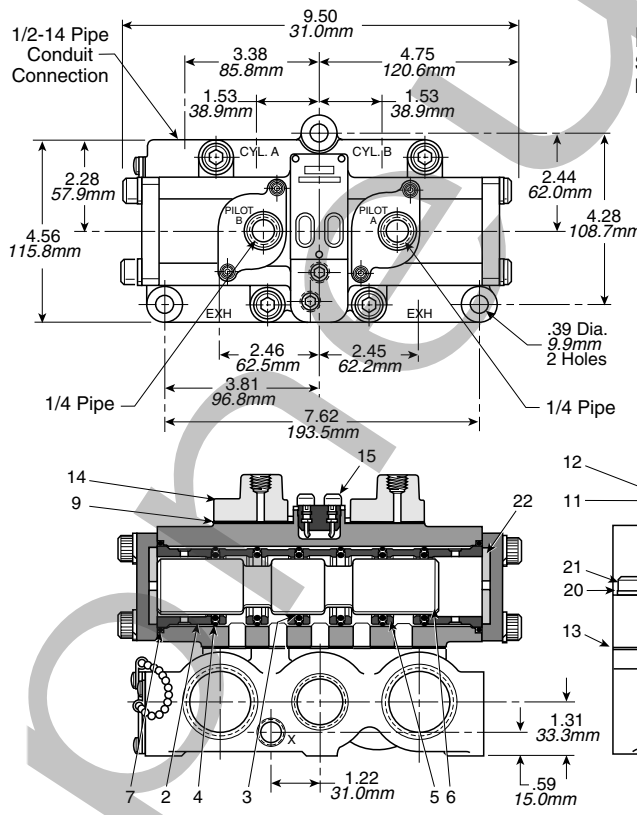

Double Remote
See Manifold Section for Manifold Dimensional Data

Parts List

Item No.	Part No.	Description
2	K463 005	End Spacer
* 3	—	O-Ring (Dynamic)
* 4	—	O-Ring (Static)
5	K453 009	Spacer
6	K343 061	Spool
* 7	—	Seal
* 9	—	Gasket
11	H175 12	Lockwasher
12	H100 60	Cap Screw
*13	—	Gasket
14	K323 027	Remote Cap
15	K333 013	Plug Cap
20	H175 20	Lockwasher
21	H101 48	Cap Screw
22	K983 004	Shock Pad

* Standard Service Kit: K352 360

4-Way, 4-Port, 3-Position & 4-Way, 5-Port, 3-Position - 1/4", 1/2" & 3/4" NPT Ports

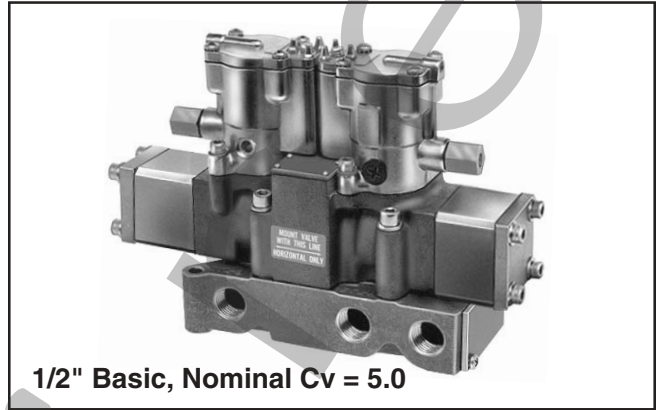
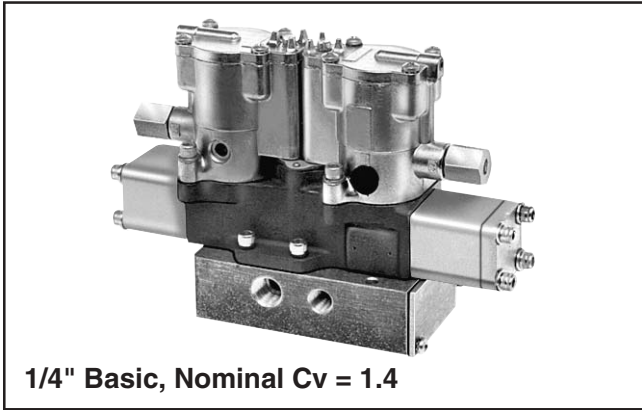

Application

These valves may be used to actuate double acting cylinders, when "inching" or incremental rod movement is desired. A "momentary" (exceeding .03 seconds) or maintained electrical signal applied to one of the solenoids shifts the valve, the valve returns to the "neutral" condition when the electrical signal is removed. Valve may be applied for alternate service. For alternate flow path usages, see *Optional Functions* page.

Mounting

These valves are designed for subbase or modular manifold mountings. Electrical connection from valve to base is automatic. Air & electrical connections remain undisturbed if valve is removed. Order from chart below.

Operation: Pressure Service

Neutral "Class 21"

Both solenoids de-energized (Normal Condition) – All ports blocked.

Neutral "Class 22" (L525 Only)

Both solenoids de-energized (Normal Condition) – "Cylinder" Port A is open to "Exhaust" Port E (EA), "Cylinder" Port B is open to "Exhaust" Port E (EB), "Pressure" Port P is blocked.

Neutral "Class 23"

Both solenoids de-energized (Normal Condition) – "Cylinder" Port A is open to Pressure Port P, "Cylinder" Port B is open to Pressure Port P. Both "Exhaust" Port(s) E (EA and EB) are blocked.

Activated Operation

With solenoid "A" energized – Pressure at Port P flows to "Cylinder" Port A, "Cylinder" Port B is connected to "Exhaust" Port E (EB), regardless of neutral "class".

With solenoid "B" energized – Pressure at Port P flows to "Cylinder" Port B, "Cylinder" Port A is connected to "Exhaust" Port E (EA), regardless of "neutral" configuration.

1/4" Basic

1/2" Basic

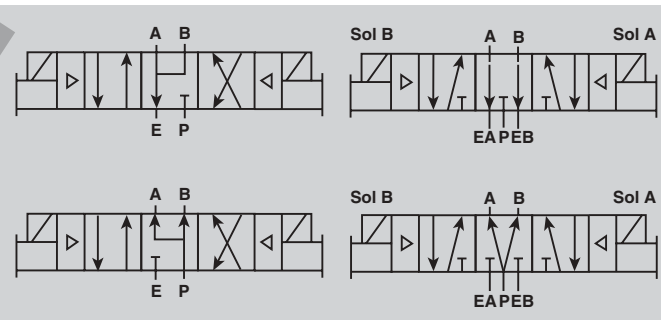
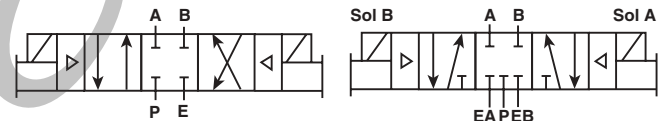

Model Selection (Neutral "Class 21" Shown)

Note: Shaded units are no longer available.

Valve Only	Voltage	Subbase (Side Ports)	Manifold (End & Bottom Ports) ▲			Port Size (NPT)
			2 Station	3 Station	Modular	
L425 29 211 53	120V 60Hz 110V 50Hz	K022 097	K142 077	K142 076	—	1/4"
L425 23 211 **	Other					
L525 59 211 53	120V 60Hz 110V 50Hz	K022 092	—	—	K142 233	1/2"
L525 53 211 **	Other	K022 093	—	—	K142 234	3/4"

See page 4 & 5 for variations in class of neutral configuration and (**) voltage codes.

▲ - Manifolds include mounting hardware.

Dimensional Data & Service Kits

L425 & L525, 1/4" & 1/2" Basic Valve

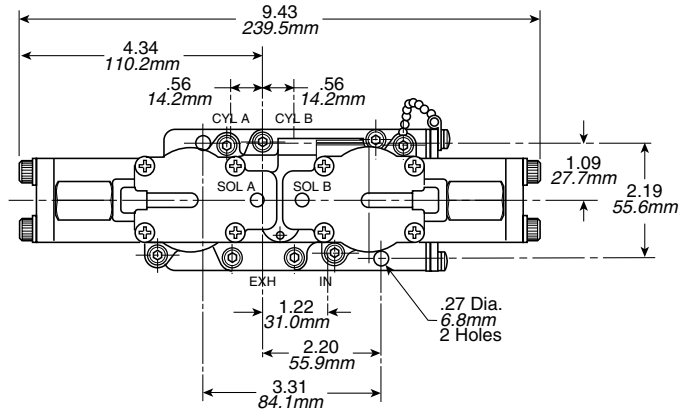

1/4" Basic
See Manifold Section for Manifold Dimensional Data

Wiring Diagram

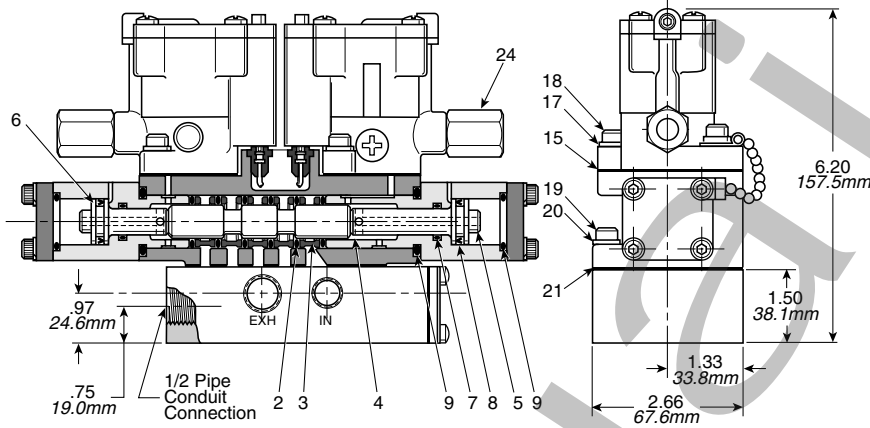
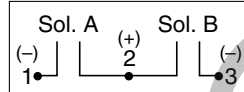

Parts List

Item No.	Part No.	Description
* 2	—	O-Ring
3	K453 005	Spacer
4	K343 020	Spool (All Ports Blocked)
4	K343 073	Spool (Cyl. Ports Open to Exh.)
4	K343 021	Spool (Cyl. Ports Open to Inlet)
5	K313 009	Piston (Long)
6	K313 010	Piston (Short)
* 7	—	Seal
* 8	—	Seal
* 9	—	Seal
*15	—	Gasket
17	H175 12	Lockwasher
18	H100 60	Cap Screw
19	H100 59	Cap Screw
20	H175 12	Lockwasher
*21	—	Gasket
24	K152 003	Override Assy.

* Standard Service Kit: K352 151
* Special Service Kit: K352 351 (Continuous Duty)

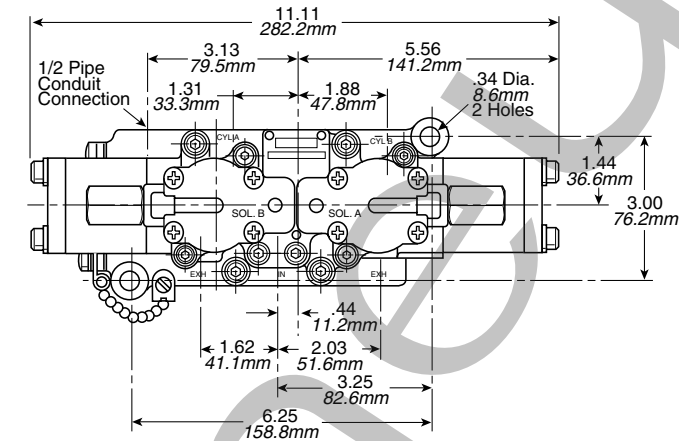

1/2" Basic
See Manifold Section for Manifold Dimensional Data

Wiring Diagram

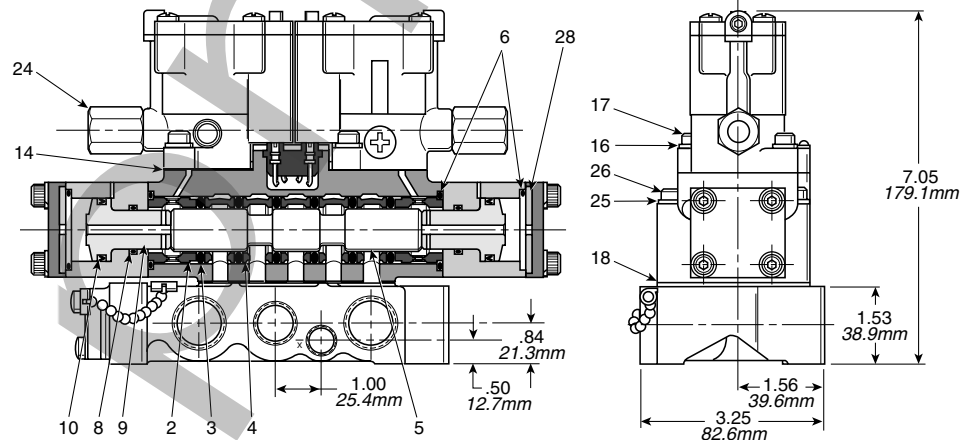
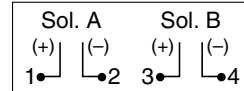

Parts List

Item No.	Part No.	Description
2	K463 001	End Spacer
* 3	—	O-Ring
4	K453 008	Spacer
5	K343 045	Spool (All Ports Blocked)
5	K343 067	Spool (Cyl. Ports Open to Inlet)
5	K343 068	Spool (Cyl. Ports Open to Exh.)
* 6	—	Seal
* 8	—	Seal
9	K313 017	Piston
*10	—	Seal
*14	—	Gasket
16	H175 12	Lockwasher
17	H100 60	Cap Screw
*18	—	Gasket
24	K152 003	Override Assy.
25	H175 16	Lockwasher
26	H101 25	Cap Screw
28	K983 003	Shock Pad

* Standard Service Kit: K352 153
* Special Service Kit: K352 353 (Continuous Duty)

4-Way, 5-Port, 3-Position - 3/8" Thru 1-1/4" NPT Ports

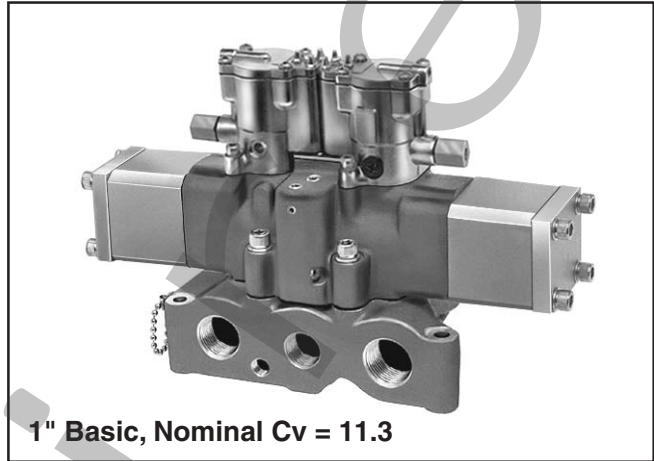
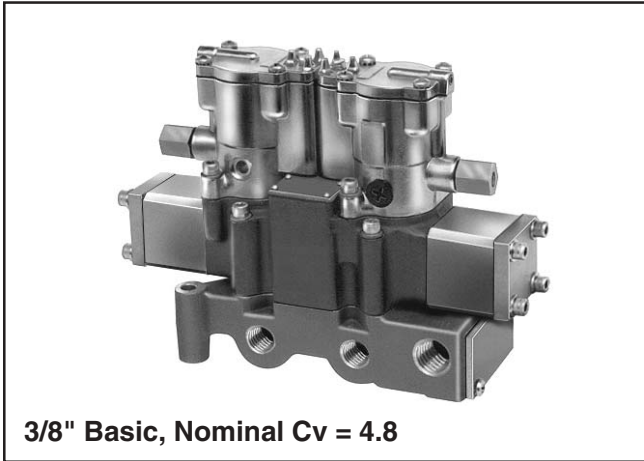

Application

These valves may be used to actuate double acting cylinders, when "inching" or incremental rod movement is desired. A "momentary" (exceeding .03 seconds) or maintained electrical signal applied to one of the solenoids shifts the valve, the valve returns to the "neutral" condition when the electrical signal is removed. Valve may be applied for alternate service. For alternate flow path usages, see *Optional Functions* page.

Mounting

These valves are designed for subbase or modular manifold mountings. Electrical connection from valve to base is automatic. Air & electrical connections remain undisturbed if valve is removed. Order from chart below.

Operation: Pressure Service

Neutral "Class 21"

Both solenoids de-energized (Normal Condition) – All ports blocked.

Neutral "Class 22"

Both solenoids de-energized (Normal Condition) – "Cylinder" Port A is open to "Exhaust" Port EA, "Cylinder" Port B is open to "Exhaust" Port EB, "Pressure" Port P is blocked.

Neutral "Class 23"

Both solenoids de-energized (Normal Condition) – "Cylinder" Port A is open to Pressure Port P, "Cylinder" Port B is open to Pressure Port P. Both "Exhaust" Ports EA and EB are blocked.

Activated Operation

With solenoid "A" energized – Pressure at Port P flows to "Cylinder" Port A, "Cylinder" Port B is connected to "Exhaust" Port EB, regardless of neutral "class".

With solenoid "B" energized – Pressure at Port P flows to "Cylinder" Port B, "Cylinder" Port A is connected to "Exhaust" Port EA, regardless of neutral "class".

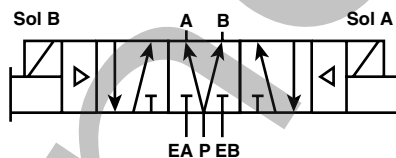
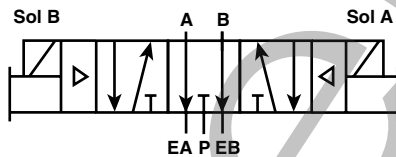
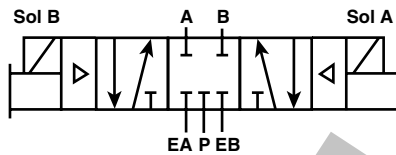

Model Selection (Neutral "Class 21" Shown)

Note: Shaded units are no longer available.

Valve Only	Voltage	Subbase (Side Ports)	Manifold ▲ (End & Bottom Ports)	Port Size (NPT)	Port Adapter
L665 39 211 53	120V 60Hz 110V 50Hz	K022 090	K142 230	3/8"	Not Req'd
		K022 091	K142 231	1/2"	
L665 33 211 **	Other	K022 101	K142 270	3/4"	K122 016 Kit Includes Both Ends
L665 89 211 53	120V 60Hz 110V 50Hz	K022 094	K142 235	3/4"	
		K022 095	K142 236	1"	
L665 83 211 **	Other	K022 096	K142 237	1-1/4"	

See page 5 for variations in class of neutral configuration and (**) voltage codes.

▲ - Manifolds include mounting hardware, except for port adapters. See chart, order separately.

Dimensional Data & Service Kits

L665, 3/8" & 1" Basic Valve

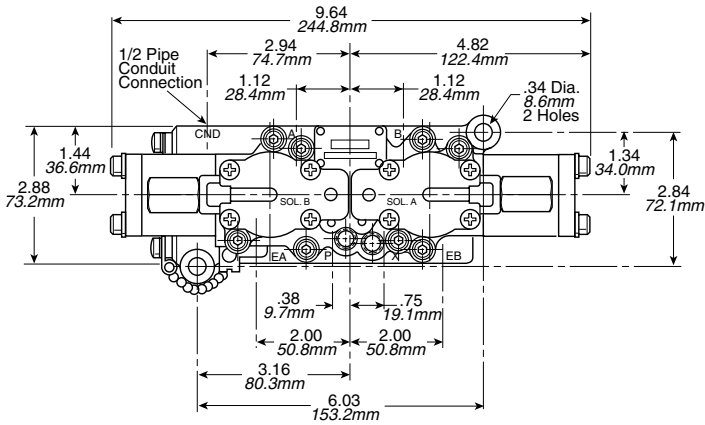

3/8" Basic
See Manifold Section for Manifold Dimensional Data

Wiring Diagram

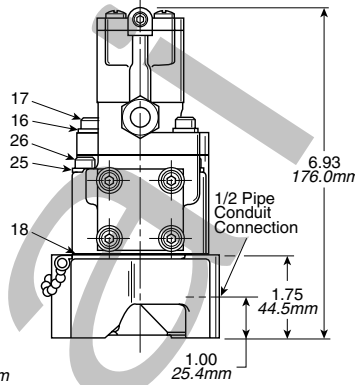
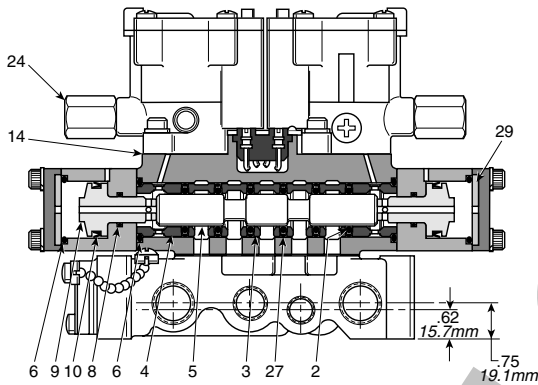
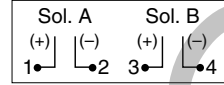

Parts List

Item No.	Part No.	Description
* 2	—	O-Ring (Dynamic)
3	K453 028	Spacer
4	K463 012	End Spacer
5	K343 124	Spool (All Ports Blocked)
5	K343 126	Spool (Cyl. Ports Open to Inlet)
5	K343 125	Spool (Cyl. Ports Open to Exh.)
* 6	—	Seal
* 8	—	Seal
9	K313 049	Piston
*10	—	Seal
*14	—	Gasket
16	H175 12	Lockwasher
17	H100 60	Cap Screw
*18	—	Gasket
24	K152 003	Override Assy.
25	H175 12	Lockwasher
26	H100 69	Cap Screw
*27	—	O-Ring (Static)
29	K983 002	Shock Pad

* Standard Service Kit: K352 126
* Special Service Kit: K352 127 (Continuous Duty)

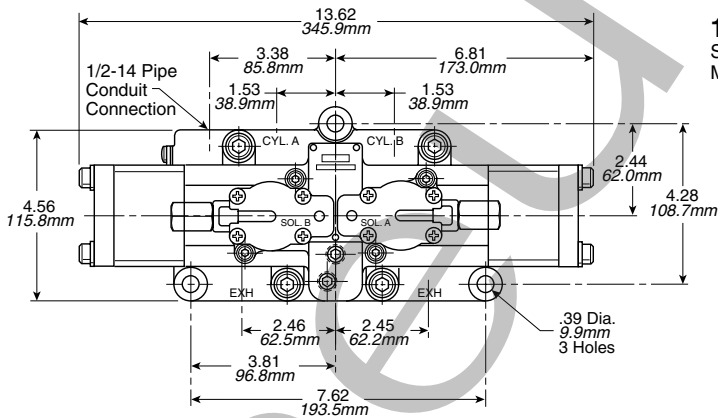

1" Basic
See Manifold Section for Manifold Dimensional Data

Wiring Diagram

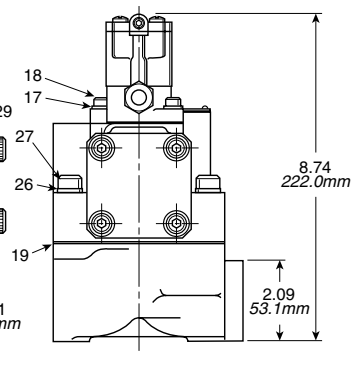
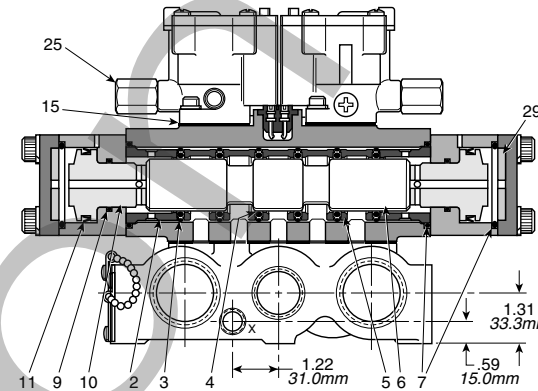
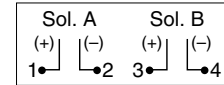

Parts List

Item No.	Part No.	Description
2	K463 005	End Spacer
* 3	—	O-Ring (Static)
* 4	—	O-Ring (Dynamic)
5	K453 009	Spacer
6	K343 060	Spool (All Ports Blocked)
6	K343 070	Spool (Cyl. Ports Open to Exh.)
6	K343 069	Spool (Cyl. Ports Open to Inlet)
* 7	—	Seal
* 9	—	Seal
10	K313 023	Piston
*11	—	Seal
*15	—	Gasket
17	H175 12	Lockwasher
18	H100 60	Cap Screw
*19	—	Gasket
25	K152 003	Override Assy.
26	H175 20	Washer
27	H101 48	Cap Screw
29	K983 004	Shock Pad

* Standard Service Kit: K352 130
* Special Service Kit: K352 131 (Continuous Duty)

4-Way, 4-Port, 3-Position & 4-Way, 5-Port, 3-Position - 1/4", 1/2" & 3/4" NPT

Ports

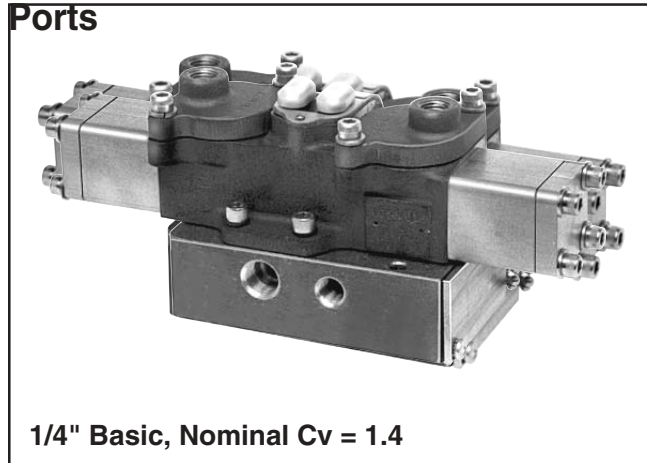

1/4" Basic, Nominal Cv = 1.4

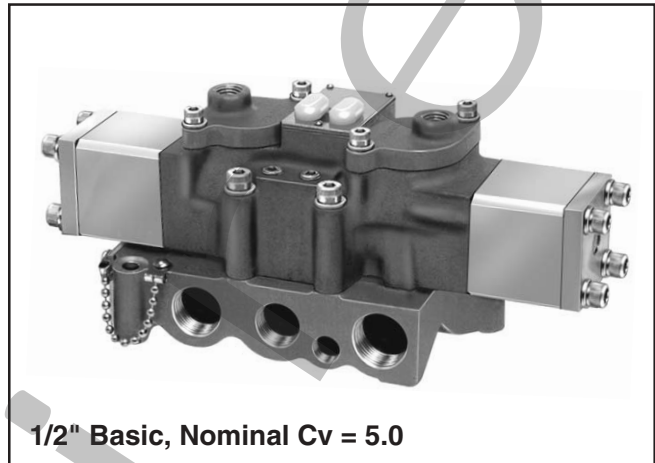

1/2" Basic, Nominal Cv = 5.0

Application

These valves may be used to actuate double acting cylinders when "inching" or incremental rod movement is desired. A normally open pilot signal to both pilot caps maintains the valve in its neutral (centered) condition. Valve may be applied for alternate service. For alternate flow path usages, see *Optional Functions* page.

Mounting

These valves are designed for subbase or modular manifold mountings. Order from chart below.

Operation: Pressure Service

Neutral "Class 21"

Normally open pilot signals to both pilot caps – All ports blocked.

Neutral "Class 22"

Normally open pilot signals to both pilot caps – "Cylinder" Port A is connected to "Exhaust" Port E (EA) and "Cylinder" Port B is connected to "Exhaust" Port E (EB). Pressure at Port P is blocked.

Neutral "Class 23"

Normally open pilot signals to both pilot caps – "Cylinder" Ports A and B are connected to Port P. "Exhaust" Port(s) E (EA and EB) are blocked.

Activated Operation

When Pilot "A" is exhausted – Pressure at Port P is connected to "Cylinder" Port A. "Exhaust" Port E (EB) is connected to "Cylinder" Port B.

When Pilot "B" is exhausted – Pressure at Port P is connected to "Cylinder" Port B. "Exhaust" Port E (EA) is connected to "Cylinder" Port A.

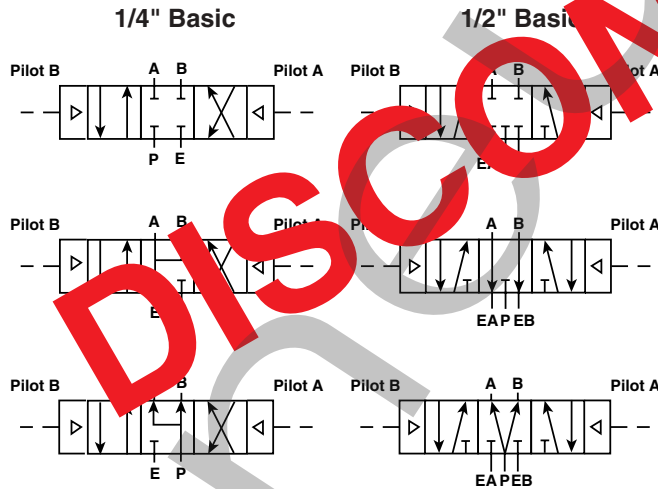

Model Selection

Note: Shaded units are no longer available.

Valve Only	Subbase (Side Ports)	Manifold (End & Bottom Ports) ▲			Port Size (NPT)
		2 Station	3 Station	Modular	
L424 21 211	K022 097	K142 077	K142 076	—	1/4"
L524 51 211	K022 092	—	—	K142 233	1/2"
	K022 093	—	—	K142 234	3/4"

See page 4 & 5 for variations in class of neutral configurations.

▲ - Manifolds include mounting hardware.

Dimensional Data & Service Kits

L424 & L524, 1/4" & 1/2" Basic Valve

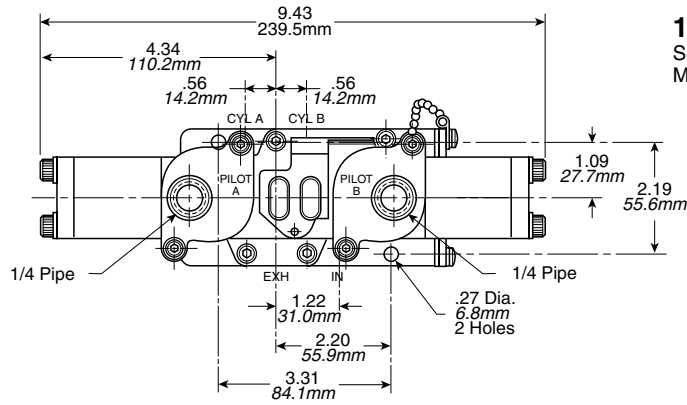

1/4" Basic
 See Manifold Section for Manifold Dimensional Data

Parts List

Item No.	Part No.	Description
* 2	—	O-Ring
3	K453 005	Spacer
4	K343 020	Spool (All Ports Blocked)
4	K343 021	Spool (Cyl. Ports Open to Inlet)
4	K343 073	Spool (Cyl. Ports Open to Exh.)
5	K313 009	Piston (Long)
6	K313 010	Piston (Short)
* 7	—	Seal
* 8	—	Seal
* 9	—	Seal
10	K323 027	Remote Cap
11	K333 013	Plug Cap
*15	—	Gasket
17	H175 12	Lockwasher
18	H100 60	Cap Screw
19	H100 59	Cap Screw
20	H175 12	Lockwasher
*21	—	Gasket

* Standard Service Kit: K352 357

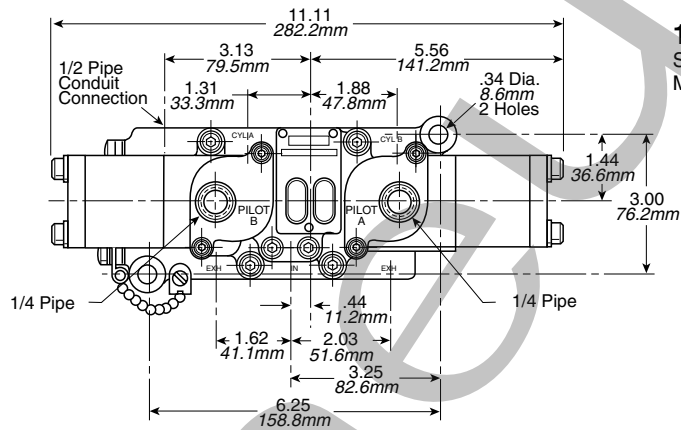
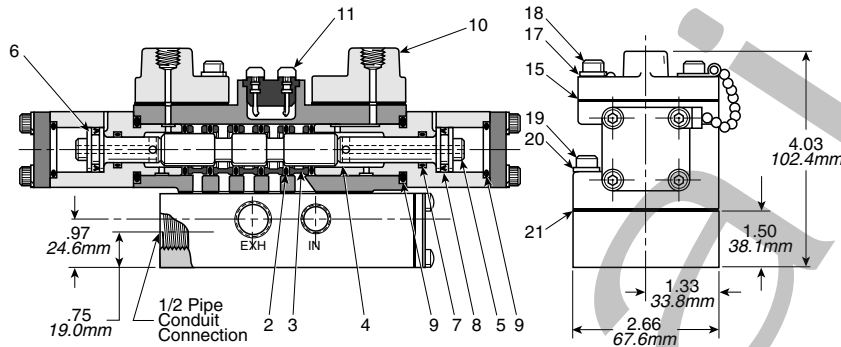

1/2" Basic
 See Manifold Section for Manifold Dimensional Data

Parts List

Item No.	Part No.	Description
2	K463 001	End Spacer
* 3	—	O-Ring
4	K453 008	Spacer
5	K343 045	Spool (All Ports Blocked)
5	K343 067	Spool (Cyl. Ports Open to Inlet)
5	K343 068	Spool (Cyl. Ports Open to Exh.)
* 6	—	Seal
* 8	—	Seal
9	K313 017	Piston
*10	—	Seal
13	K323 027	Remote Cap
*14	—	Gasket
15	K333 013	Plug Cap
16	H175 12	Lockwasher
17	H100 60	Cap Screw
*18	—	Gasket
25	H175 16	Lockwasher
26	H101 25	Cap Screw
28	K983 003	Shock Pad

* Standard Service Kit: K352 358

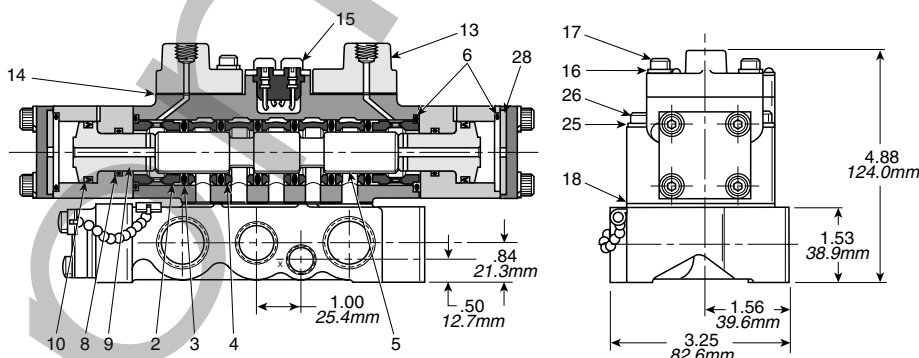

4-Way, 5-Port, 3-Position - 3/8" Thru 1-1/4" NPT Ports

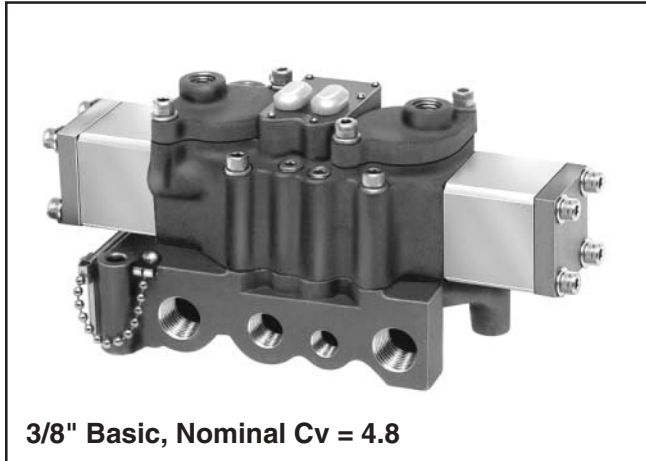

3/8" Basic, Nominal Cv = 4.8

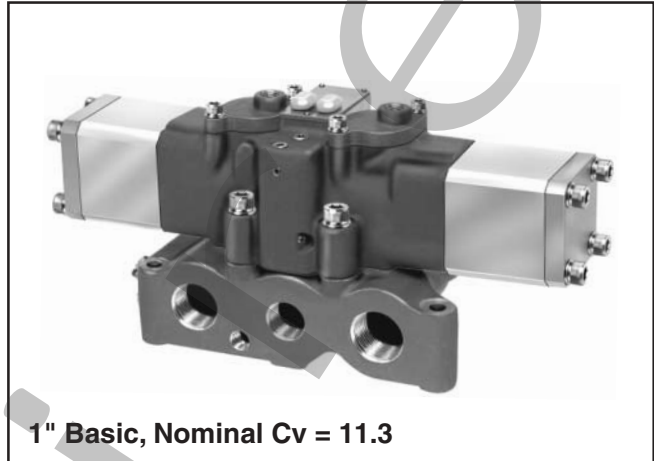

1" Basic, Nominal Cv = 11.3

Application

These valves may be used to activate double acting cylinders when "inching" or incremental rod movement is desired. A normally open pilot signal to both pilot caps maintains the valve in its neutral (centered) condition. Valve may be applied for alternate services. For alternate flow path usages, see *Optional Functions* page.

Mounting

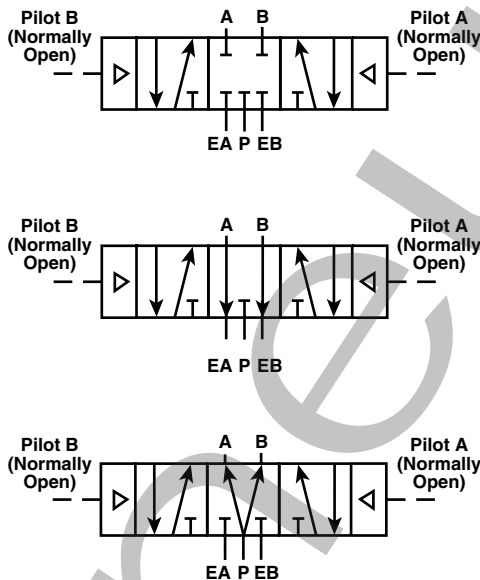

These valves are designed for subbase or modular manifold mountings. Order from chart below.

Operation: Pressure Service

Neutral "Class 21"

Normally open pilot signals to both pilot caps – All ports blocked.

Neutral "Class 22"

Normally open pilot signals to both pilot caps – "Cylinder" Port A is connected to "Exhaust" Port EA and "Cylinder" Port B is connected to "Exhaust" Port EB. Pressure at Port P is blocked.

Neutral "Class 23"

Normally open pilot signals to both pilot caps – "Cylinder" Ports A & B are connected to Port P. "Exhaust" Ports EA & EB are blocked.

Activated Operation

When Pilot "A" is exhausted – Pressure at Port P is connected to "Cylinder" Port A. "Exhaust" Port EB is connected to "Cylinder" Port B.

When Pilot "B" is exhausted – Pressure at Port P is connected to "Cylinder" Port B. "Exhaust" Port EA is connected to "Cylinder" Port A.

Model Selection (Neutral "Class 21" Shown)

Note: Shaded units are no longer available.

Valve Only	Subbase (Side Ports)	Manifold ▲ (End & Bottom Ports)	Port Size (NPT)	Port Adapter
L664 31 211	K022 090	K142 230	3/8"	Not Req'd
	K022 091	K142 231	1/2"	
	K022 101	K142 270	3/4"	
L664 81 211	K022 094	K142 235	3/4"	K122 016 Kit Includes Both Ends
	K022 095	K142 236	1"	
	K022 096	K142 237	1-1/4"	

See page 5 for variations in class of neutral configurations.

▲ - Manifolds include mounting hardware.

Dimensional Data & Service Kits

L664, 3/8" & 1" Basic Valve

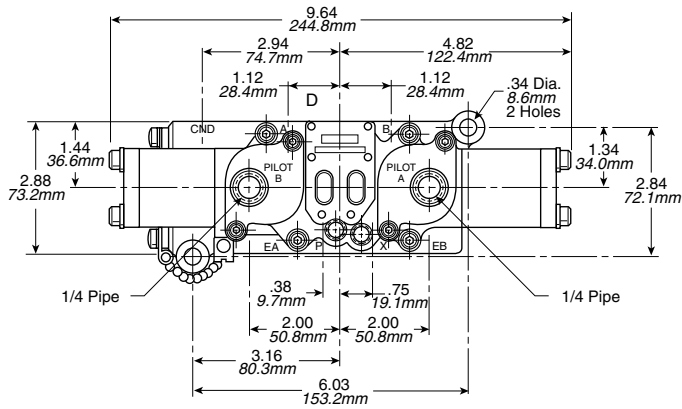

3/8" Basic
See Manifold Section for Manifold Dimensional Data

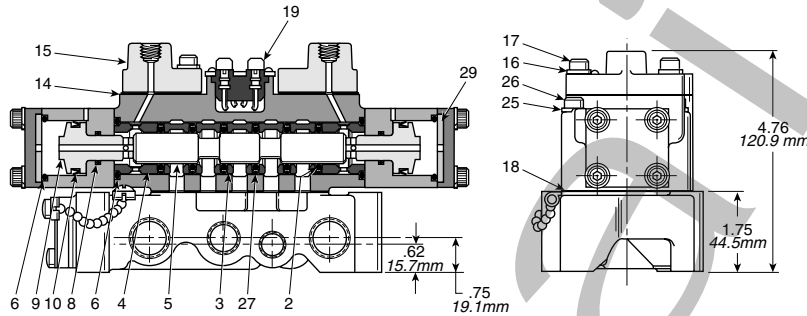

1" Basic
See Manifold Section for Manifold Dimensional Data

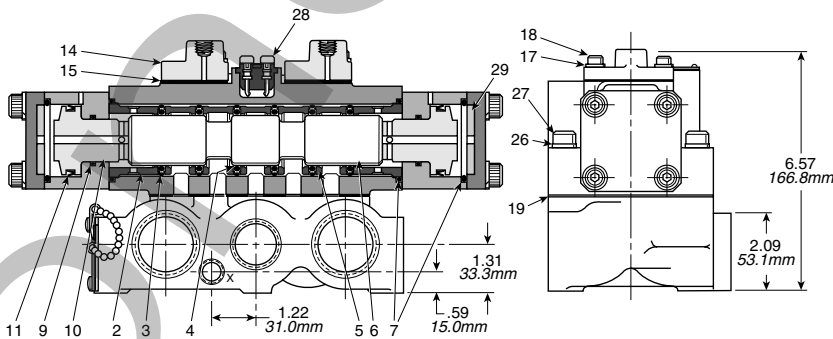
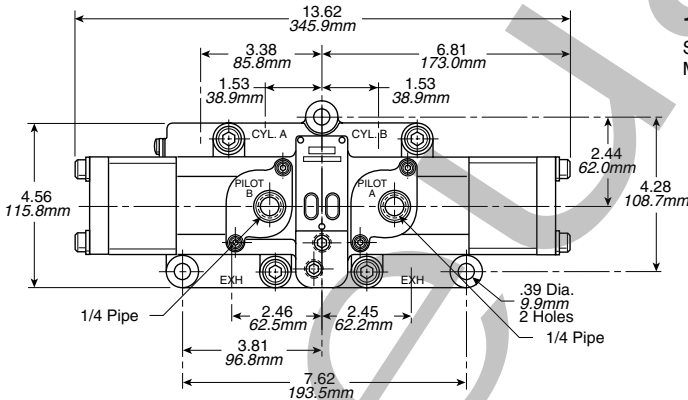

Parts List

Item No.	Part No.	Description
* 2	—	O-Ring (Dynamic)
3	K453 028	Spacer
4	K463 012	End Spacer
5	K343 124	Spool (All Ports Blocked)
5	K343 126	Spool (Cyl. Ports Open to Inlet)
5	K343 125	Spool (Cyl. Ports Open to Exh.)
* 6	—	Seal
* 8	—	Seal
9	K313 049	Piston
*10	—	Seal
*14	—	Gasket
15	K323 027	Remote Cap
16	H175 12	Lockwasher
17	H100 60	Cap Screw
*18	—	Gasket
25	H175 12	Lockwasher
26	H100 69	Cap Screw
*27	—	O-Ring (Static)
28	K333 013	Plug Cap
29	K983 002	Shock Pad

* Standard Service Kit: K352 355

Parts List

Item No.	Part No.	Description
2	K463 005	End Spacer
* 3	—	O-Ring (Static)
* 4	—	O-Ring (Dynamic)
5	K453 009	Spacer
6	K343 060	Spool (All Ports Blocked)
6	K343 070	Spool (Cyl. Ports Open to Exh.)
6	K343 069	Spool (Cyl. Ports Open to Inlet)
* 7	—	Seal
* 9	—	Seal
10	K313 023	Piston
*11	—	Seal
14	K323 027	Remote Cap
*15	—	Gasket
17	H175 12	Lockwasher
18	H100 60	Cap Screw
*19	—	Gasket
26	H175 20	Lockwasher
27	H101 48	Cap Screw
28	K333 013	Plug Cap
29	K983 004	Shock Pad

* Standard Service Kit: K352 360

Ordering Information

When Ordering Valve & Manifold Assemblies

1. Factory assembly instructions – valve & manifold (or subbase) to be assembled. Sequence of assembly to be as listed on order (see example) from left to right when facing end cylinder ports.

2. Size – identified as 5th character in Valve Model Number.

- 2 = 1/4" Basic L□□□2□ □□□ □□
- 3 = 3/8" Basic L□□□3□ □□□ □□
- 5 = 1/2" Basic L□□□5□ □□□ □□
- ▲ 8 = 1" Basic L□□□8□ □□□ □□

▲ (Port Plate K122 016 required on multi-station assemblies)

3. Number of stations:

00 = Single Subbase

01 = Single (Modular) Manifold (Do not use with 1/4" Basic Size)

02 = 2-Station

┌ ┌
* 12 = 12-Station

* More stations may be added, if there is sufficient upstream volume and pressure to insure that the last valve in the assembly will function. An increased upstream volume, conversion to an external pilot, or an additional inlet may prevent "starvation" problems on larger assemblies.

Manifold Assembly K 163 3 03

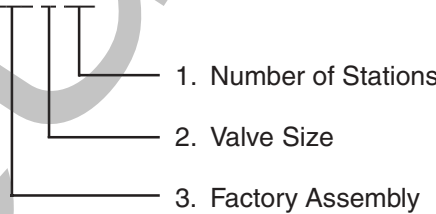

Example: L515 59 102 53
 K022 092
 K163 500

■ **Example:** L675 39 102 53
 K142 230
 L655 39 102 53
 K142 231
 L665 39 102 53
 K142 270
 K163 303

■ List items to be assembled as ordered Pairs and in "Sequence" of Assembly.

Dimensional Data

Plug-in Manifolds, 1/4" Basic Valve

- Suitable for mounting any combination of 1/4", 4-Way single or double solenoid Plug-In Valves.
- Common inlet, exhaust and electrical conduit ports simplify installation.
- Tapped for side or bottom cylinder port connections.
- Ganging manifolds end-to-end permits manifolding any desired number of valves.
- Integral Plug-In connections for safe, simple electrical connection of valve and manifold.

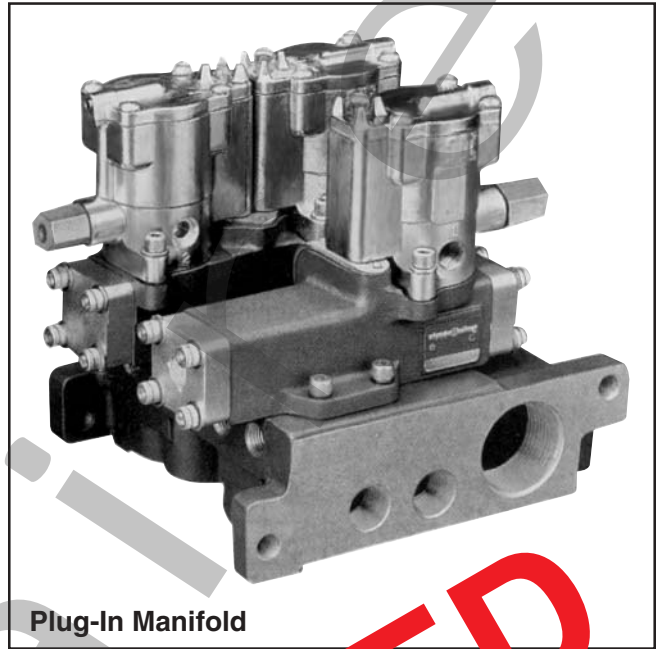

Plug-In Manifold

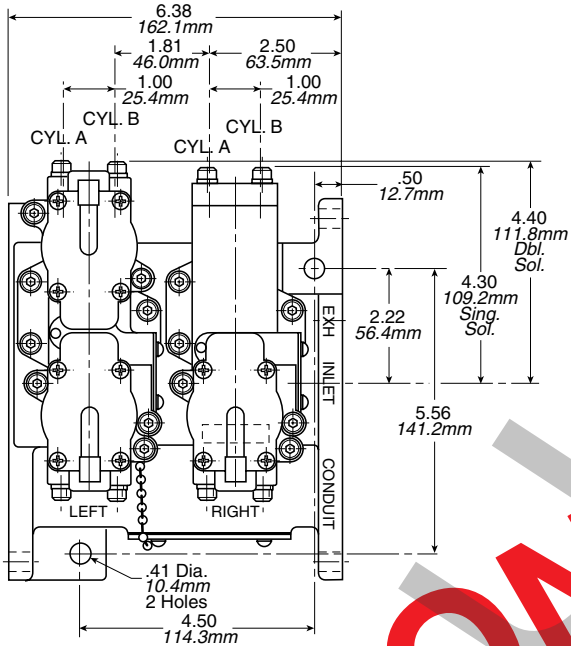

K142-077 Two-Station Manifold

Conduit Port	1/4" NPTF
Exhaust Port	1/2" NPTF
Inlet Port	1/2" NPTF
Conduit Port	1-1/4" NPTF

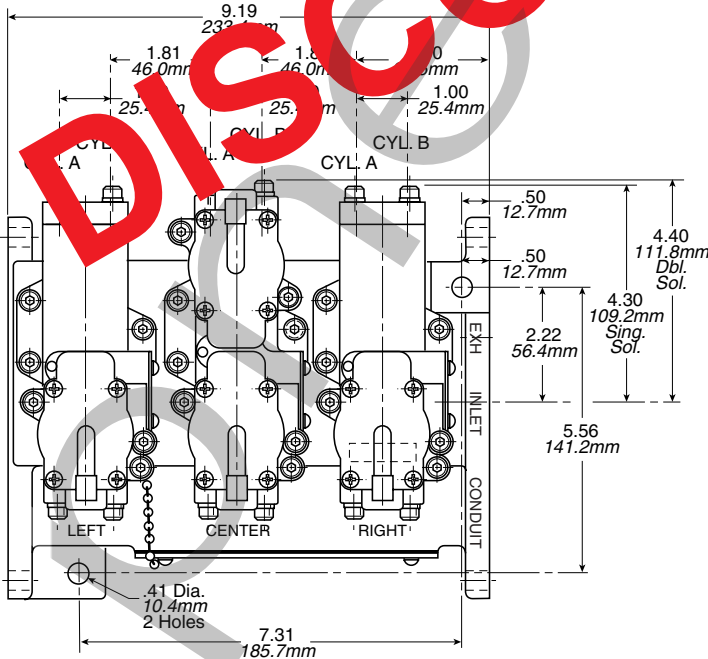

K142-076 Three-Station Manifold

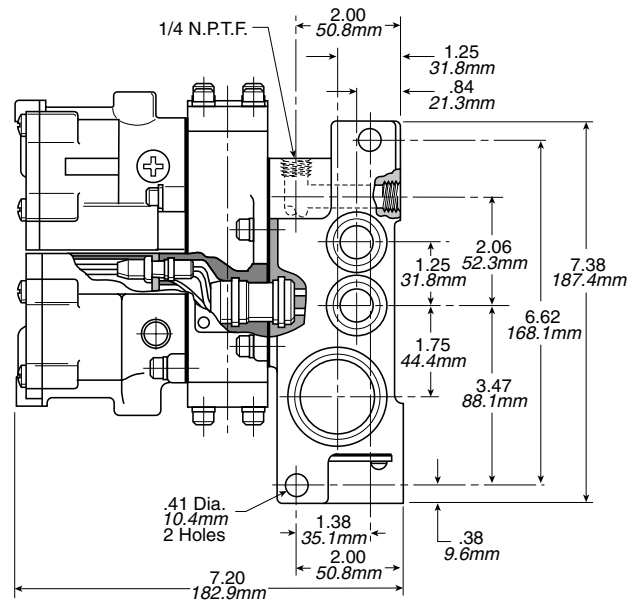

3/8" Basic

- K142 230 Cyl. Ports 3/8" NPTF
- K142 231 Cyl. Ports 1/2" NPTF
- K142 270 Cyl. Ports 3/4" NPTF
- Exhaust Port 1" NPTF
- Inlet Port 1" NPTF
- Conduit Port 1-1/4" NPTF

Note: Manifold assemblies include mounting hardware.

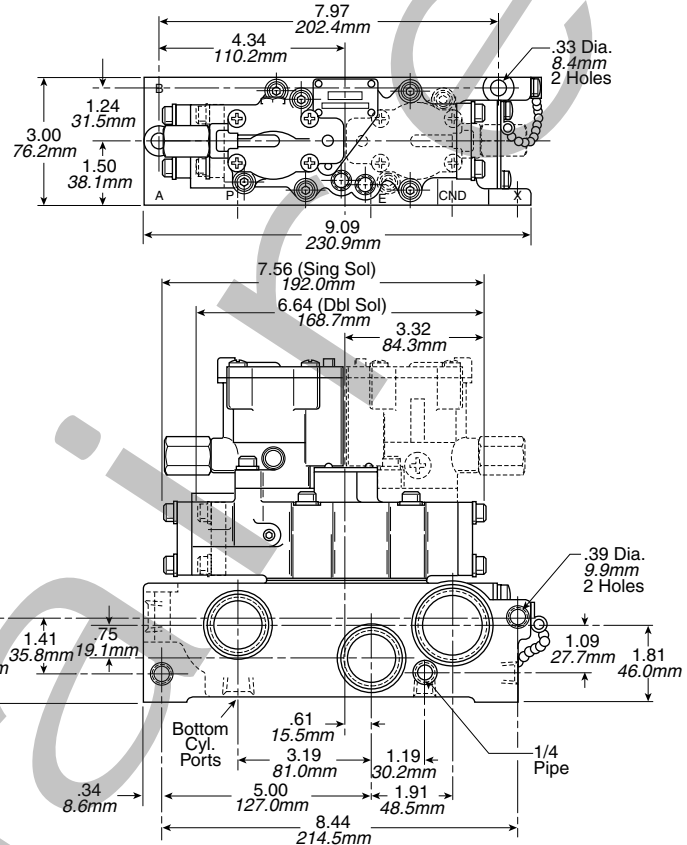
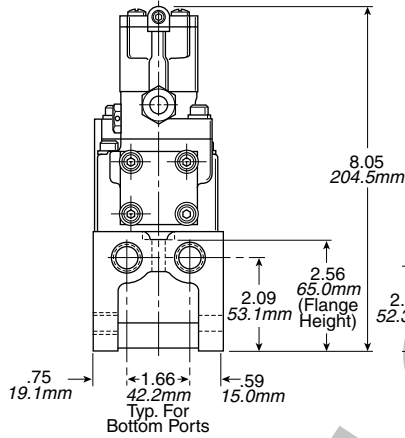

1/2" Basic

- K142 233 Cyl. Ports 1/2" NPTF
- K142 234 Cyl. Ports 3/4" NPTF
- Exhaust Port 1" NPTF
- Inlet Port 1" NPTF
- Conduit Port 1-1/4" NPTF

Note: Manifold assemblies include mounting hardware.

Note: Shaded units are no longer available.

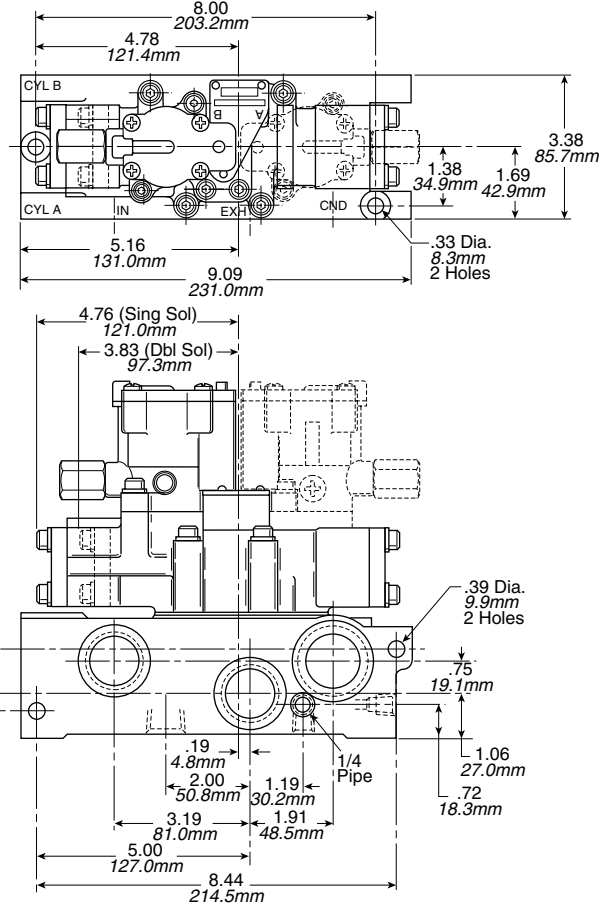
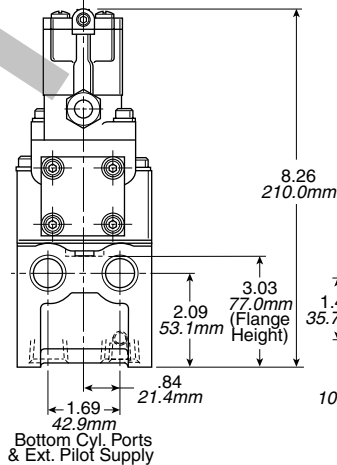

Plug-in Manifold Dimensional Data

1" Basic Valve

1" Basic

K142 235 Cyl. Ports 3/4" NPTF

K142 236 Cyl. Ports 1" NPTF

K142 237 Cyl. Ports 1-1/4" NPTF

K122 016 End Plate Kit (Both Plates)

Exhaust Port 1-1/2" NPTF (Port Plate)

Inlet Port 1-1/2" NPTF (Port Plate)

Conduit Port 1-1/4" NPTF (Port Plate)

Note: Shaded units are no longer available.

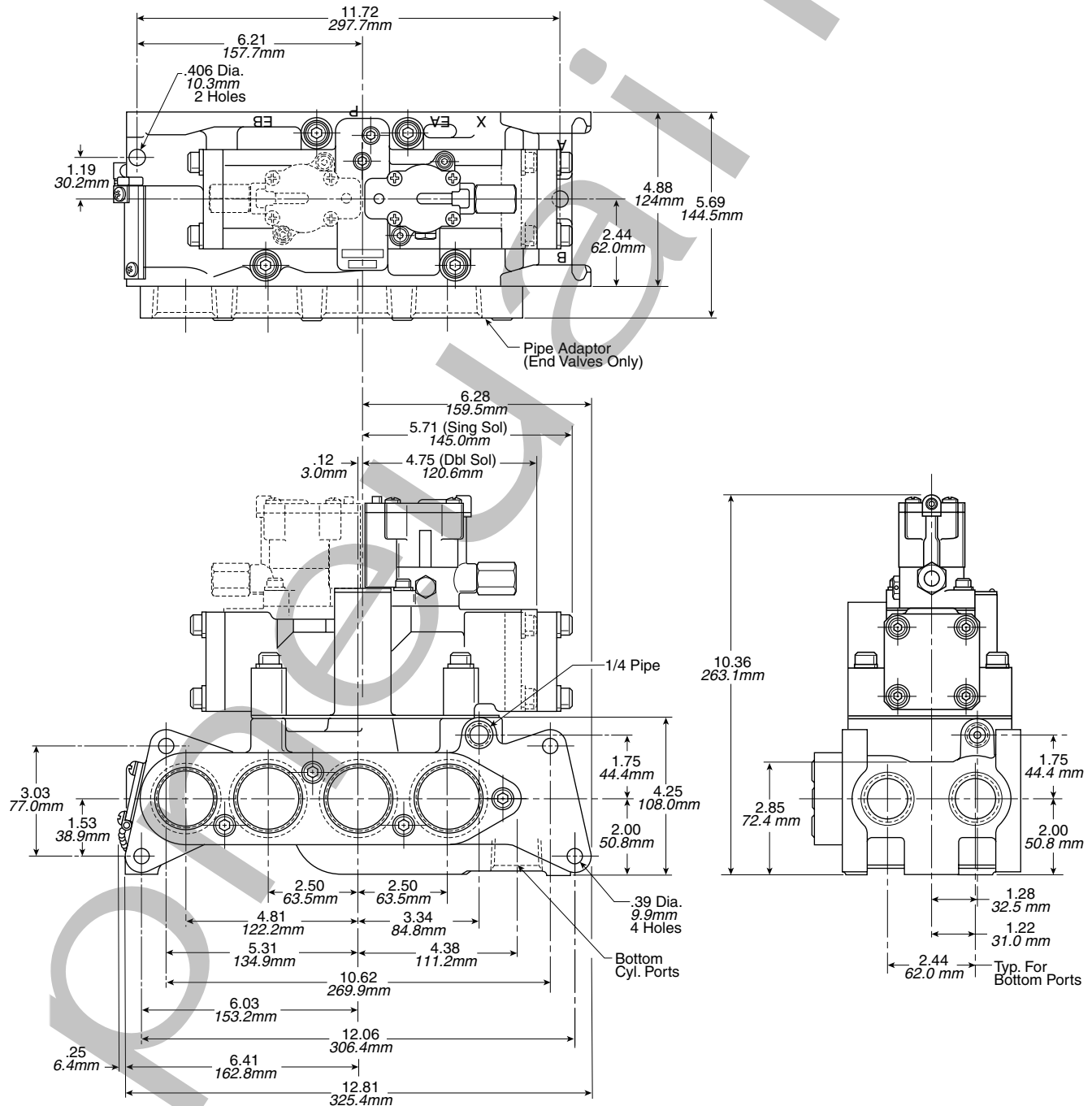

Features

Modular Pneumatic Controls Plug-In Sandwich Block Design for Modular Port Regulation

These modular regulators assemble to any 3/8" basic valve interface pattern.

Port Regulation Made Easy

Place the sandwich on the manifold or subbase, tighten the four securing screws, then plug the valve into the sandwich and tighten its securing screws to complete the assembly.

Within minutes, these modular components can be installed in new, or used to improve existing manifold systems, without disturbing wiring or air connections.

3-Configurations

1. **Common Port Regulation** - A common regulated pressure is selected to both cylinder ports.
2. **Single Port Regulation** - Line pressure is available to one cylinder port, while a single regulated pressure is selected to the other cylinder port.
3. **Independent Port Regulation** - Two independently regulated pressures selected to the cylinder ports.

NOTE: When using single or independent port sandwich regulators, be aware that:

1. Cylinder port outlets are reversed.
2. 3-Position, cylinder ports open to exhaust and cylinder ports open to inlet functions are reversed. To produce a cylinder ports open to exhaust function, order valve with cylinder ports open to inlet. To produce a cylinder ports open to inlet function, order valve with cylinder ports open to exhaust.

Manual or Remote secondary pressure adjustment.

Three Pressure Ranges are standard for manual units:

- 1-30 psig
- 1-60 psig
- 2-125 psig.

Range for Remote: 0-140 psig

Gauges are furnished standard, liquid filled gauges are optional.

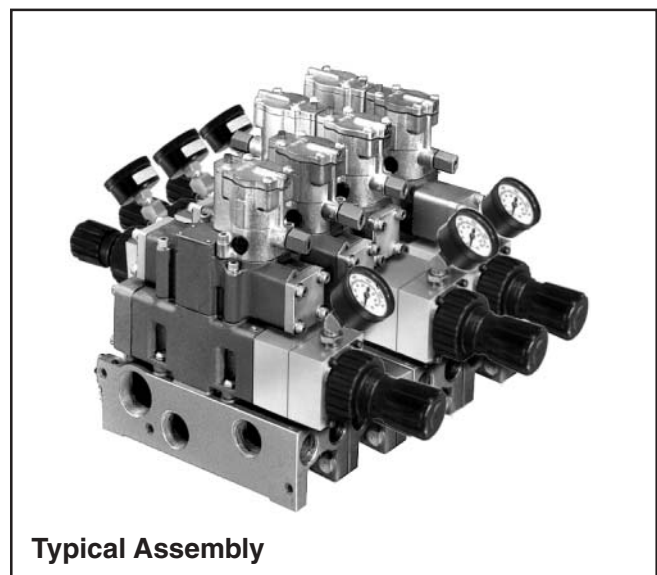
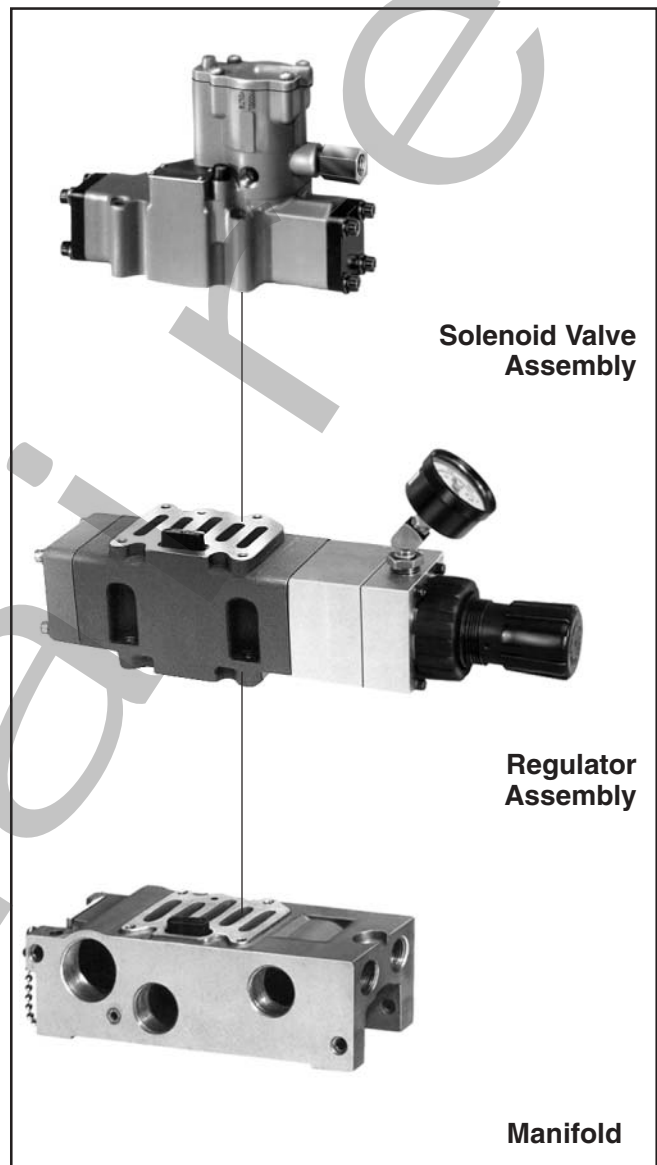

**RELIEF AND FLOW CHARACTERISTICS
COMMON PORT REGULATION**

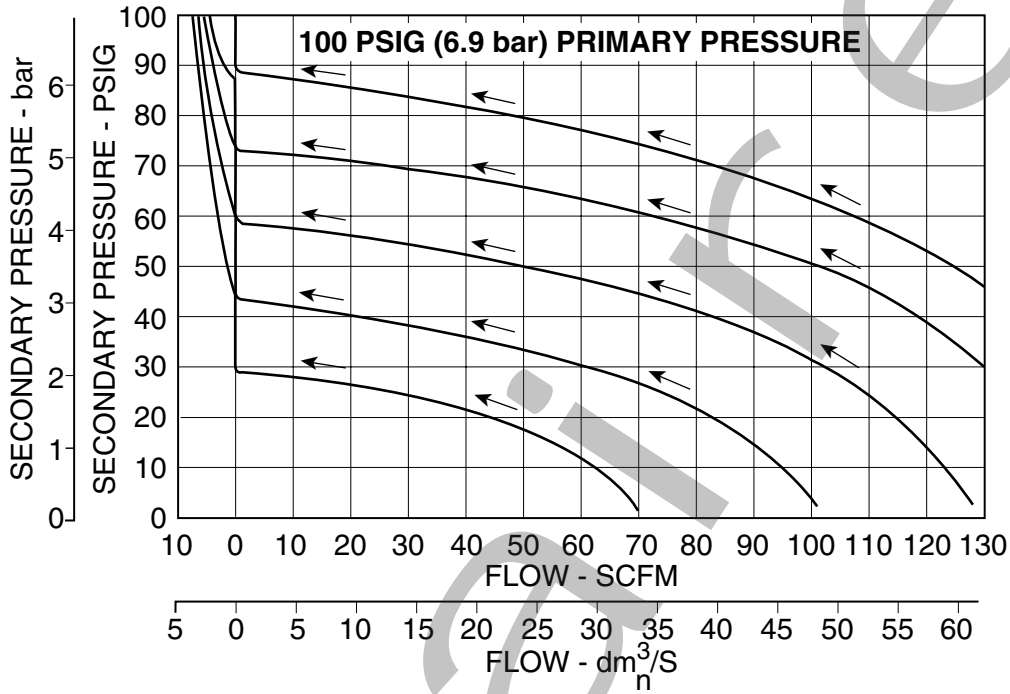

**RELIEF AND FLOW CHARACTERISTICS
INDEPENDENT OR SINGLE PORT REGULATION**

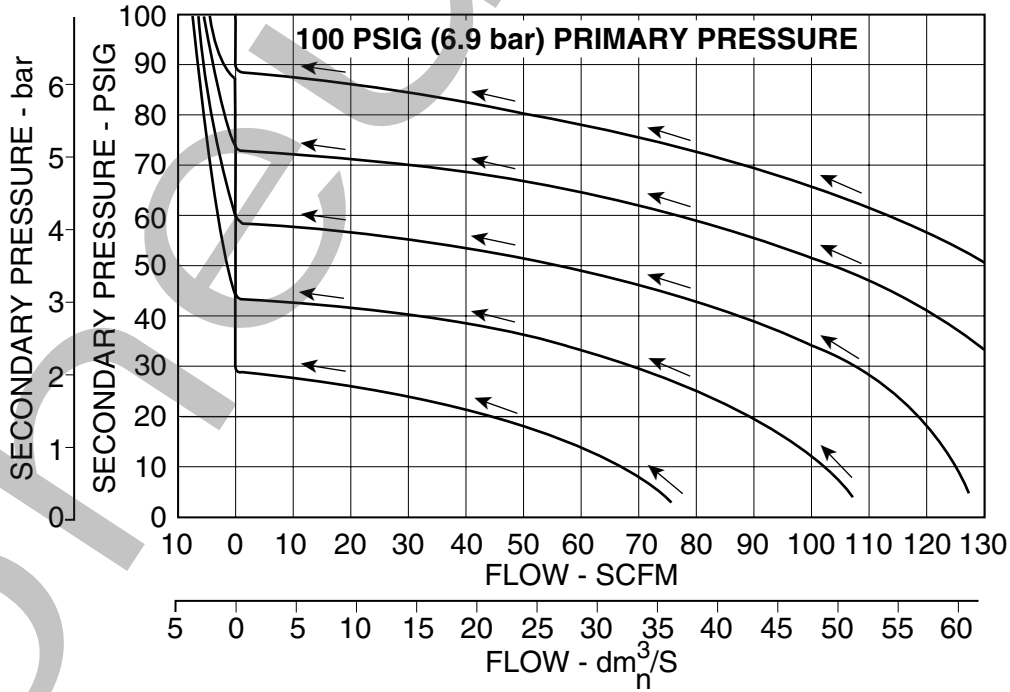

The above curves illustrate flow characteristics through an assembled valve, air regulator, and base (or modular manifold) unit.

Independent Port Regulation

Function

This modular air pressure regulation assembly, when installed between a 3/8" basic, 4-Way valve and subbase or modular manifold, supplies one or more regulated pressures to each of the valve cylinder ports.

Regulated pressure to cylinder port "A", and a second regulated pressure to cylinder port "B"; independently adjustable.

On Independent Cylinder Port Regulation Units controlled by a single solenoid valve, cylinder port "B" is the normally open cylinder port. The solenoid is energized to open cylinder port "A". On double solenoid operated valves, energizing solenoid "B" opens cylinder port "A" and energizing solenoid "A" opens cylinder port "B"

Valve must be converted to external pilot supply.

Features

Regulated pressure output from the valve is adjusted by knob on the manually set model or by air pressure signal applied to the regulator pilot port on the remotely set model.

Furnished with pressure gauge as standard.

The regulator controlling pressure to port "A" is mounted on the end opposite the electrical junction box (Assembly "A"). Regulated pressure from cylinder port "B" is controlled by the regulator installed over the electrical junction box (Assembly "B").

Pressure Range Options

Maximum Supply Pressure	140 psi
Output Pressure Range	1 - 30 psi
	1 - 60 psi
	2 - 125 psi

Operating Temperature Range

32°F (0°C) to 175°F (79°C)

How To Order

1. Select type of adjustment
2. Select pressure range for each cylinder port

Example: Manual adjusted.
5-60 psi range for cylinder port "A"
and 10-125 psi for cylinder port "B"
Model No. L554 06 305C

NOTE: When using single or independent port sandwich regulators, be aware that:

1. Cylinder port outlets are reversed.
2. 3-Position, cylinder ports open to exhaust and cylinder ports open to inlet functions are reversed. To produce a cylinder ports open to exhaust function, order valve with cylinder ports open to inlet. To produce a cylinder ports open to inlet function, order valve with cylinder ports open to exhaust.

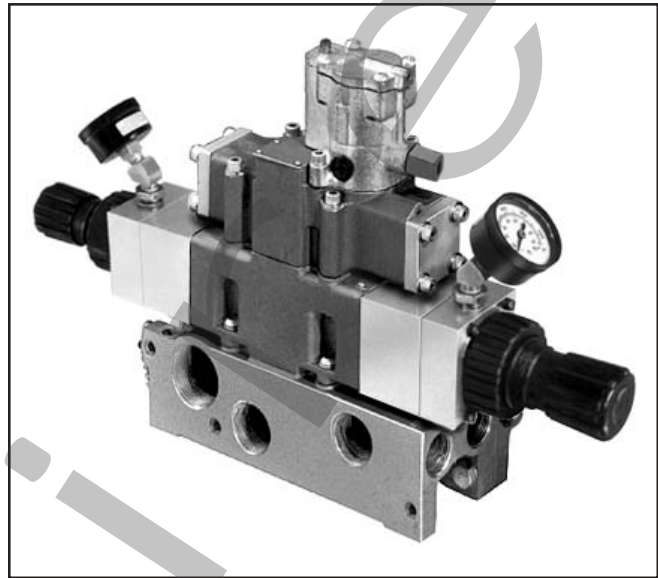

Graphic Symbol

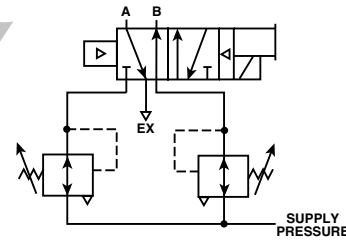

Independently Regulated Pressure at Both "A" & "B"

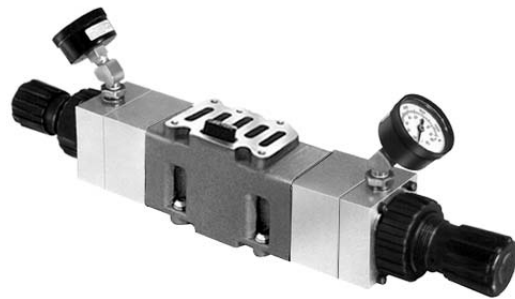

Pressure Adjustment	Cylinder Port "A" psi	Model Number		
		Cylinder Port "B"		
		5-30	5-60	10-125†
Manual	1 - 30	L554 04 304C	L554 04 305C	L554 04 306C
	1 - 60	L554 05 304C	L554 05 305C	L554 05 306C
	2 - 125	L554 06 304C	L554 06 305C	L554 06 306C
Manual with Liquid Filled Gauges	1 - 30	L554 30 330C	L554 30 331C	L554 30 332C
	1 - 60	L554 31 330C	L554 31 331C	L554 31 332C
	2 - 125	L554 32 330C	L554 32 331C	L554 32 332C
Remote	0 - 140	—	—	L554 14 314C†
Remote with Liquid Filled Gauges	0 - 140	—	—	L554 38 338C†

Note: Shaded units are no longer available.

† Remote operator units 0-140 PSI

* Assembly "A" places the regulator on the end opposite the electrical junction box. Assembly "B" places the regulator over the electrical junction box.

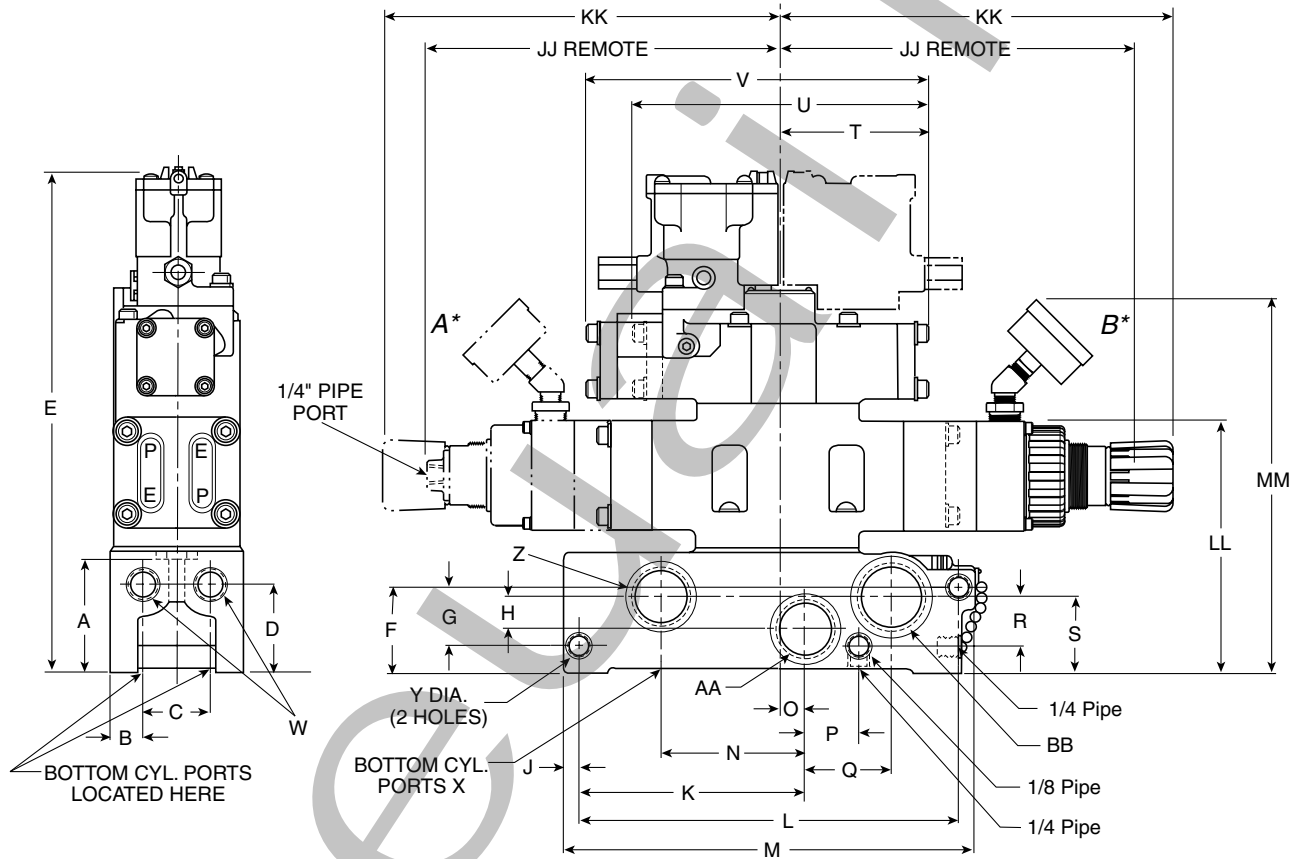
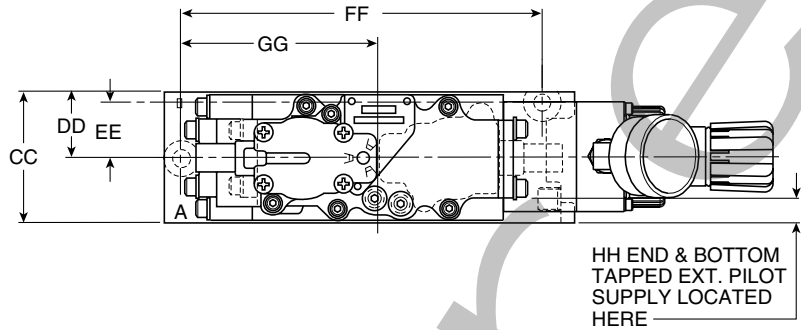

	A	B	C	D	E	F	G	H	J	K	L	M	N
inches	2.56	.75	1.50	2.09	11.28	2.06	1.41	.75	.34	5.00	8.44	9.09	3.19
mm	65.0	19.1	38.1	53.1	286.5	52.3	35.8	19.1	8.64	127.0	214.4	230.9	81.0
	O	P	Q	R	S	T	U	V	W	X	Y	Z	AA
inches	.61	1.19	1.91	1.09	1.81	3.32	6.64	7.56	3/8", 1/2" or 3/4" NPTF	.39	1"	1"	
mm	15.5	30.2	48.5	27.7	46.0	84.3	168.7	192.0					9.9
	BB	CC	DD	EE	FF	GG	HH	JJ	KK	LL	MM		
inches	1-1/4"	3.00	1.50	1.24	7.97	4.34	.40	8.53	10.15	5.46	8.80		
mm	NPTF	76.2	38.1	31.5	202.4	110.2	10.2	216.6	257.8	138.6	223.5		

Parts Data

Common Port Regulation
End Section Assemblies: See Tables 'A' or 'B'
Parts: See Table 'E'

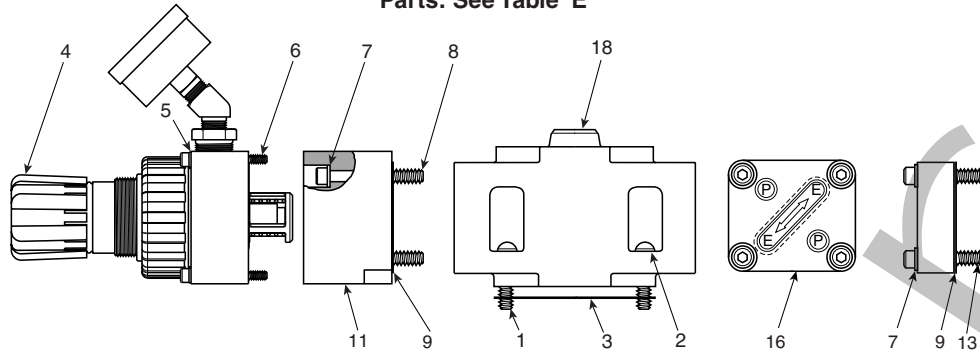

Table 'A'
Manual End Section
Common Port Regulation

psi	Standard	Liquid Filled
1-30	K362 301C	K362 327C
1-60	K362 302C	K362 328C
2-125	K362 303C	K362 329C

Table 'B'
Remote End Section
Common Port Regulation

psi	Standard	Liquid Filled
0-140	K362 311C	K362 335C

Single Port Regulation
End Section Assemblies: See Tables 'C' or 'D'
Parts: See Table 'E'

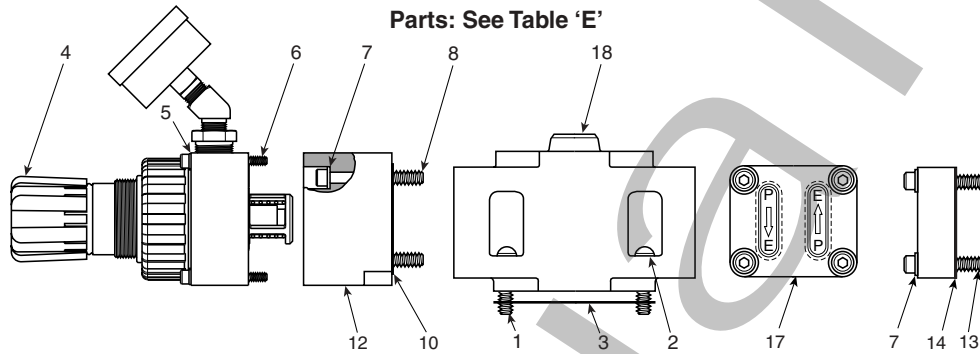

Table 'C'
Manual End Section
Single Independent Port
Regulation

psi	Standard	Liquid Filled
1-30	K362 304C	K362 330C
1-60	K362 305C	K362 331C
2-125	K362 306C	K362 332C

Table 'D'
Remote End Section
Single Independent Port
Regulation

psi	Standard	Liquid Filled
0-140	K362 314C	K362 338C

Independent Port Regulation
End Section Assemblies: See Tables 'C' or 'D'
Parts: See Table 'E'

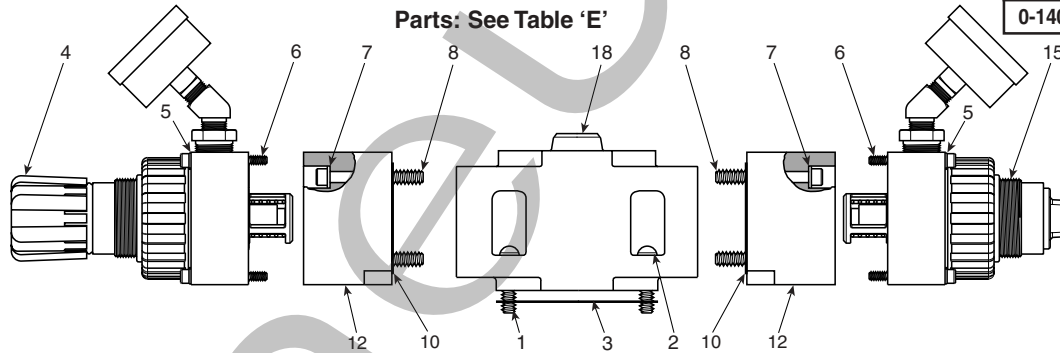
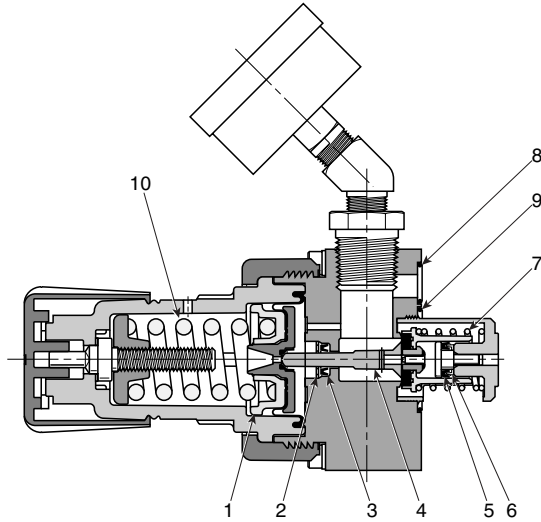

Table 'E': Parts

Item No.	Part Number	Description	Item No.	Part Number	Description	
1	H098 15	Screw (4)	9	K183 082	Gasket	
2	H175 12	Lockwasher (4)	10	K183 084	Gasket	
3	K183 077	Gasket	11	K043 012	Function Block (P to P)	
4	Standard	Liquid Filled	12	K043 011	Function Block (P to E)	
	K472 001C	K472 013C	1-30 psi	13	H100 107	1/4-20 x 1-1/2" Lg. SHCS
	K472 002C	K472 014C	1-60 psi	14	K183 083	Gasket
	K472 003C	K472 015C	2-125 psi	15	Standard	Liquid Filled
5	H175 09	#10 Lockwasher	K472 009C		K472 018C	0-140 psi
6	H100 32	#10-32 x 1.75" Lg. SHCS	16	K362 308	Function Plate Assy. (Incl. 7, 9, 13)	
7	H175 11	1/4" Lockwasher	17	K362 307	Function Plate Assy. (Incl. 7, 13, 14)	
8	H100 69	1/4-20 x 2.25" Lg. SHCS	18	K032 270	Body Assy. (Incl. 1, 2, 3)	

Manual Adjusting



Remote Operated

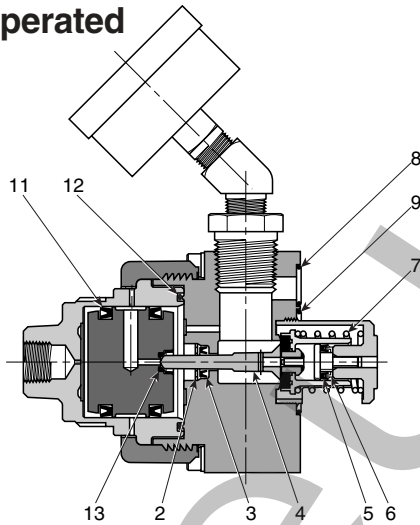

Replacement Parts

Item No.	Part Number	Description
1	○	Diaphragm Assembly
2	○ ●	Retaining Ring
3	○ ●	Vee Packing
4	○ ●	Poppet Assembly
5	○ ●	Vee Packing
6	○ ●	Backflow Retainer
7	○ ●	Poppet Spring
8	○ ●	.989 ID x .070 W O-Ring
9	○ ●	1.301 ID x .070 W O-Ring
10	P01698 P04062 P04063	1-30 PSI Spring 1-60 PSI Spring (Blue) 2-125 PSI Spring
11	●	Vee Packing
12	●	1.674 ID x .103 W O-Ring
13	●	Vent Seal

○ Parts included in K352409 Service Kit for Manual Operated Modular Regulators.

● Parts included in K352411 Service Kit for Remote Operated Modular Regulators.

Replacement Gauges

psi	Standard	Liquid Filled
0-60	3560 0400	H032 57
0-160	3560 0410	H032 58
0-300	3560 0420	—

Suggested Schematic of Assembled Valve, Air Regulation and Modular Manifold Units

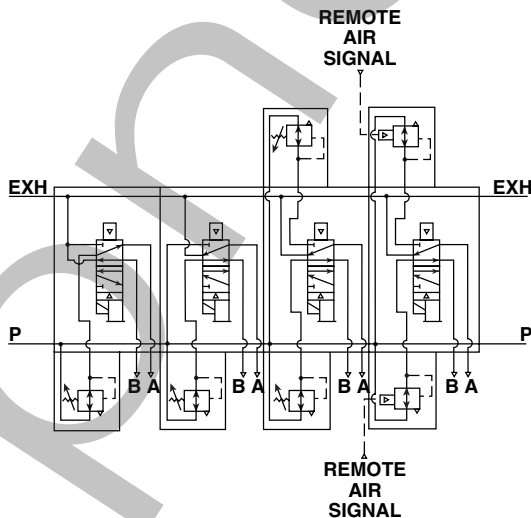

Basic Valve Features

- Full Air Operation for fastest response.
- "Direct Pipe" Design for economy and performance.
- Solenoids Interchange between all styles of direct pipe ported valves.
- Variety of Operators Available; Direct Conduit, (JIC) Junction Box, NEMA 4, Hazardous Duty, (UL, CSA), and remote air pilot.
- Locking Manual Overrides Standard. Non-locking overrides optional.
- Indicator Lights Standard on 120VAC and 24VDC models.
- Encapsulated Coil designed for low-power consumption and maximum life.
- Field Convertible to External Pilot Supply for vacuum or other services.
- "Oversized" Flow Areas.
- Synthetic Rubber O-Ring Seals are specially compounded for minimum compression and friction for superior wear and abrasion resistance.
- Precision Ground Spool "floats" on O-ring seals. Closed center cross-over design saves air.

De-Energized

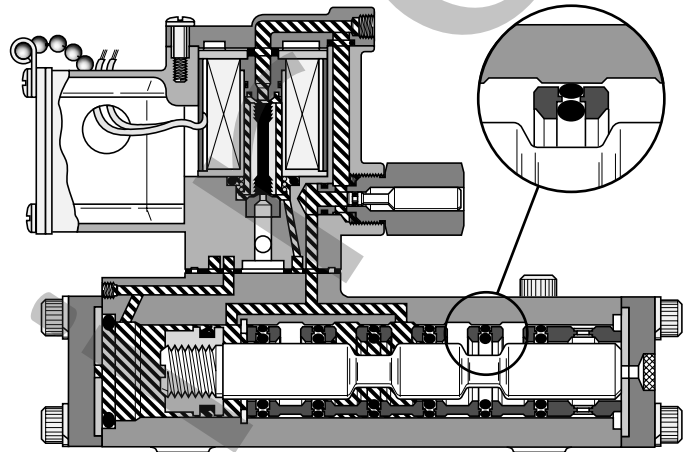

 Pressure  Exhaust

Energized

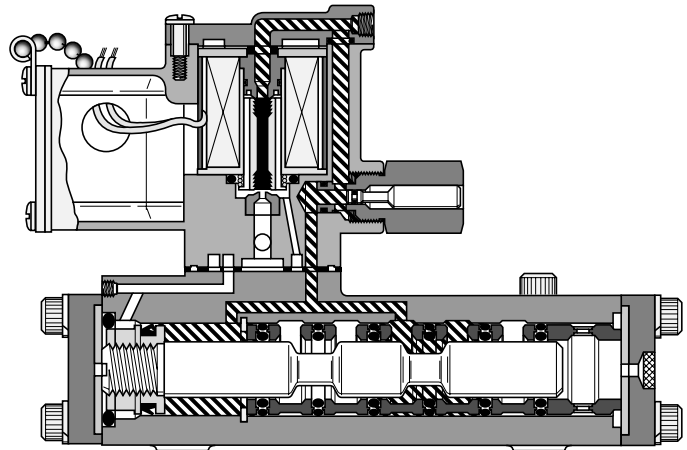

 Pressure  Exhaust

Speed King, SK-200 Valve Model Number System

Lubricated Service 2-Position - 1/4" Basic Size

Basic Series	Type	Operator	Size	Operator Options	Enclosure "Class"	Duty Cycle	Voltage & Frequency	Lead Length
L	48	5	2	9	10	2	53	L
	Type	Operator	Size			Duty Cycle		Lead Length
	46 Double 48 Single	4 Remote 5 Solenoid	2 1/4" NPT Inlet & Cyl. 3/8" NPT Exh. 3 3/8" NPT Inlet, Cyl. & Exh.			2 Standard Service Solenoid or Remote 4 Continuous Service Solenoid		Blank 19" (Standard) L 72" (Optional)
Operator Options					Enclosure "Class"		Voltage & Frequency	
1 Solenoid (Basic) or Remote 2 Solenoid w/Non-Locking Override 3 Solenoid w/Locking Override 4 Solenoid w/Jct. Box 5 Solenoid w/Jct. Box & Non-Locking Override 6 Solenoid w/Jct. Box & Locking Override 7 Solenoid w/Jct. Box & Light (120VAC, 24VDC) 8 Solenoid w/Jct. Box & Light (120VAC, 24VDC) & Non-Locking Override 9 Solenoid w/Jct. Box & Light (120VAC, 24VDC) & Locking Override					10 Standard (NEMA 1 & 12) or Remote 60 Hazardous Duty (NEMA 7 & 9) ■ * 80 NEMA 4 ■		60Hz 50Hz DC 45 12 49 24 53 120 110 57 240 220	
					■ Use with operator options 1, 2 & 3 only, voltage 53 only. * Voltage 49 / 53 only.			

Note: Shaded options have been discontinued. Refer to back of Catalog for Cross Reference Information.

Valvair II Valve Model Number System

Lubricated or Non-Lubricated Service 2-Position - 3/8" & 1" Basic Size

Basic Series	Type	Operator	Size	Operator Options	Enclosure "Class"	Duty Cycle	Voltage & Frequency	Lead Length
L	70	5	3	9	10	2	53	L
	Type	Operator	Size			Duty Cycle		Lead Length
	68 Double 70 Single	4 Remote 5 Solenoid	3 3/8" NPT Inlet & Cyl. 1/2" NPT Exh. 4 1/2" NPT Inlet, Cyl. & Exh. 7 3/4" NPT Inlet & Cyl. 1" NPT Exh. 8 1" NPT Inlet & Cyl. 1-1/4" NPT Exh. 9 1-1/4" NPT Inlet Cyl. & Exh. *			2 Standard Service Solenoid or Remote 4 Continuous Service Solenoid		Blank 19" (Standard) L 72" (Optional)
Operator Options					Enclosure "Class"		Voltage & Frequency	
1 Solenoid (Basic) or Remote 2 Solenoid w/Non-Locking Override 3 Solenoid w/Locking Override 4 Solenoid w/Jct. Box 5 Solenoid w/Jct. Box & Non-Locking Override 6 Solenoid w/Jct. Box & Locking Override 7 Solenoid w/Jct. Box & Light (120VAC, 24VDC) 8 Solenoid w/Jct. Box & Light (120VAC, 24VDC) & Non-Locking Override 9 Solenoid w/Jct. Box & Light (120VAC, 24VDC) & Locking Override					10 Standard (NEMA 1 & 12) or Remote 60 Hazardous Duty (NEMA 7 & 9) ■ * 80 NEMA 4 ■		60Hz 50Hz DC 45 12 49 24 53 120 110 57 240 220	
				* Not available operator option 4 - Remote Pilot.	■ Use with operator options 1, 2 & 3 only, voltage 53 only. * Voltage 49 / 53 only.			

Note: Shaded options have been discontinued. Refer to back of Catalog for Cross Reference Information.

Speed King, SK-200 Valve Model Number System

Lubricated Service
 2-Position
 1/2" Basic Size

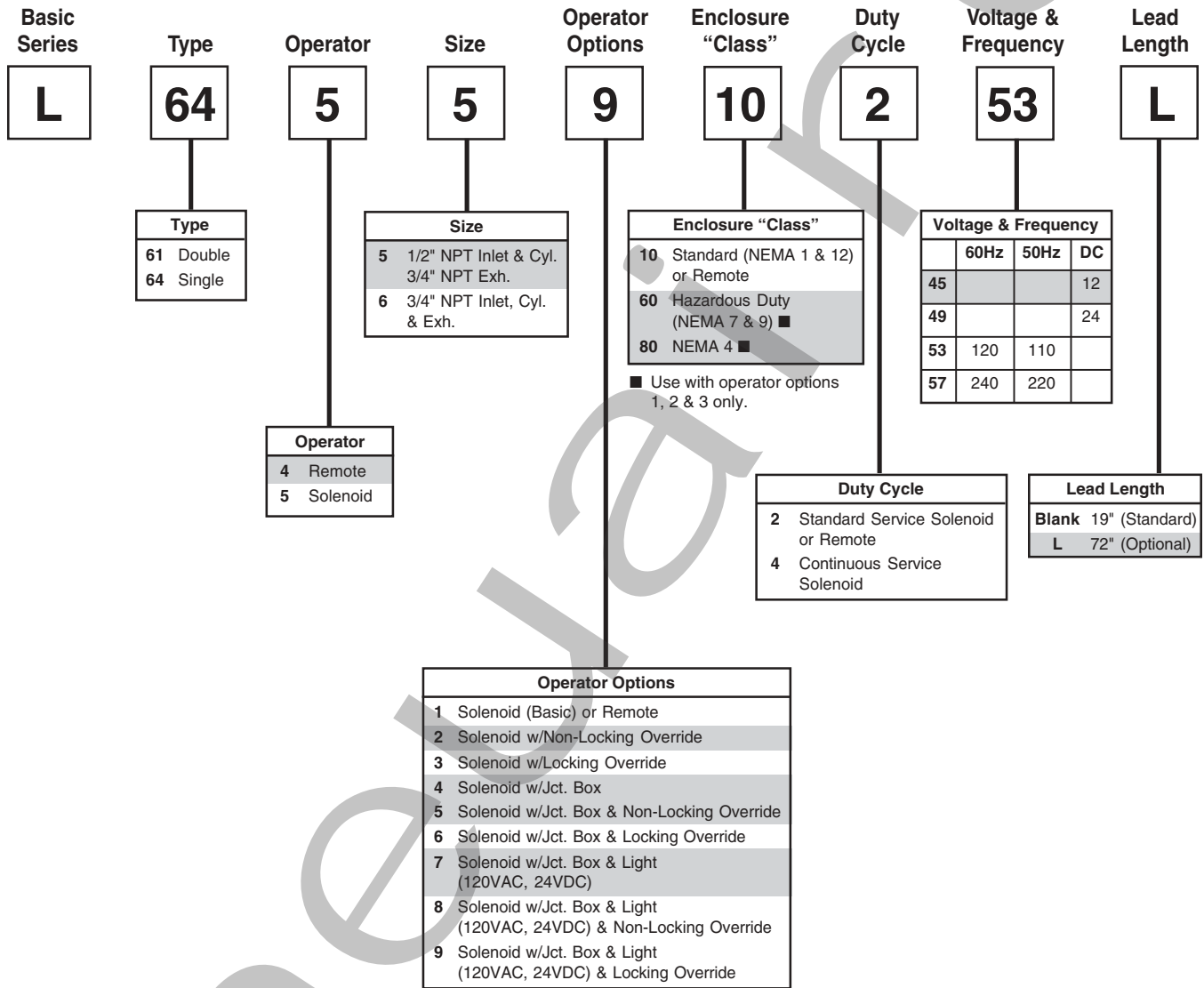

Note: Shaded options have been discontinued. Refer to back of Catalog for Cross Reference Information.

Speed King, SK-200 Valve Model Number System

Lubricated Service
 3-Position
 1/4" Basic Size

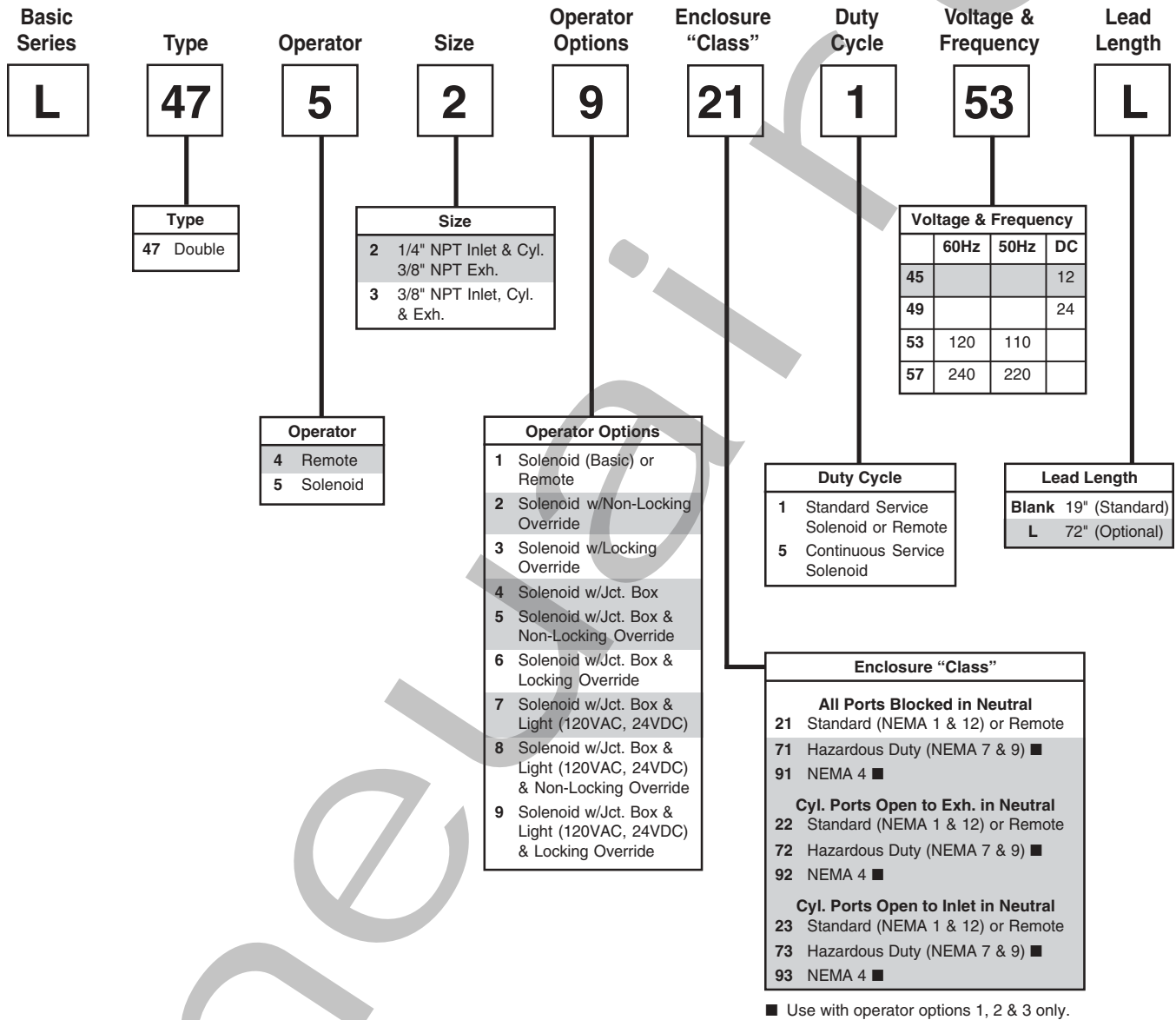

Note: Shaded options have been discontinued. Refer to back of Catalog for Cross Reference Information.

Valvair II Valve Model Number System

Lubricated or Non-Lubricated Service
 3-Position
 3/8" & 1" Basic Size

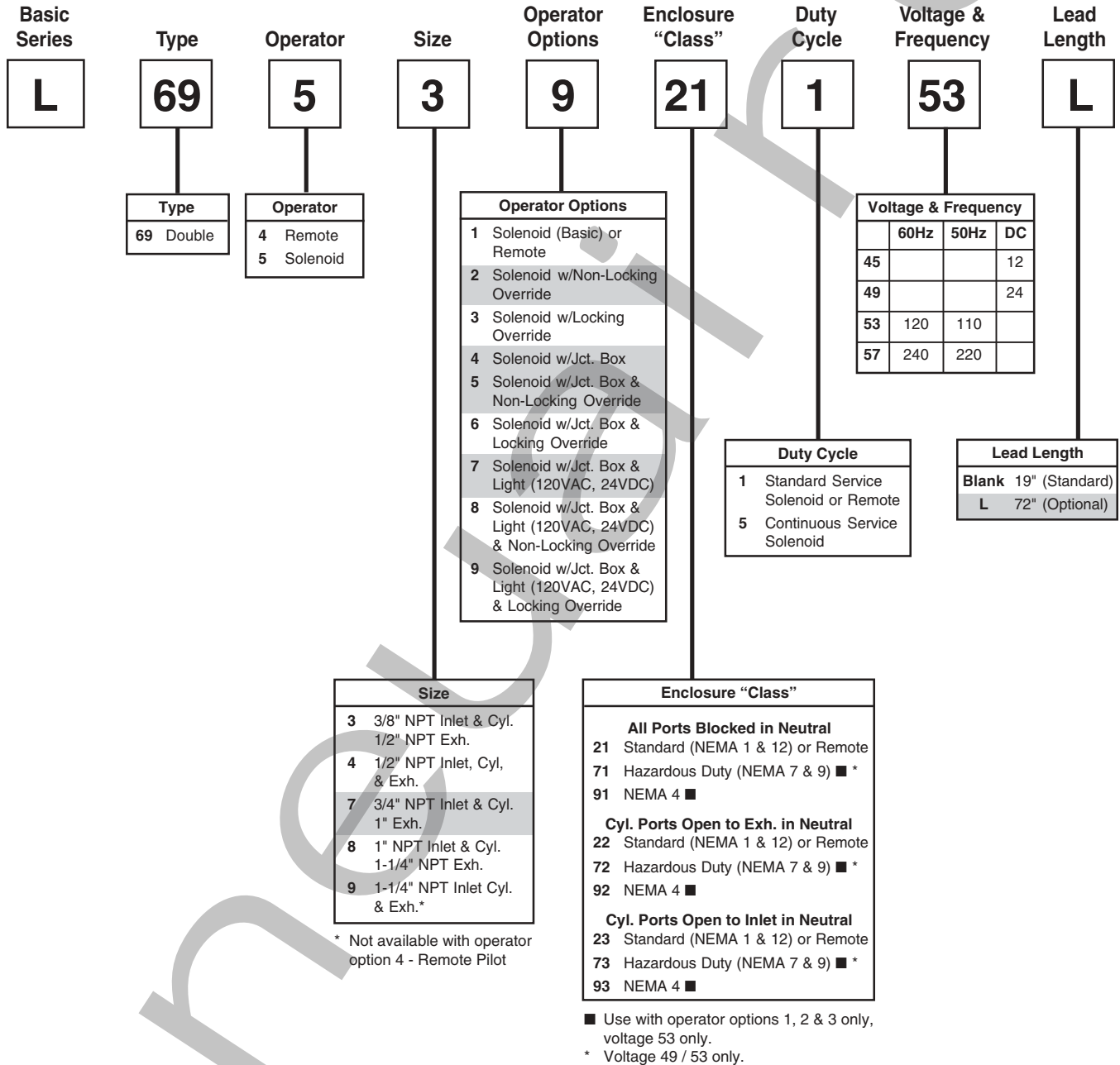

Note: Shaded options have been discontinued. Refer to back of Catalog for Cross Reference Information.

Speed King, SK-200 Valve Model Number System

Lubricated Service
 3-Position
 1/2" Basic Size

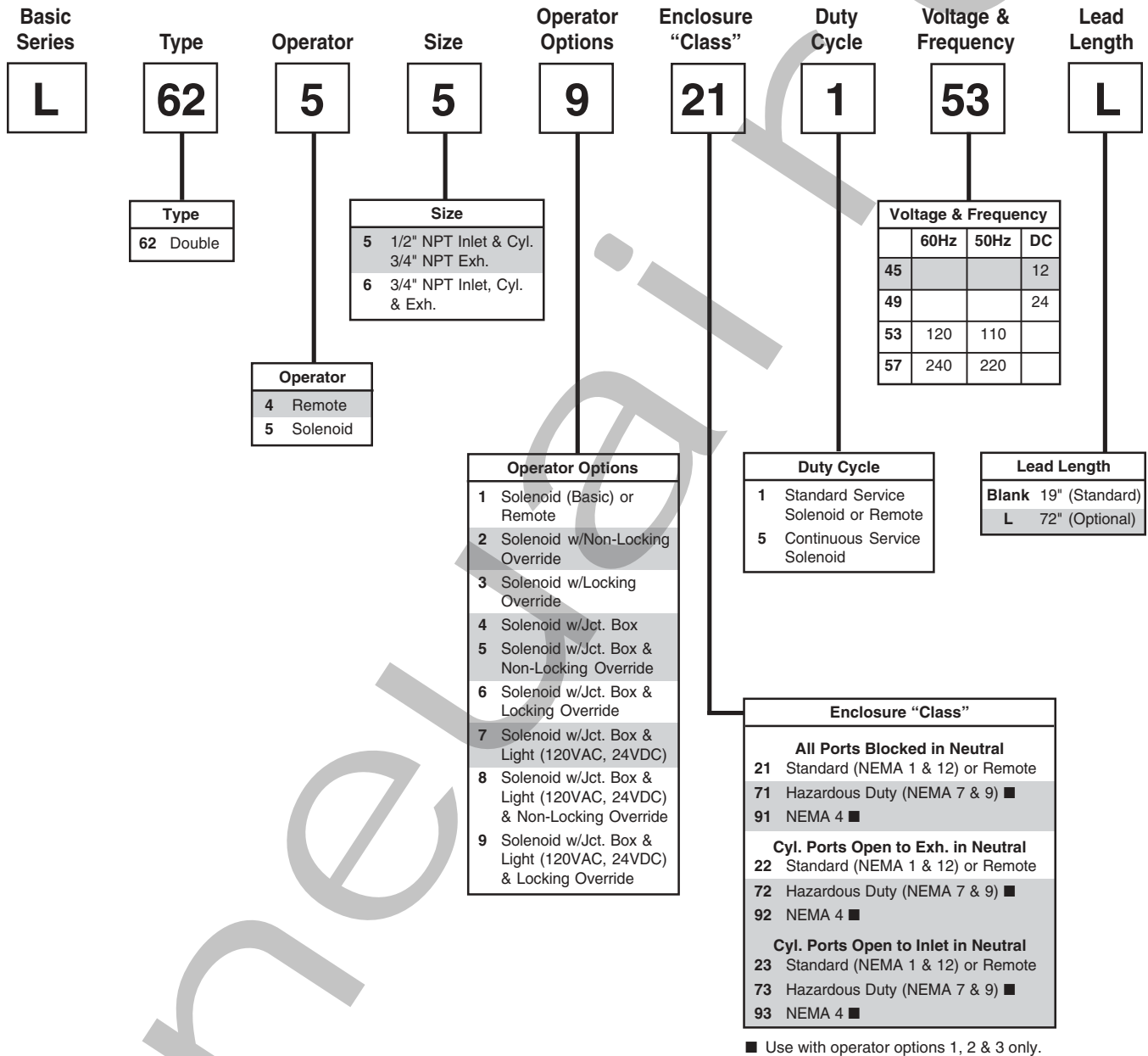

Note: Shaded options have been discontinued. Refer to back of Catalog for Cross Reference Information.

1/4" & 3/8" NPT Ports, Nominal Cv = 1.8

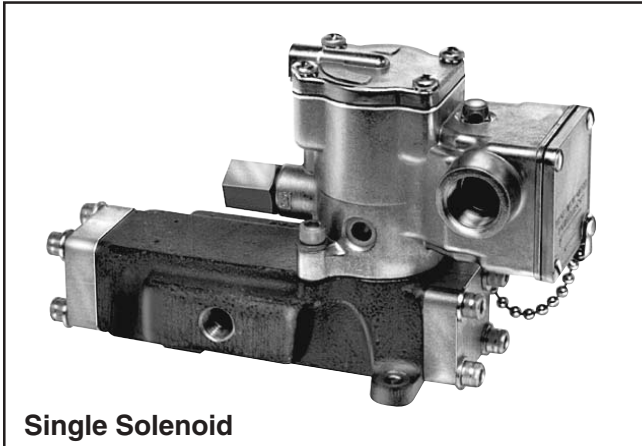

Single Solenoid

Application

These valves may be used to actuate a double acting cylinder. A maintained electrical signal shifts the valve. When this signal is removed the valve returns to its normal condition. For alternate flow path usages, see *Optional Functions* page.

Mounting

Valve may be mounted in any position.

Operation: Pressure Service

De-energized (normal condition) – Pressure at Port P is connected to “Cylinder” Port A. “Cylinder” Port B is connected to “Exhaust” Port E.

Energized (maintained signal applied) – Pressure at Port P is connected to “Cylinder” Port B, “Cylinder” Port A is connected to “Exhaust” Port E.

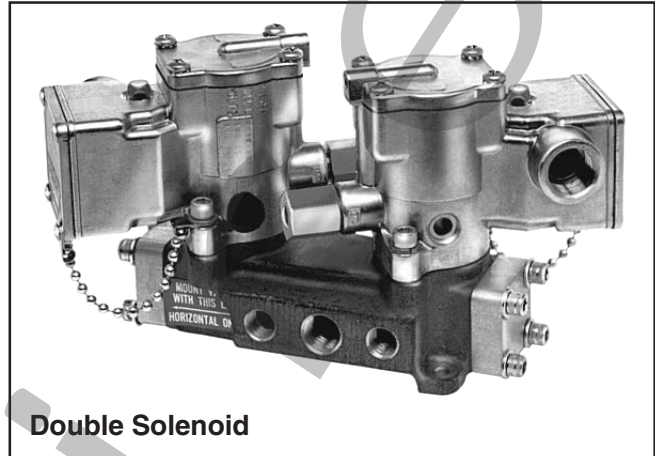
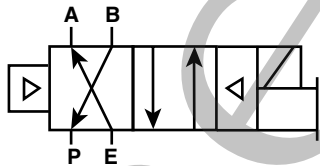

Double Solenoid

Application

These valves may be used to actuate double acting cylinders. A “momentary” electrical signal (exceeding .03 seconds) applied to one of the solenoids shifts the valve. It will remain in this position until a “momentary” signal is applied to the other solenoid. For alternative flow path usages, service, see *Optional Functions* page.

Mounting

Axis of main valve spool to be in horizontal plane.

Operation: Pressure Service

With solenoid “A” having been energized last – Pressure at Port P is connected to “Cylinder” Port A. “Cylinder” Port B is connected to “Exhaust” Port E.

Energize solenoid “B” – Pressure at Port P is connected to “Cylinder” Port B. “Cylinder” Port A is connected to “Exhaust” Port E.

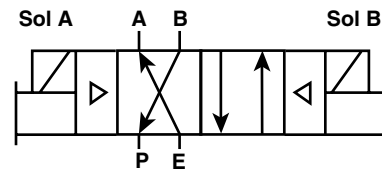

Model Selection

Valve		Voltage	Port Size (NPT)		Operator Type
Single Solenoid	Double Solenoid		P, A & B	Exhaust	
L485 29 102 53	L465 29 102 53	120V 60Hz 110V 50Hz	1/4"	3/8"	Junction Box
L485 39 102 53	L465 39 102 53		3/8"	3/8"	
L485 26 102 **	L465 26 102 **	Other	1/4"	3/8"	Junction Box
L485 36 102 **	L465 36 102 **		3/8"	3/8"	
L485 23 102 **	L465 23 102 **	Any	1/4"	3/8"	Basic
L485 33 102 **	L465 33 102 **		3/8"	3/8"	
L485 23 802 **	L465 23 802 **	Any	1/4"	3/8"	NEMA 4
L485 33 802 **	L465 33 802 **		3/8"	3/8"	
L485 23 602 **	L465 23 602 **	See Voltage Chart	1/4"	3/8"	▲ Hazardous Duty
L485 33 602 **	L465 33 602 **		3/8"	3/8"	

See page 45 for variations and (**) voltage codes.

Note: Shaded areas are no longer available.

▲ - UL & CSA Approved.

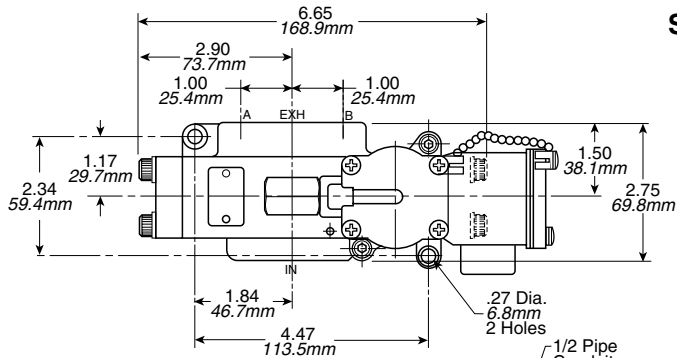

Single Solenoid

Parts List

Item No.	Part No.	Description
2	K18R311093	Retaining Ring
3	K453 006	Spacer
* 4	—	O-Ring
5	K453 005	Spacer
* 6	—	Seal
7	K232 018	Spool Assy.
* 8	—	Seal
*11	—	Gasket
13	H175 12	Lockwasher
14	H100 60	Cap Screw
18	K152 003	Override Assy.
21	K983 001	Shock Pad

* Standard Service Kit: K352 150
 * Special Service Kit: K352 350 (Continuous Duty)

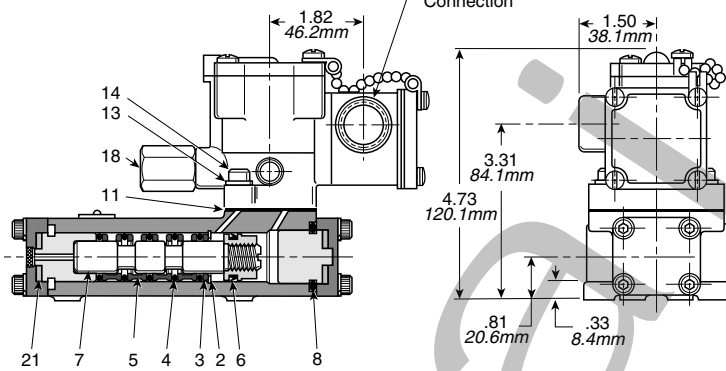

Double Solenoid

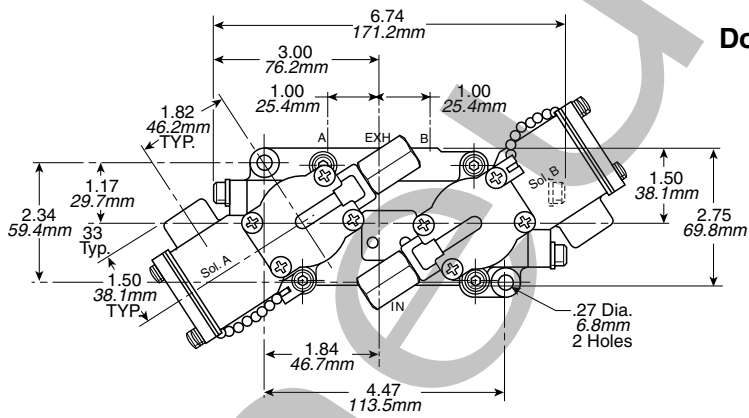

Parts List

Item No.	Part No.	Description
* 2	—	O-Ring
3	K453 005	Spacer
4	K493 005	Spool
* 5	—	Seal
* 8	—	Gasket
10	H175 12	Lockwasher
11	H100 60	Cap Screw
17	K152 003	Override Assy.
18	K983 001	Shock Pad

* Standard Service Kit: K352 151
 * Special Service Kit: K352 351 (Continuous Duty)

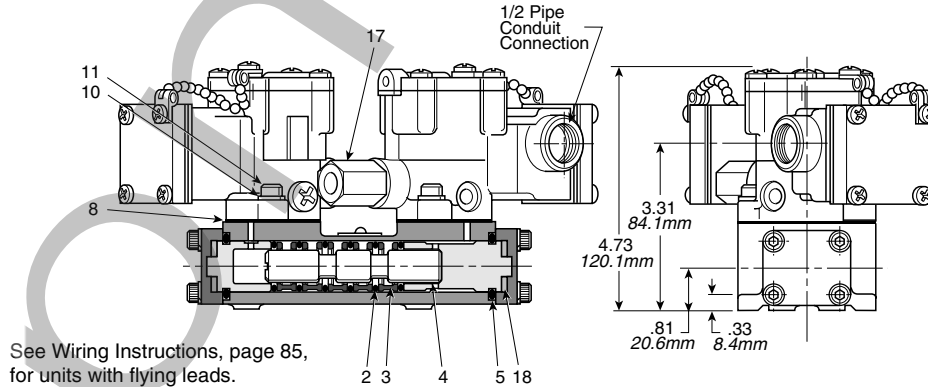

See Wiring Instructions, page 85, for units with flying leads.

3/8" & 1/2" NPT Ports, Nominal Cv = 4.8

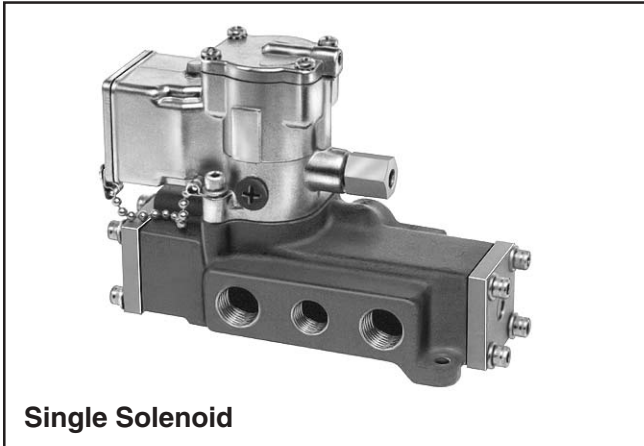

Single Solenoid

Application

These valves may be used to actuate a double acting cylinder. A maintained electrical signal shifts the valve. When this signal is removed the valve returns to its normal condition. For alternate flow path usages, such as dual pressure service, see *Optional Functions* page.

Mounting

Valve may be mounted in any position.

Operation: Pressure Service

De-energized (normal condition) – Pressure at Port P is connected to “Cylinder” Port A. “Cylinder” Port B is connected to “Exhaust” Port EB.

Energized (maintained signal applied) – Pressure at Port P is connected to “Cylinder” Port B, “Cylinder” Port A is connected to “Exhaust” Port EA.

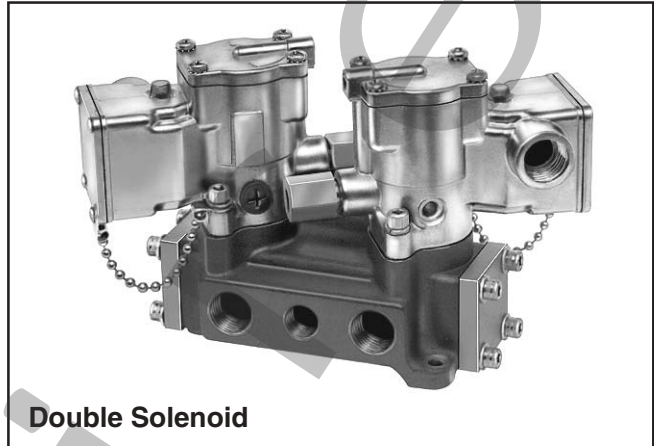
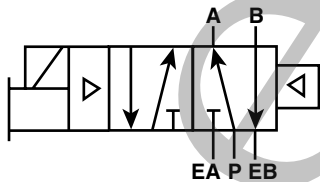

Double Solenoid

Application

These valves may be used to actuate double acting cylinders. A “momentary” electrical signal (exceeding .03 seconds) applied to one of the solenoids shifts the valve. It will remain in this position until a “momentary” signal is applied to the other solenoid. For alternative flow path usages, such as dual pressure service, see *Optional Functions* page.

Mounting

Axis of main valve spool to be in horizontal plane.

Operation: Pressure Service

With solenoid “A” (solenoid nearest Port B on valve body) having been energized last – Pressure at Port P is connected to “Cylinder” Port A. “Cylinder” Port B is connected to “Exhaust” Port EB.

Energize solenoid “B” (solenoid nearest Port A on valve body) – Pressure at Port P is connected to “Cylinder” Port B. “Cylinder” Port A is connected to “Exhaust” Port EA.

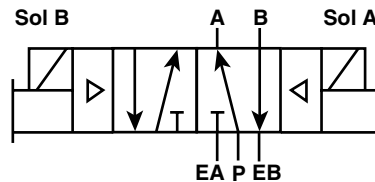

Model Selection

Valve		Voltage	Port Size (NPT)		Operator Type
Single Solenoid	Double Solenoid		P, A & B	EA & EB	
L705 39 102 53	L685 39 102 53	120V 60Hz 110V 50Hz	3/8"	1/2"	Junction Box
L705 49 102 53	L685 49 102 53		1/2"	1/2"	
L705 36 102 **	L685 36 102 **	Other	3/8"	1/2"	Junction Box
L705 46 102 **	L685 46 102 **		1/2"	1/2"	
L705 33 102 **	L685 33 102 **	Any	3/8"	1/2"	Basic
L705 43 102 **	L685 43 102 **		1/2"	1/2"	
L705 33 802 **	L685 33 802 **	Any	3/8"	1/2"	NEMA 4
L705 43 802 **	L685 43 802 **		1/2"	1/2"	
L705 33 602 **	L685 33 602 **	See Voltage Chart	3/8"	1/2"	▲ Hazardous Duty
L705 43 602 **	L685 43 602 **		1/2"	1/2"	

See page 45 for variations and (**) voltage codes.

▲ - UL & CSA Approved.

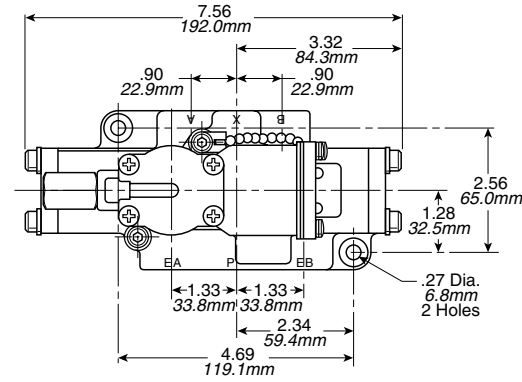

Single Solenoid

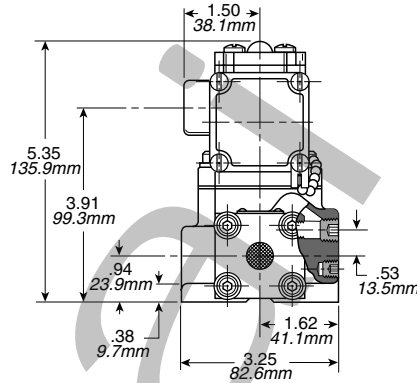
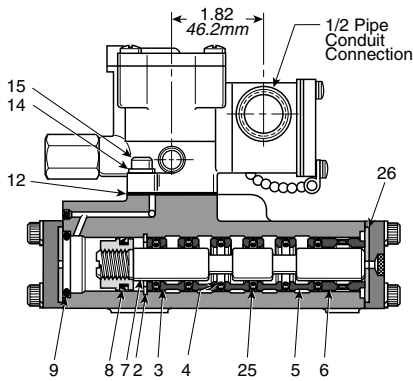

Parts List

Item No.	Part No.	Description
2	H090 71	Retaining Ring
3	K463 015	Spacer
* 4	—	O-Ring (Dynamic)
5	K453 028	Spacer
6	K463 012	End Spacer
7	K232 020	Spool Assy.
* 8	—	Seal
* 9	—	Seal
*12	—	Gasket
14	H175 12	Lockwasher
15	H100 60	Cap Screw
22	K152 003	Override Assy.
*25	—	O-Ring (Static)
26	K983 002	Shock Pad

* Standard Service Kit: K352 124
 * Special Service Kit: K352 125 (Continuous Duty)

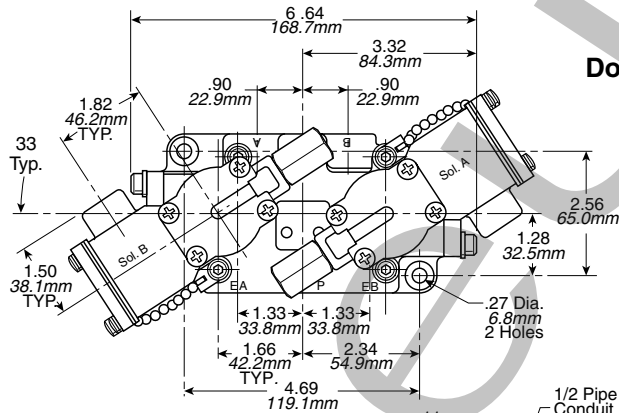

Double Solenoid

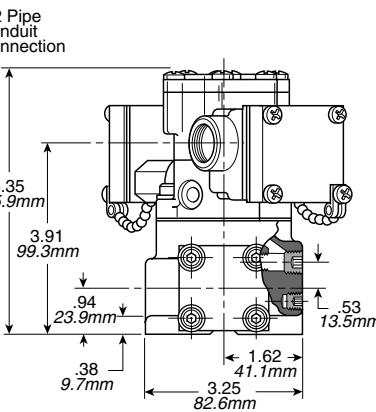
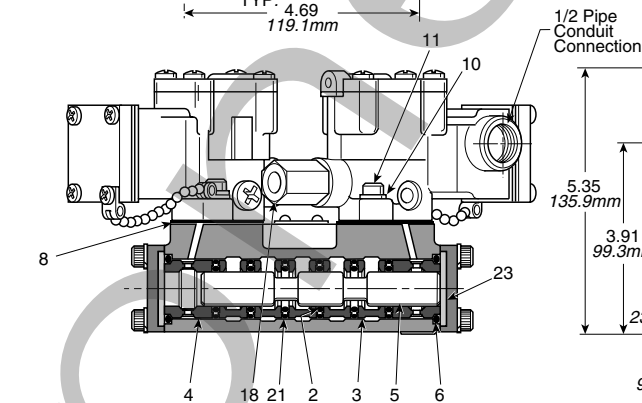

Parts List

Item No.	Part No.	Description
* 2	—	O-Ring (Dynamic)
3	K453 028	Spacer
4	K463 012	End Spacer
5	K343 094	Spool
* 6	—	Seal
* 8	—	Gasket
10	H175 12	Lockwasher
11	H100 60	Cap Screw
18	K152 003	Override Assy.
*21	—	O-Ring (Static)
23	K983 002	Shock Pad

* Standard Service Kit: K352 126
 * Special Service Kit: K352 127 (Continuous Duty)

See Wiring Instructions, page 85, for units with flying leads

1/2" & 3/4" NPT Ports, Nominal Cv = 5.5

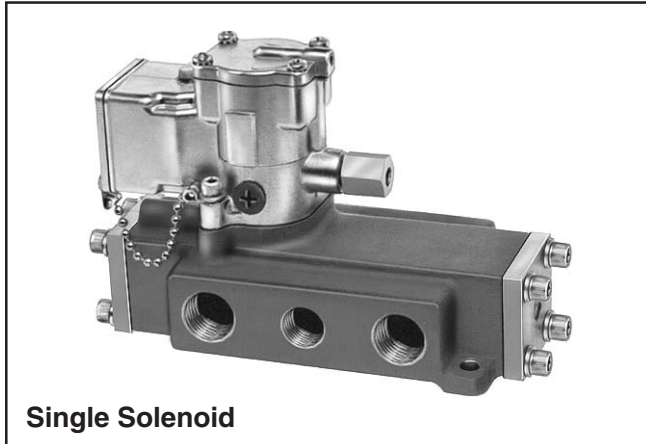

Single Solenoid

Application

These valves may be used to actuate a double acting cylinder. A maintained electrical signal shifts the valve. When this signal is removed the valve returns to its normal condition. For alternate flow path usages, such as dual pressure service, see *Optional Functions* page.

Mounting

Valve may be mounted in any position.

Operation: Pressure Service

De-energized (normal condition) – Pressure at Port P is connected to “Cylinder” Port A. “Cylinder” Port B is connected to “Exhaust” Port EB.

Energized (maintained signal applied) – Pressure at Port P is connected to “Cylinder” Port B, “Cylinder” Port A is connected to “Exhaust” Port EA.

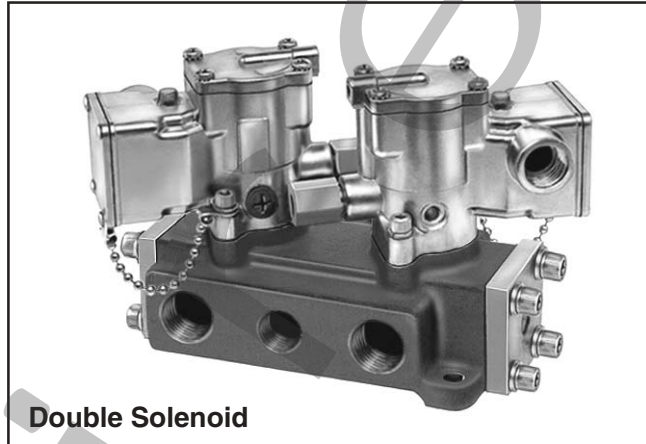
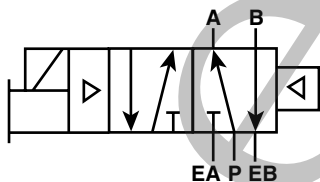

Double Solenoid

Application

These valves may be used to actuate double acting cylinders. A “momentary” electrical signal (exceeding .03 seconds) applied to one of the solenoids shifts the valve. It will remain in this position until a “momentary” signal is applied to the other solenoid. For alternative flow path usages, such as dual pressure service, see *Optional Functions* page.

Mounting

Axis of main valve spool to be in horizontal plane.

Operation: Pressure Service

With solenoid “A” (solenoid nearest Port B on valve body) having been energized last – Pressure at Port P is connected to “Cylinder” Port A. “Cylinder” Port B is connected to “Exhaust” Port EB.

Energize solenoid “B” (solenoid nearest Port A on valve body) – Pressure at Port P is connected to “Cylinder” Port B. “Cylinder” Port A is connected to “Exhaust” Port EA.

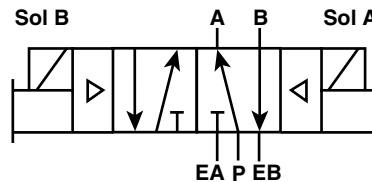

Model Selection

Valve		Voltage	Port Size (NPT)		Operator Type
Single Solenoid	Double Solenoid		P, A & B	EA & EB	
L645 59 102 53	L615 59 102 53	120V 60Hz 110V 50Hz	1/2"	3/4"	Junction Box
L645 69 102 53	L615 69 102 53		3/4"	3/4"	
L645 56 102 **	L615 56 102 **	Other	1/2"	3/4"	Junction Box
L645 66 102 **	L615 66 102 **		3/4"	3/4"	
L645 53 102 **	L615 53 102 **	Any	1/2"	3/4"	Basic
L645 63 102 **	L615 63 102 **		3/4"	3/4"	
L645 53 802 **	L615 53 802 **	Any	1/2"	3/4"	NEMA 4
L645 63 802 **	L615 63 802 **		3/4"	3/4"	
L645 53 602 **	L615 53 602 **	See Voltage Chart	1/2"	3/4"	▲ Hazardous Duty
L645 63 602 **	L615 63 602 **		3/4"	3/4"	

See page 46 for variations and (**) voltage codes.

Note: Shaded areas are no longer available.

▲ - UL & CSA Approved.

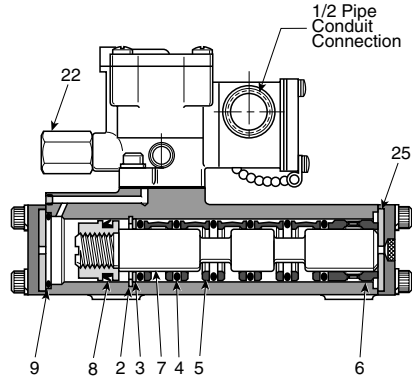
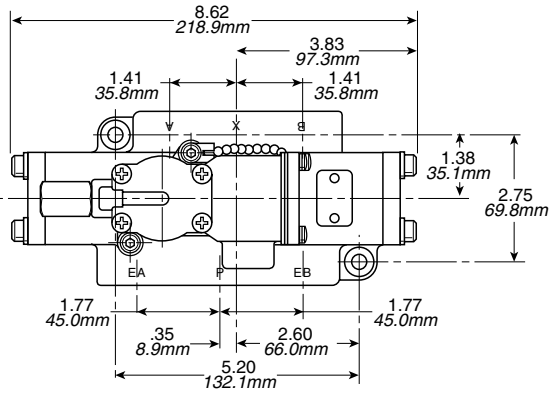

Single Solenoid

Parts List

Item No.	Part No.	Description
2	K18R311137	Retaining Ring
3	K553 011	Washer
* 4	—	O-Ring
5	K453 008	Spacer
6	K463 001	End Spacer
7	K232 017	Spool Assy.
* 8	—	Seal
* 9	—	Seal
*12	—	Gasket
14	H175 12	Lockwasher
15	H100 60	Cap Screw
22	K152 003	Override Assy.
25	K983 003	Shock Pad

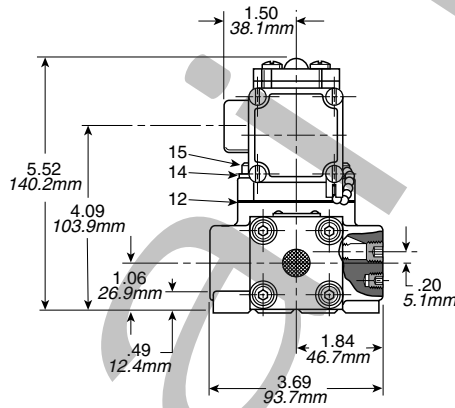

* Standard Service Kit: K352 152

* Special Service Kit: K352 352 (Continuous Duty)

Double Solenoid

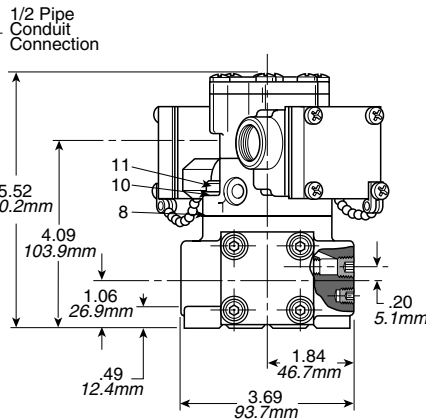
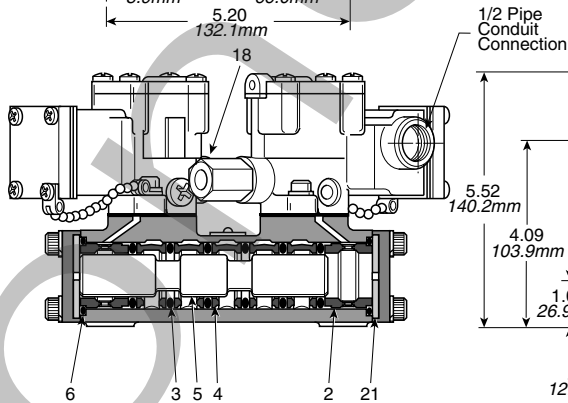
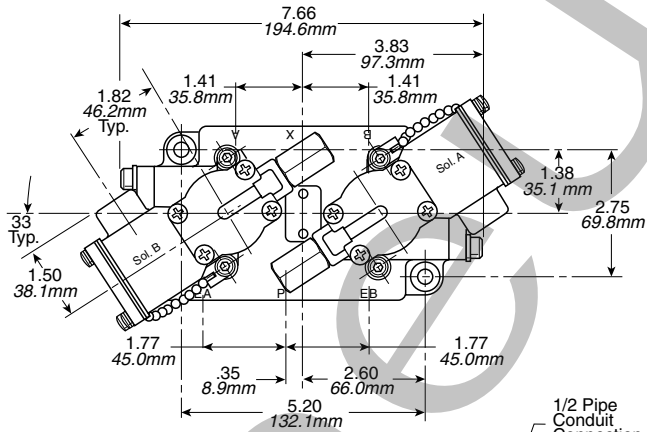

Parts List

Item No.	Part No.	Description
2	K463 001	End Spacer
* 3	—	O-Ring
4	K453 008	Spacer
5	K343 046	Spool
* 6	—	Seal
* 8	—	Gasket
10	H175 12	Lockwasher
11	H100 60	Cap Screw
18	K152 003	Override Assy.
21	K983 003	Shock Pad

* Standard Service Kit: K352 153

* Special Service Kit: K352 353 (Continuous Duty)

See Wiring Instructions, page 85, for units with flying leads.

3/4", 1" & 1-1/4" NPT Ports, Nominal Cv = 12.0



Single Solenoid

Application

These valves may be used to actuate a double acting cylinder. A maintained electrical signal shifts the valve. When this signal is removed the valve returns to its normal condition. For alternate flow path usages, such as dual pressure service, see *Optional Functions* page.

Mounting

Valve may be mounted in any position.

Operation: Pressure Service

De-energized (normal condition) – Pressure at Port P is connected to “Cylinder” Port A. “Cylinder” Port B is connected to “Exhaust” Port EB.

Energized (maintained signal applied) – Pressure at Port P is connected to “Cylinder” Port B, “Cylinder” Port A is connected to “Exhaust” Port EA.

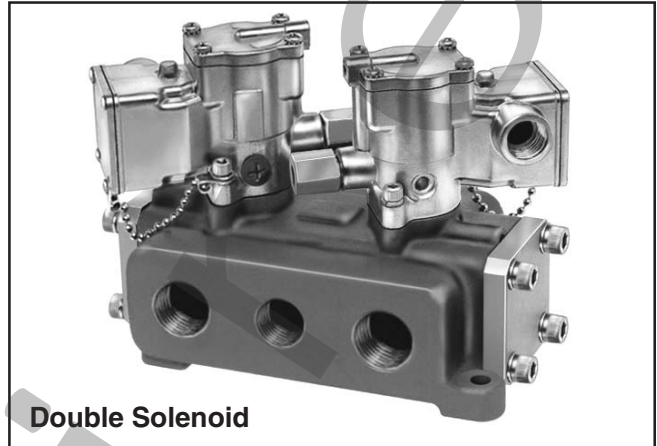
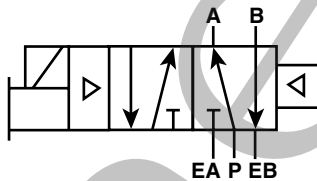

Double Solenoid

Application

These valves may be used to actuate double acting cylinders. A “momentary” electrical signal (exceeding .03 seconds) applied to one of the solenoids shifts the valve. It will remain in this position until a “momentary” signal is applied to the other solenoid. For alternative flow path usages, such as dual pressure service, see *Optional Functions* page.

Mounting

Axis of main valve spool to be in horizontal plane.

Operation: Pressure Service

With solenoid “A” (solenoid nearest Port B on valve body) having been energized last – Pressure at Port P is connected to “Cylinder” Port A. “Cylinder” Port B is connected to “Exhaust” Port EB.

Energize solenoid “B” (solenoid nearest Port A on valve body) – Pressure at Port P is connected to “Cylinder” Port B. “Cylinder” Port A is connected to “Exhaust” Port EA.

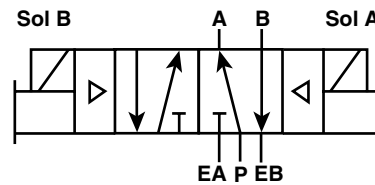

Model Selection

Valve		Voltage	Port Size (NPT)		Type
Single Solenoid	Double Solenoid		P, A & B	EA & EB	
L705 79 102 53	L685 79 102 53	110V 50Hz	3/4"	1"	Junction Box
L705 89 102 53	L685 89 102 53		1"	1-1/4"	
L705 99 102 53	L685 99 102 53		1-1/4"	1-1/4"	
L705 76 102 **	L685 76 102 **		3/4"	1"	
L705 86 102 **	L685 86 102 **	Other	1"	1-1/4"	Junction Box
L705 96 102 **	L685 96 102 **		1-1/4"	1-1/4"	
L705 73 602 **	L685 73 602 **	See Voltage Chart	3/4"	1"	▲ Hazardous Duty
L705 83 602 **	L685 83 602 **		1"	1-1/4"	
L705 93 602 **	L685 93 602 **		1-1/4"	1-1/4"	

See page 45 for variations and (**) voltage codes.

▲ - UL & CSA Approved.

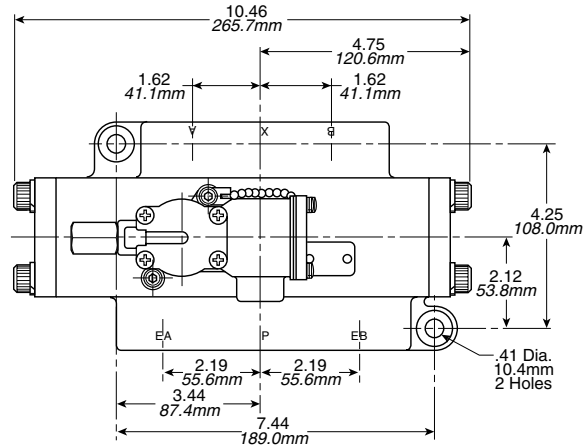

Single Solenoid

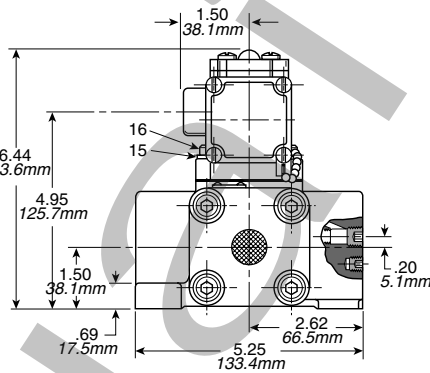
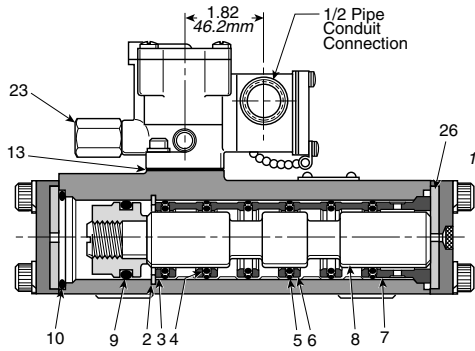

Parts List

Item No.	Part No.	Description
2	H090 09	Retaining Ring
3	K553 009	Spacer
* 4	—	O-Ring (Dynamic)
* 5	—	O-Ring (Static)
6	K453 009	Spacer
7	K463 005	End Spacer
8	K232 014	Spool Assy.
* 9	—	O-Ring
*10	—	Seal
*13	—	Gasket
15	H175 12	Lockwasher
16	H100 60	Cap Screw
23	K152 003	Override Assy.
26	K983 004	Shock Pad

* Standard Service Kit: K352 128
 * Special Service Kit: K352 129 (Continuous Duty)

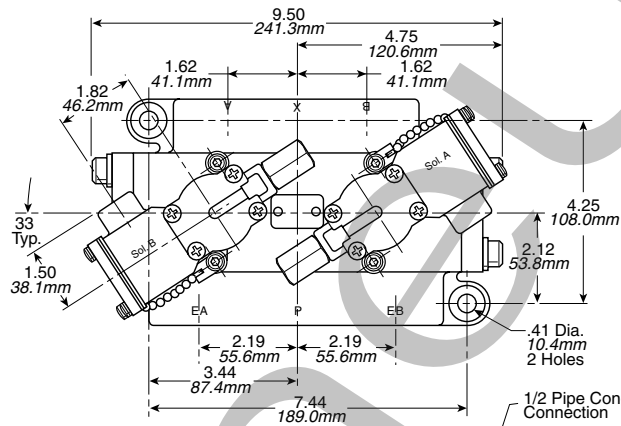

Double Solenoid

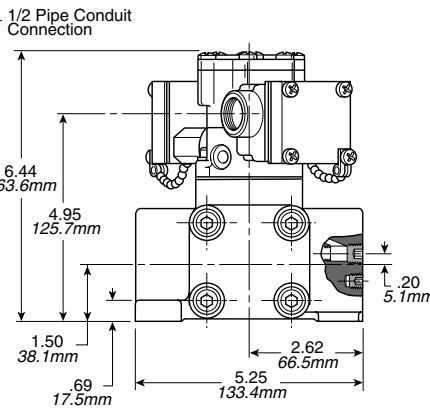
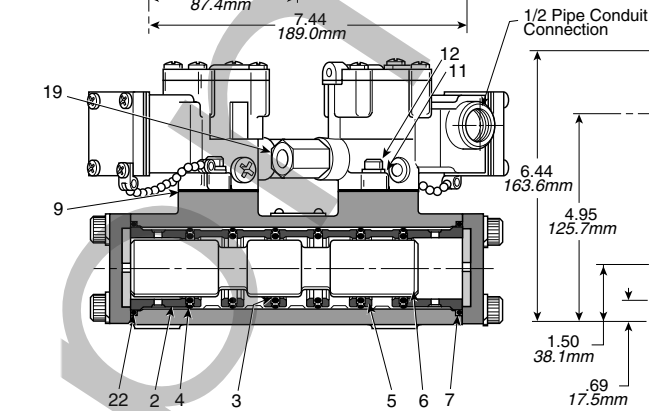

Parts List

Item No.	Part No.	Description
2	K463 005	End Spacer
* 3	—	O-Ring (Dynamic)
* 4	—	O-Ring (Static)
5	K453 009	Spacer
6	K343 061	Spool
* 7	—	Seal
* 9	—	Gasket
11	H175 12	Lockwasher
12	H100 60	Cap Screw
19	K152 003	Override Assy.
22	K983 004	Shock Pad

* Standard Service Kit: K352 130
 * Special Service Kit: K352 131 (Continuous Duty)

See Wiring Instructions, page 85, for units with flying leads.

1/4" & 3/8" NPT Ports, Nominal Cv = 1.8

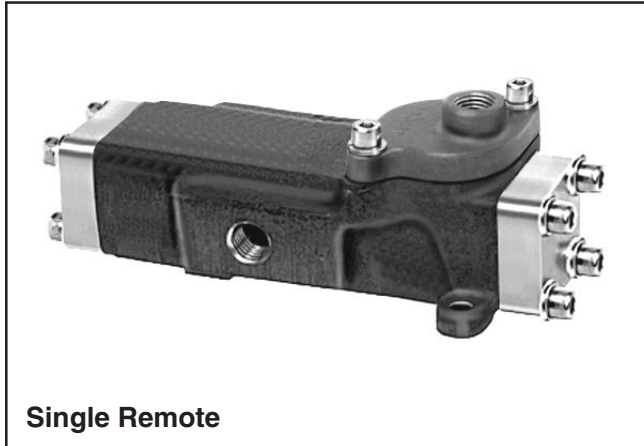

Single Remote

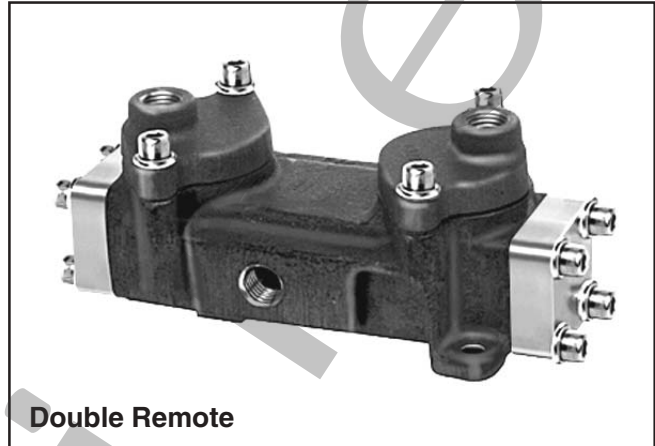

Double Remote

Application

These valves may be used to activate double acting cylinders. A maintained pressure signal to the pilot cap activates the valve. When this signal is removed, the valve shifts. For alternate flow path usages, see *Optional Functions* page.

Mounting

Valve may be mounted in any position.

Operation: Pressure Service

Pressure to pilot cap – Port P is connected to “Cylinder” Port A. “Cylinder” Port B is connected to “Exhaust” Port E.

When pressure to pilot is removed – Pressure at Port P is connected to “Cylinder” Port B. “Cylinder” Port A is connected to “Exhaust” Port E.

Application

These valves may be used to activate double acting cylinders. A momentary pressure signal applied alternately to each of the pilot caps shifts the valve. For alternate flow path usages, see *Optional Functions* page.

Mounting

Axis of main valve spool is in horizontal plane.

Operation: Pressure Service

Pilot “A” pressurized last – Pressure at Port P is connected to “Cylinder” Port B. “Cylinder” Port A is connected to “Exhaust” Port E.

Pilot “B” pressurized last – Pressure at Port P is connected to “Cylinder” Port A. “Cylinder” Port B is connected to “Exhaust” Port E.

DISCONTINUED

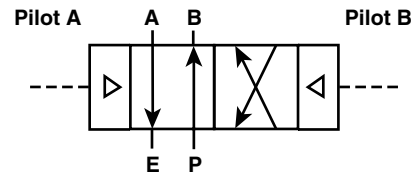
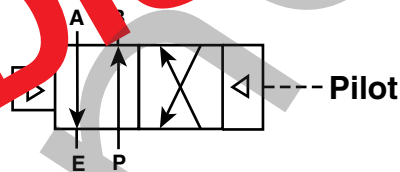

Model Selection

Note: Shaded units are no longer available.

Valve		Port Size (NPT)	
Single Remote	Double Remote	P, A & B	Exhaust
L484 21 102	L464 21 102	1/4"	3/8"
L484 31 102	L464 31 102	3/8"	3/8"

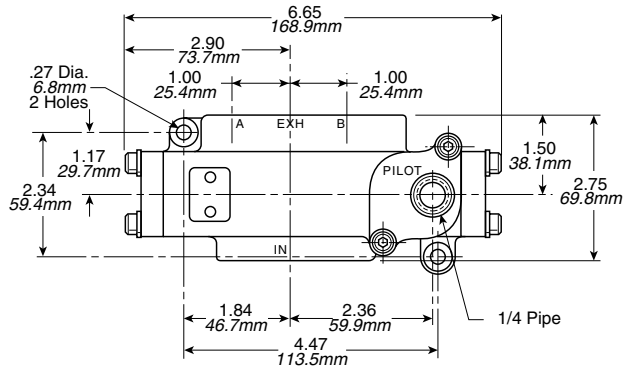

Single Remote

Parts List

Item No.	Part No.	Description
2	K18R311093	Retaining Ring
3	K453 006	Spacer
* 4	—	O-Ring
5	K453 005	Spacer
* 6	—	Seal
7	K232 018	Spool Assy.
* 8	—	Seal
9	K323 027	Remote Cap
*10	—	Gasket
11	H175 12	Lockwasher
12	H100 60	Cap Screw
13	K983 001	Shock Pad

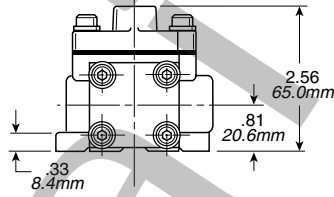
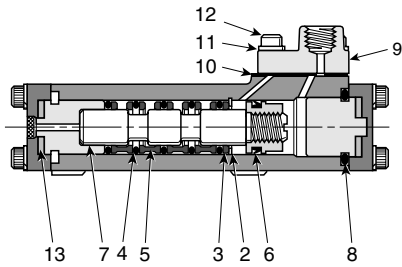

* Standard Service Kit: K352 363

Double Remote

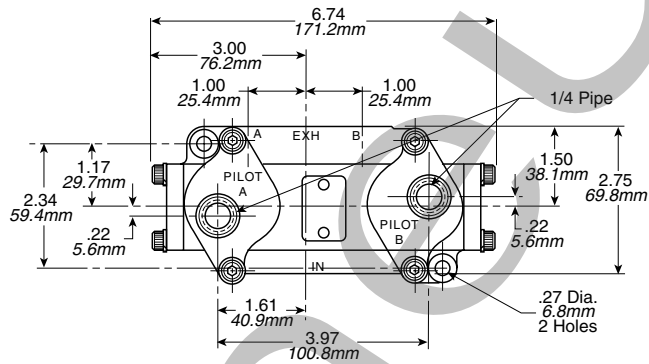

Parts List

Item No.	Part No.	Description
* 2	—	O-Ring
3	K453 005	Spacer
4	K493 005	Spool
* 5	—	Seal
6	K323 027	Remote Cap
7	H100 60	Cap Screw
8	H175 12	Lockwasher
* 9	—	Gasket
10	K983 001	Shock Pad

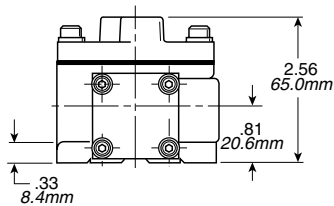
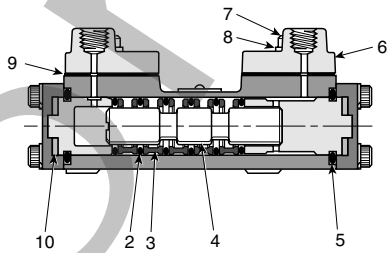

* Standard Service Kit: K352 357

3/8" & 1/2" NPT Ports, Nominal Cv = 4.8

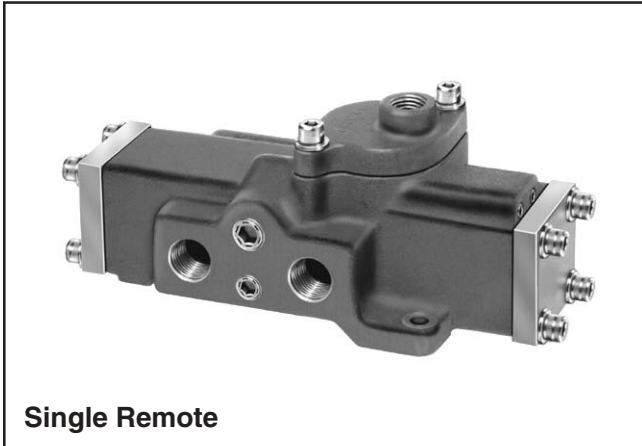

Single Remote

Application

These valves may be used to activate double acting cylinders. A maintained pressure signal to the pilot cap activates the valve. When this signal is removed, the valve shifts. For alternate flow path usages, see *Optional Functions* page.

Mounting

Valve may be mounted in any position.

Operation: Pressure Service

Pressure to pilot cap – Port P is connected to “Cylinder” Port A. “Cylinder” Port B is connected to “Exhaust” Port EB.

When pressure to pilot is removed – Pressure at Port P is connected to “Cylinder” Port B. “Cylinder” Port A is connected to “Exhaust” Port EA.

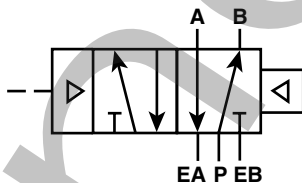

Double Remote

Application

These valves may be used to activate double acting cylinders. A momentary pressure signal applied alternately to each of the pilot caps shifts the valve. For alternate flow path usages, see *Optional Functions* page.

Mounting

Axis of main valve spool to be in horizontal plane.

Operation: Pressure Service

Pilot “A” (nearest Port B on valve body) pressurized last – Pressure at Port P is connected to “Cylinder” Port B. “Cylinder” Port A is connected to “Exhaust” Port EA.

Pilot “B” (nearest Port A on valve body) pressurized last – Pressure at Port P is connected to “Cylinder” Port A. “Cylinder” Port B is connected to “Exhaust” Port EB.

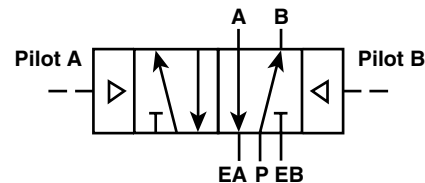

Model Selection

Valve		Port Size (NPT)	
Single Remote	Double Remote	P, A & B	EA & EB
L704 31 102	L684 31 102	3/8"	1/2"
L704 41 102	L684 41 102	1/2"	1/2"

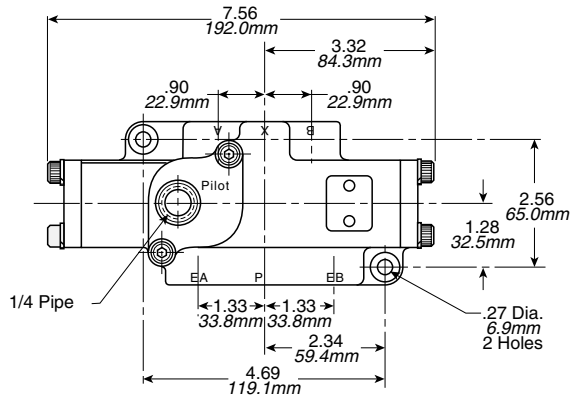

Single Remote

Parts List

Item No.	Part No.	Description
2	H090 71	Retaining Ring
3	K463 015	Spacer
* 4	—	O-Ring (Dynamic)
5	K453 028	Spacer
6	K463 012	End Spacer
7	K232 020	Spool Assy.
* 8	—	Seal
* 9	—	Seal
*10	—	O-Ring (Static)
11	K323 027	Remote Cap
*12	—	Gasket
13	H175 12	Lockwasher
14	H100 60	Cap Screw
15	K983 002	Shock Pad

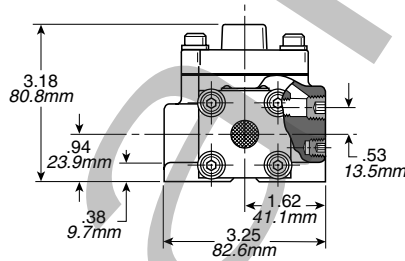
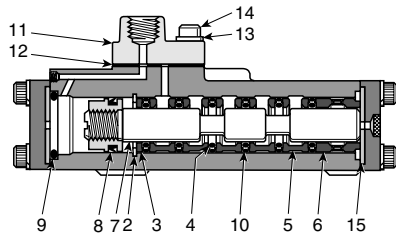

* Standard Service Kit: K352 362

Double Remote

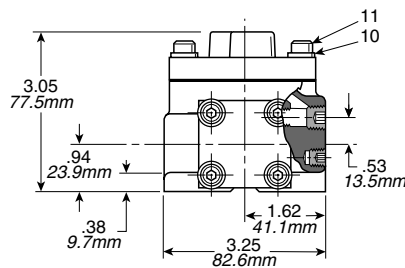
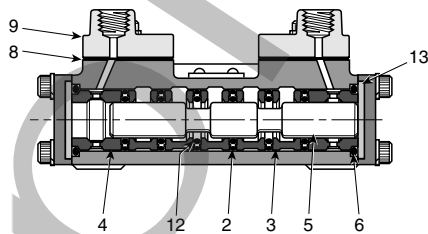
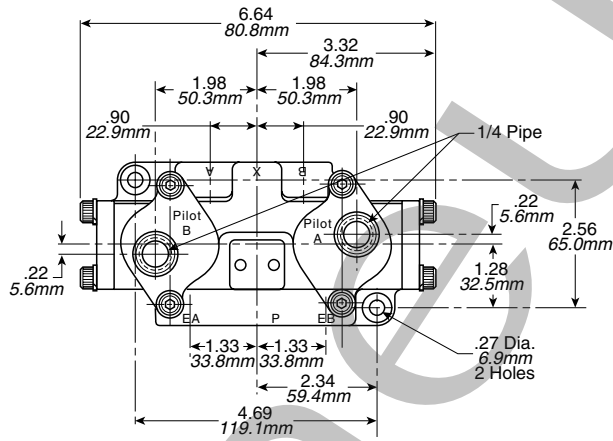

Parts List

Item No.	Part No.	Description
* 2	—	O-Ring (Static)
3	K453 028	Spacer
4	K463 012	End Spacer
5	K343 094	Spool
* 6	—	Seal
* 8	—	Gasket
9	K323 027	Remote Cap
10	H175 12	Lockwasher
11	H100 60	Cap Screw
*12	—	O-Ring (Dynamic)
13	K983 002	Shock Pad

* Standard Service Kit: K352 355

1/2" & 3/4" NPT Ports, Nominal Cv = 5.2

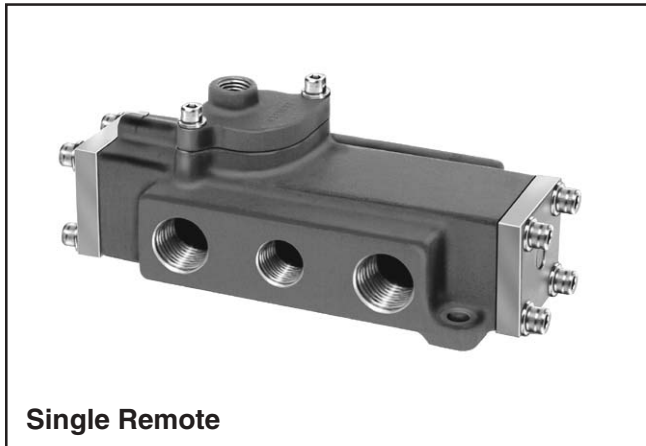

Single Remote

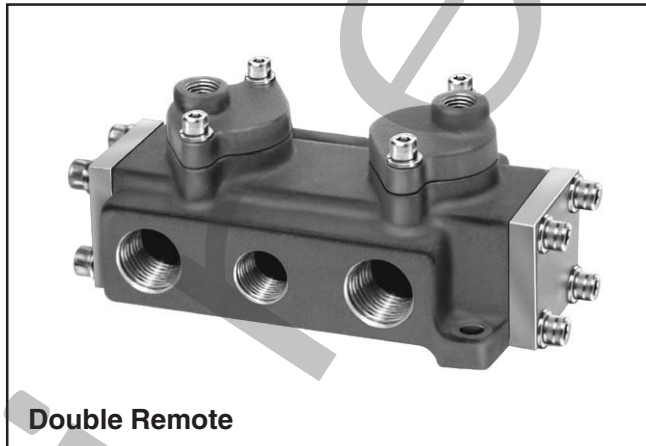

Double Remote

Application

These valves may be used to activate double acting cylinders. A maintained pressure signal to the pilot cap activates the valve. When this signal is removed, the valve shifts. For alternate flow path usages, see *Optional Functions* page.

Mounting

Valve may be mounted in any position.

Operation: Pressure Service

Pressure to pilot cap – Port P is connected to “Cylinder” Port A. “Cylinder” Port B is connected to “Exhaust” Port EB.

When pressure to pilot is removed – Pressure at port P is connected to “Cylinder” Port B. “Cylinder” Port A is connected to “Exhaust” Port EA.

Application

These valves may be used to activate double acting cylinders. A momentary pressure signal applied alternately to each of the pilot caps shifts the valve. For alternate flow path usages, see *Optional Functions* page.

Mounting

Axis of main valve spool is in the horizontal plane.

Operation: Pressure Service

Pilot “A” (nearest Port B on valve body) pressurized last – Pressure at Port P is connected to “Cylinder” Port B. “Cylinder” Port A is connected to “Exhaust” Port EA.

Pilot “B” (nearest Port A on valve body) pressurized last – Pressure at Port P is connected to “Cylinder” Port A. “Cylinder” Port B is connected to “Exhaust” Port EB.

DISCONTINUED

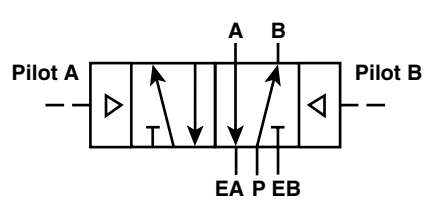

Model Selection

Note: Shaded units are no longer available.

Valve		Port Size (NPT)	
Single Remote	Double Remote	P, A & B	EA & EB
L644 51 102	L614 51 102	1/2"	3/4"
L644 61 102	L614 61 102	3/4"	3/4"

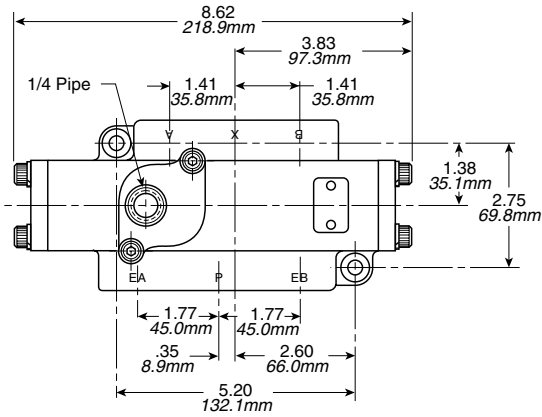

Single Remote

Parts List

Item No.	Part No.	Description
2	K18R311137	Retaining Ring
3	K553 011	Washer
* 4	—	O-Ring
5	K453 008	Spacer
6	K463 001	End Spacer
7	K232 017	Spool Assy.
* 8	—	Seal
* 9	—	Seal
*12	—	Gasket
13	H323 027	Remote Cap
14	H175 12	Lockwasher
15	H100 60	Cap Screw
16	K983 003	Shock Pad

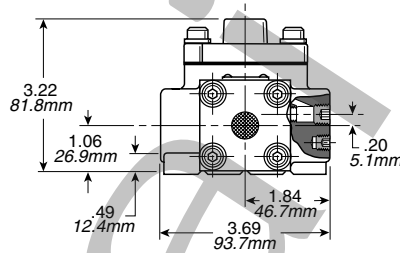
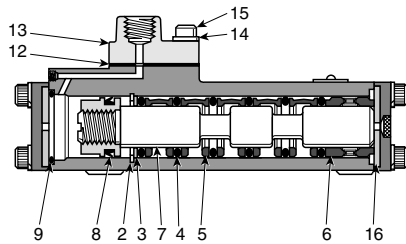

* Standard Service Kit: K352 361

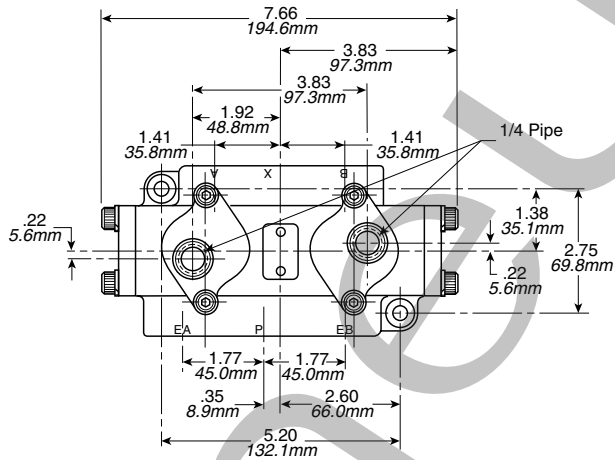

Double Remote

Parts List

Item No.	Part No.	Description
2	K463 001	End Spacer
* 3	—	O-Ring
4	K453 008	Spacer
5	K343 046	Spool
* 6	—	Seal
* 8	—	Gasket
9	K323 027	Remote Cap
10	H100 60	Cap Screw
11	H175 12	Lockwasher
13	K983 003	Shock Pad

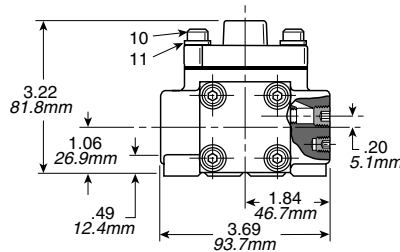
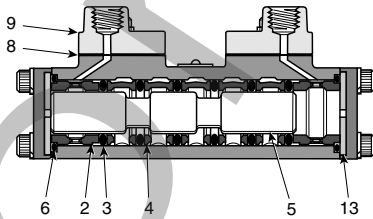

* Standard Service Kit: K352 358

3/4" Thru 1-1/4" NPT Ports, Nominal Cv = 12.0



Single Remote



Double Remote

Application

These valves may be used to activate double acting cylinders. A maintained pressure signal to the pilot cap activates the valve. When this signal is removed, the valve shifts. For alternate flow path usages, see *Optional Functions* page.

Mounting

Valve may be mounted in any position.

Operation: Pressure Service

Pressure to pilot cap – Port P is connected to “Cylinder” Port A. “Cylinder” Port B is connected to “Exhaust” Port EB.

When pressure to pilot is removed – Pressure at Port is connected to “Cylinder” Port B. “Cylinder” Port A is connected to “Exhaust” Port EA.

Application

These valves may be used to activate double acting cylinders. Normally open signals applied to the pilot caps are alternately bled off to actuate the valve. For alternate flow path usages, see *Optional Functions* page.

Mounting

Axis of main valve spool to be in horizontal plane.

Operation: Pressure Service

Pilot “A” (nearest Port B on valve body) pressurized last – Pressure at Port P is connected to “Cylinder” Port B. “Cylinder” Port A is connected to “Exhaust” Port EA.

Pilot “B” (nearest Port A on valve body) pressurized last – Pressure at Port P is connected to “Cylinder” Port A. “Cylinder” Port B is connected to “Exhaust” Port EB.

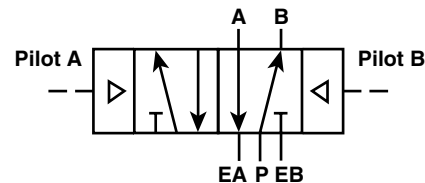
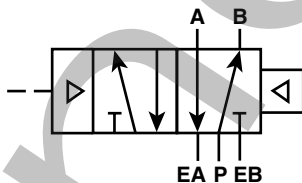

Model Selection

Valve		Port Size (NPT)	
Single Remote	Double Remote	P, A & B	EA & EB
L704 71 102	L684 71 102	3/4"	1"
L704 81 102	L684 81 102	1"	1-1/4"
L704 91 102	L684 91 102	1-1/4"	1-1/4"

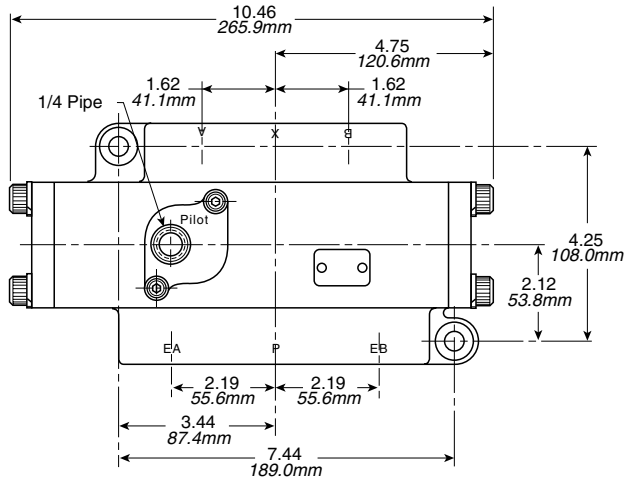

Single Remote

Parts List

Item No.	Part No.	Description
2	H090 09	Retaining Ring
3	K553 009	Spacer
* 4	—	O-Ring (Dynamic)
* 5	—	O-Ring (Static)
6	K453 009	Spacer
7	K463 005	End Spacer
8	K232 014	Spool Assy.
* 9	—	Seal
*10	—	O-Ring
*12	—	Gasket
13	K323 027	Remote Cap
14	H175 12	Lockwasher
15	H100 60	Cap Screw
16	K983 004	Shock Pad

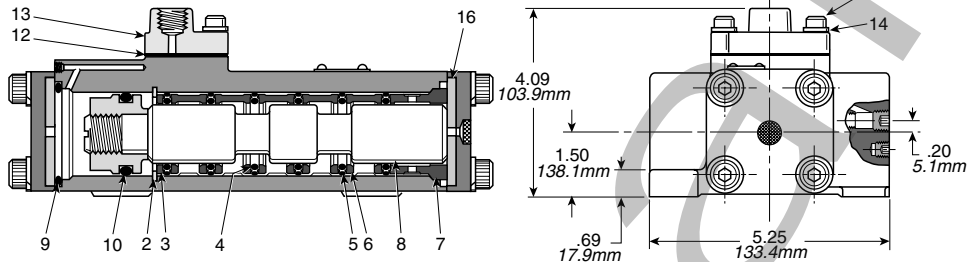

* Standard Service Kit: K352 359

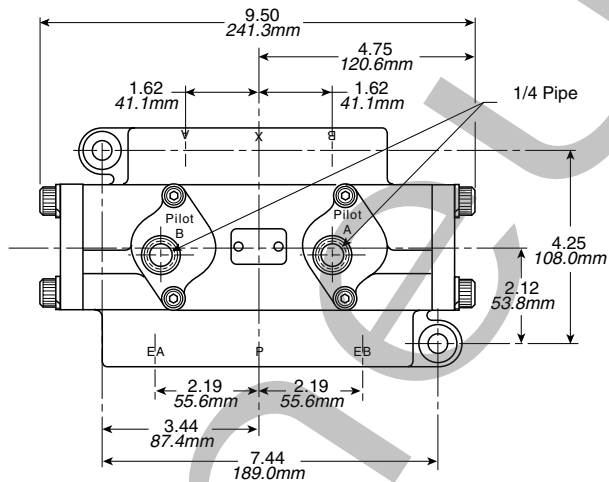

Double Remote

Parts List

Item No.	Part No.	Description
2	K463 005	End Spacer
* 3	—	O-Ring (Static)
* 4	—	O-Ring (Dynamic)
5	K453 009	Spacer
6	K343 061	Spool
* 7	—	Seal
* 9	—	Gasket
10	K323 027	Remote Cap
11	H175 12	Lockwasher
12	H100 60	Cap Screw
13	K983 004	Shock Pad

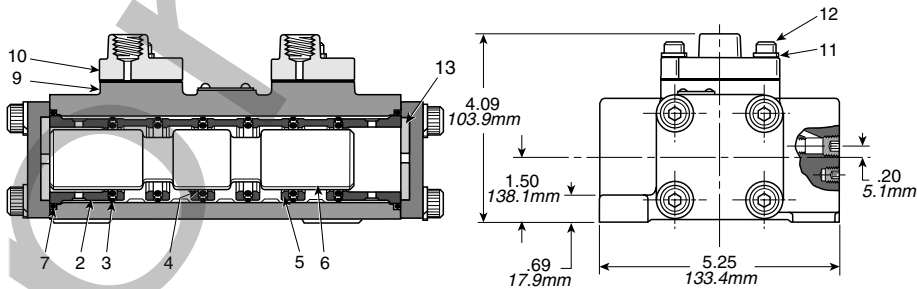

* Standard Service Kit: K352 360

4-Way, 4-Port, 3-Position & 4-Way, 5-Port, 3-Position - 1/4" Thru 3/4" NPT Ports

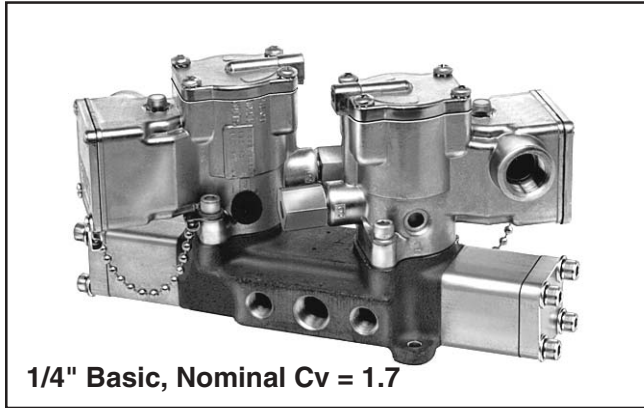

1/4" Basic, Nominal Cv = 1.7

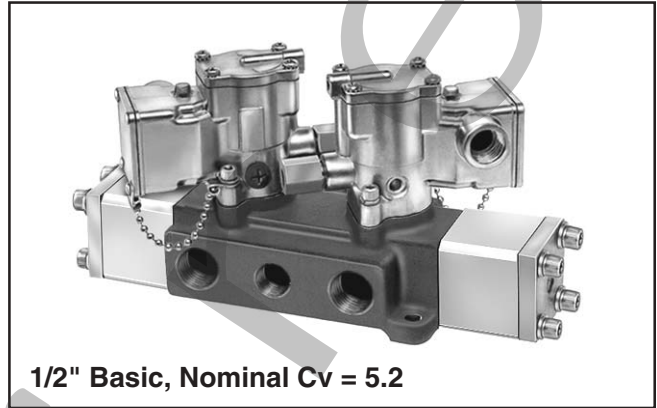

1/2" Basic, Nominal Cv = 5.2

Application

These valves may be used to actuate double acting cylinders, when "inching" or incremental rod movement is desired. A "momentary" (exceeding .03 seconds) or maintained electrical signal applied to one of the solenoids shifts the valve, the valve returns to the "neutral" condition when the electrical signal is removed. Valve may be applied for alternate service. For alternate flow path usages, see *Optional Functions* page.

Operation: Pressure Service

Neutral "Class 21"

Both solenoids de-energized (Normal Condition) – All ports blocked.

Neutral "Class 22" (L625 Only)

Both solenoids de-energized (Normal Condition) – "Cylinder" Port A is open to "Exhaust" Port E (EA), "Cylinder" Port B is open to "Exhaust" Port E (EB), "Pressure" Port P is blocked.

Neutral "Class 23"

Both solenoids de-energized (Normal Condition) – "Cylinder" Port A is open to Pressure Port P, "Cylinder" Port B is open to Pressure Port P. Both "Exhaust" Port(s) E (EA and EB) are blocked.

Activated Operation

With solenoid "A" energized – Pressure at Port P flows to "Cylinder" Port A, "Cylinder" Port B is connected to "Exhaust" Port E (EB).

With solenoid "B" energized – Pressure at Port P is connected to "Cylinder" Port B. "Cylinder" Port A is connected to "Exhaust" Port E (EA).

1/4" Basic

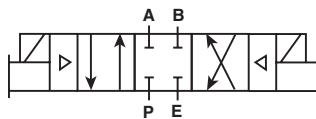

1/2" Basic

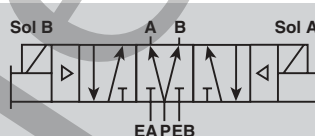
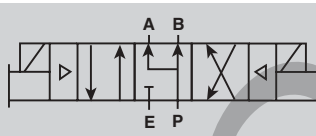
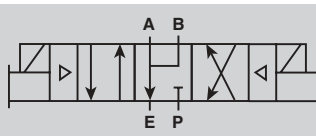
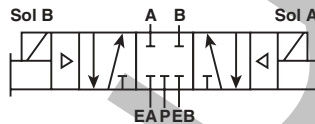

Model Selection (Neutral "Class 21" Shown)

Note: Shaded units are no longer available.

Valve		Voltage	Port Size (NPT)		Operator Type
1/4" Basic Size	1/2" Basic Size		P, A & B	Exhaust	
L475 29 211 53	—	120V 60Hz 110V 50Hz	1/4"	3/8"	Junction Box
L475 39 211 53	—		3/8"	3/8"	
—	L625 59 211 53		1/2"	3/4"	
—	L625 69 211 53		3/4"	3/4"	
L475 26 211 **	—	Other	1/4"	3/8"	Junction Box
L475 36 211 **	—		3/8"	3/8"	
—	L625 56 211 **		1/2"	3/4"	
—	L625 66 211 **		3/4"	3/4"	

See page 47 & 49 for variations in class of neutral configuration and (**) voltage codes.

Dimensional Data & Service Kits

L475 & L625, 1/4" & 1/2" Basic Valve

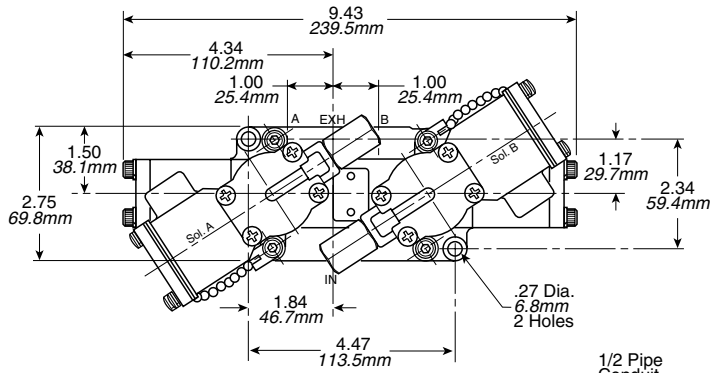

1/4" Basic

Parts List

Item No.	Part No.	Description
* 2	—	O-Ring
3	K453 005	Spacer
4	K343 020	Spool (All Ports Blocked)
4	K343 073	Spool (Cyl. Ports Open to Exhaust)
4	K343 021	Spool (Cyl. Ports Open to Inlet)
5	K313 009	Piston (Long)
6	K313 010	Piston (Short)
* 7	—	Seal
* 8	—	Seal
* 9	—	Seal
*15	—	Gasket
17	H175 12	Lockwasher
18	H100 60	Cap Screw
24	K152 003	Override Assy.

* Standard Service Kit: K352 151
 * Special Service Kit: K352 351 (Continuous Duty)

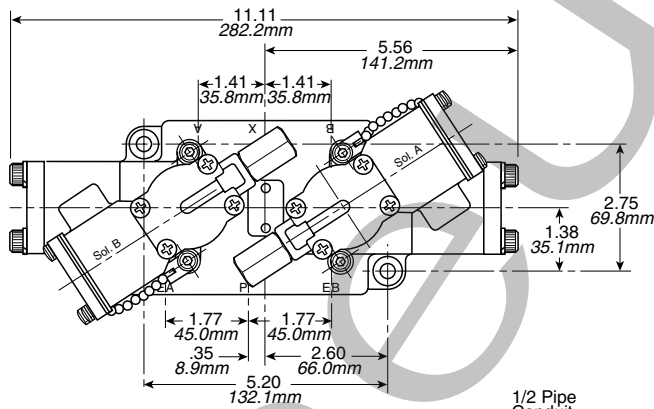
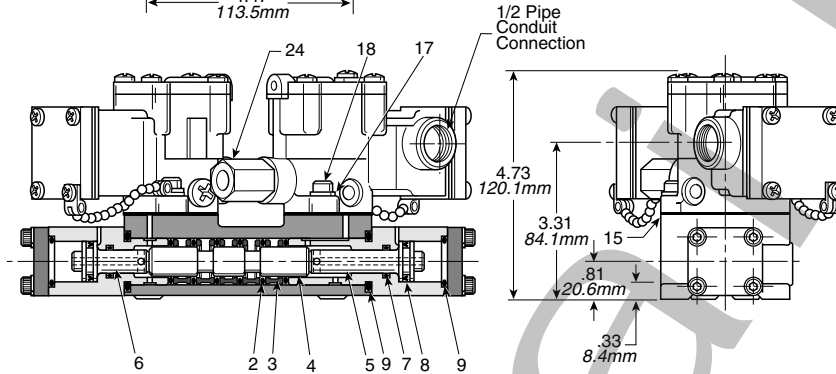

1/2" Basic

Parts List

Item No.	Part No.	Description
2	K463 001	End Spacer
* 3	—	O-Ring
4	K453 008	Spacer
5	K343 045	Spool (All Ports Blocked)
5	K343 067	Spool (Cyl. Ports Open to Inlet)
5	K343 068	Spool (Cyl. Ports Open to Exhaust)
* 6	—	Seal
* 8	—	Seal
9	K313 017	Piston
*10	—	Seal
*14	—	Gasket
16	H175 12	Lockwasher
17	H100 60	Cap Screw
24	K152 003	Override Assy.
28	K983 003	Shock Pad

* Standard Service Kit: K352 153
 * Special Service Kit: K352 353 (Continuous Duty)

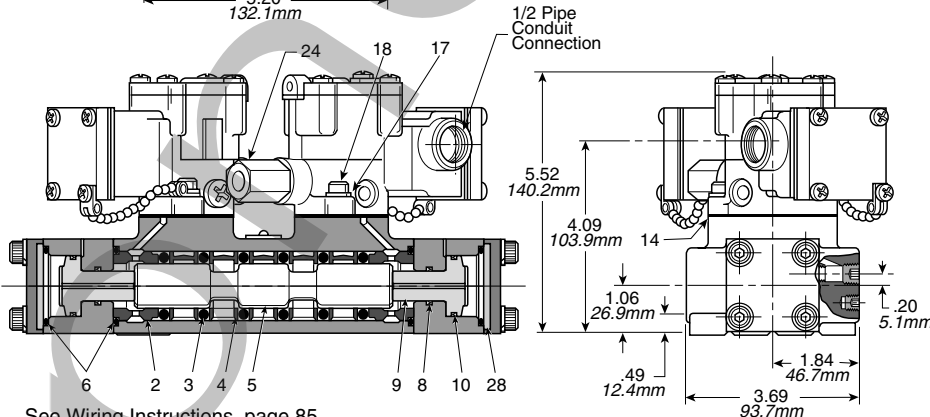

See Wiring Instructions, page 85, for units with flying leads.

4-Way, 5-Port, 3-Position - 3/8" Thru 1-1/4" NPT Ports

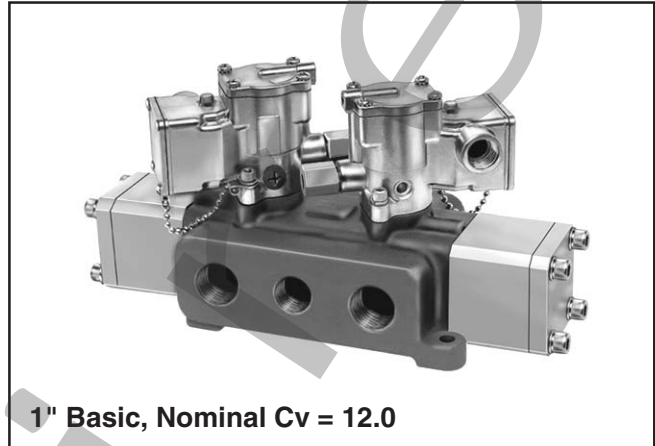
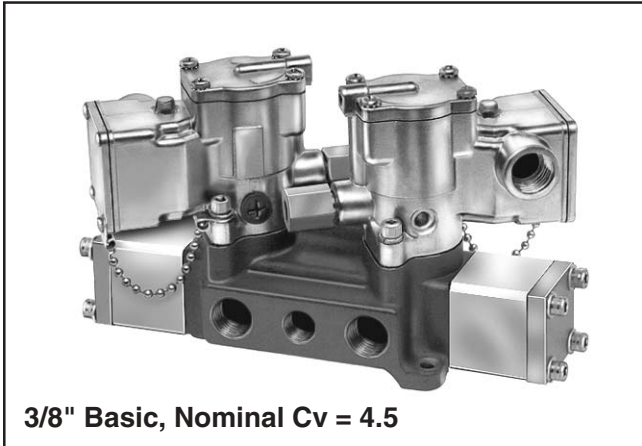

Application

These valves may be used to actuate double acting cylinders, when "inching" or incremental rod movement is desired. A "momentary" (exceeding .03 seconds) or maintained electrical signal applied to one of the solenoids shifts the valve, the valve returns to the "neutral" condition when the electrical signal is removed. Valve may be applied for alternate service. For alternate flow path usages, see *Optional Functions* page.

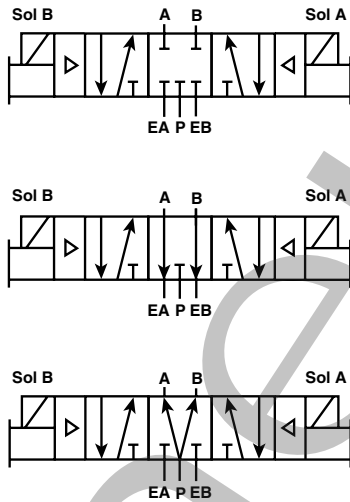

Operation: Pressure Service

Neutral "Class 21"

Both solenoids de-energized (Normal Condition) – All ports blocked.

Neutral "Class 22"

Both solenoids de-energized (Normal Condition) – "Cylinder" Port A is open to "Exhaust" Port EA, "Cylinder" Port B is open to "Exhaust" Port EB, "Pressure" Port P is blocked.

Neutral "Class 23"

Both solenoids de-energized (Normal Condition) – "Cylinder" Port A is open to Pressure Port P, "Cylinder" Port B is open to Pressure Port P. Both "Exhaust" Ports EA and EB are blocked.

Activated Operation

With solenoid "A" (solenoid nearest Port B on valve body) energized – Pressure at Port P is connected to "Cylinder" Port A, "Cylinder" Port B is connected to "Exhaust" Port EB.

With solenoid "B" (solenoid nearest Port A on valve body) energized – Pressure at Port P is connected to "Cylinder" Port B, "Cylinder" Port A is connected to "Exhaust" Port EA.

Model Selection (Neutral "Class 21" Shown)

Valve		Voltage	Port Size (NPT)		Type
3/8" Basic Size	1" Basic Size		P, A & B	EA & EB	
L695 39 211 53	—	120V 60Hz 110V 50Hz	3/8"	1/2"	Junction Box
L695 49 211 53	—		1/2"	1/2"	
—	L695 79 211 53		3/4"	1"	
—	L695 89 211 53		1"	1-1/4"	
—	L695 99 211 53		1-1/4"	1-1/4"	
L695 36 211 **	—	Other	3/8"	1/2"	Basic
L695 46 211 **	—		1/2"	1/2"	
—	L695 76 211 **		3/4"	1"	
—	L695 86 211 **		1"	1-1/4"	
—	L695 96 211 **		1-1/4"	1-1/4"	

See page 48 for variations in class of neutral configuration and (**) voltage codes.

Dimensional Data & Service Kits

L695, 3/8" & 1" Basic Valve

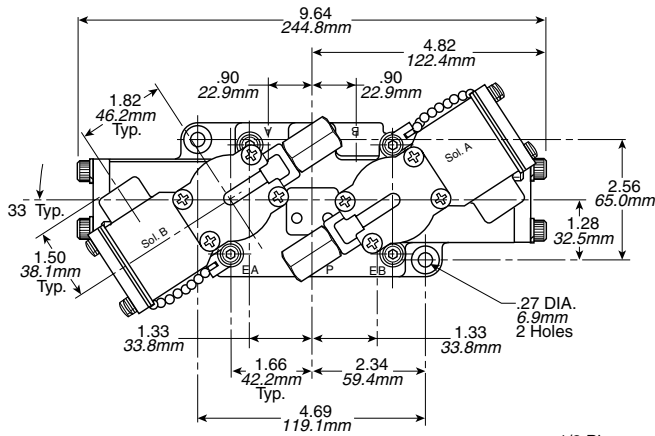

3/8" BASIC

Parts List

Item No.	Part No.	Description
* 2	—	O-Ring (Dynamic)
3	K453 028	Spacer
4	K463 012	End Spacer
5	K343 124	Spool (All Ports Blocked)
5	K343 126	Spool (Cyl. Ports Open to Inlet)
5	K343 125	Spool (Cyl. Ports Open to Exhaust)
* 6	—	Seal
* 8	—	Seal
9	K313 049	Piston
*10	—	Seal
*14	—	Gasket
16	H175 12	Lockwasher
17	H100 60	Cap Screw
24	K152 003	Override Assy.
*27	—	O-Ring (Static)
29	K983 002	Shock Pad

* Standard Service Kit: K352 126
 * Special Service Kit: K352 127 (Continuous Duty)

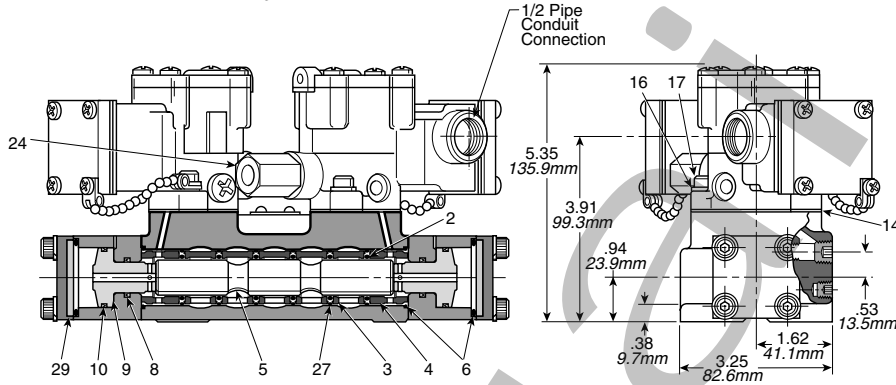

1" BASIC

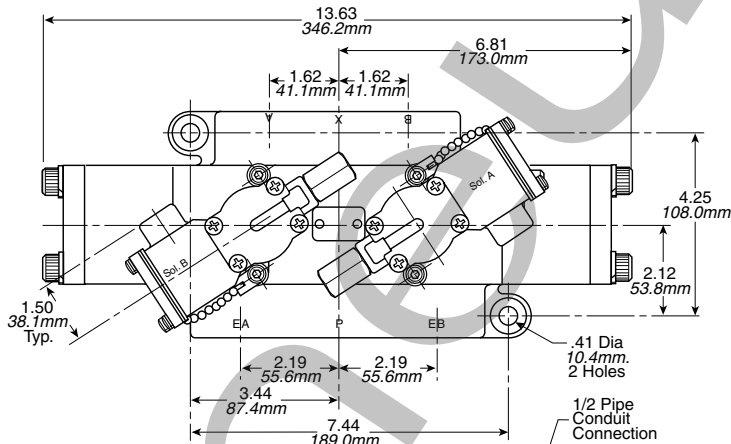

Parts List

Item No.	Part No.	Description
2	K463 005	End Spacer
* 3	—	O-Ring (Static)
* 4	—	O-Ring (Dynamic)
5	K453 009	Spacer
6	K343 060	Spool (All Ports Blocked)
6	K343 070	Spool (Cyl. Ports Open to Exhaust)
6	K343 069	Spool (Cyl. Ports Open to Inlet)
* 7	—	Seal
* 9	—	Seal
10	K313 023	Piston
*11	—	Seal
*15	—	Gasket
17	H175 12	Lockwasher
18	H100 60	Cap Screw
25	K152 003	Override Assy.
29	K983 004	Shock Pad

* Standard Service Kit: K352 130
 * Special Service Kit: K352 131 (Continuous Duty)

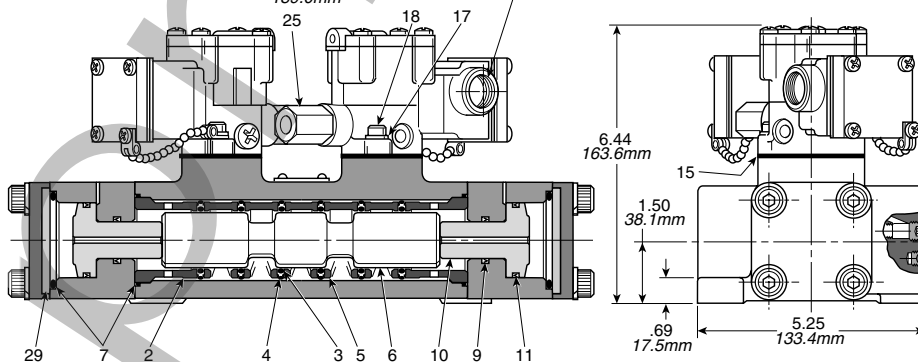

See Wiring Instructions, page 85, for units with flying leads.

Remote Air Pilot Operated

4-Way, 4-Port, 3-Position & 4-Way, 5-Port, 3-Position

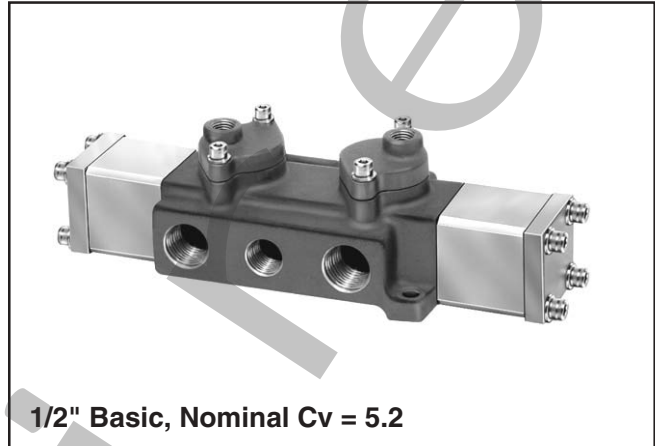

Application

These valves may be used to actuate double acting cylinders, when "inching" or incremental rod movement is desired. A normally open pilot signal to both pilot caps maintains the valve in its neutral (centered) condition. Valve may be applied for alternate service. For alternate flow path usages, see *Optional Functions* page.

Operation: Pressure Service

Neutral "Class 21"

Normally open pilot signals to both pilot caps – All ports blocked.

Neutral "Class 22"

Normally open pilot signals to both pilot caps – "Cylinder" Port A is connected to "Exhaust" Port E (EA) and "Cylinder" Port B is connected to "Exhaust" Port E (EB). Pressure at Port P is blocked.

Neutral "Class 23"

Normally open pilot signals to both pilot caps – "Cylinder" Port A & B are connected to Port P. "Exhaust" Port(s) E (EA and EB) are blocked.

Activated Operation

When Pilot A is exhausted – Pressure at Port P is connected to "Cylinder" Port A. "Exhaust" Port E (EB) is connected to "Cylinder" Port B.

When Pilot B is exhausted – Pressure at Port P is connected to "Cylinder" Port B, "Exhaust" Port E (EA) is connected to "Cylinder" Port A.

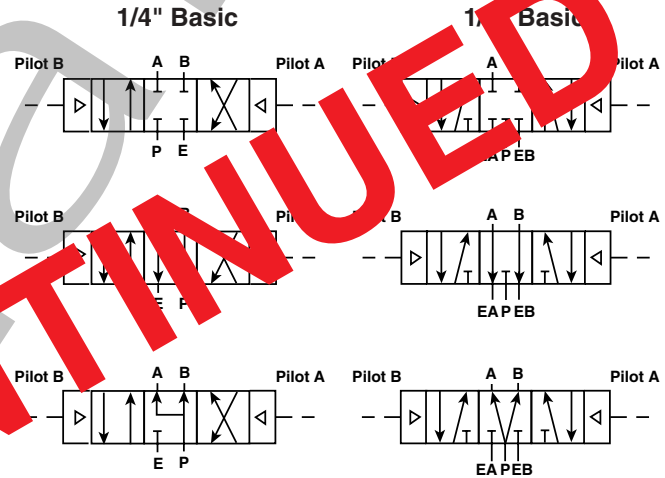

Model Selection (Neutral "Class 21" Shown)

Valve	Port Size (NPT)	
	P, A & B	Exhaust
L474 21 211	1/4"	3/8"
L474 31 211	3/8"	3/8"
L624 51 211	1/2"	3/4"
L624 61 211	3/4"	3/4"

See page 47 & 49 for variations on ordering other neutral class configurations.

Note: Shaded units are no longer available.

Dimensional Data & Service Kits

L474 & L624, 1/4" & 1/2" Basic Valve

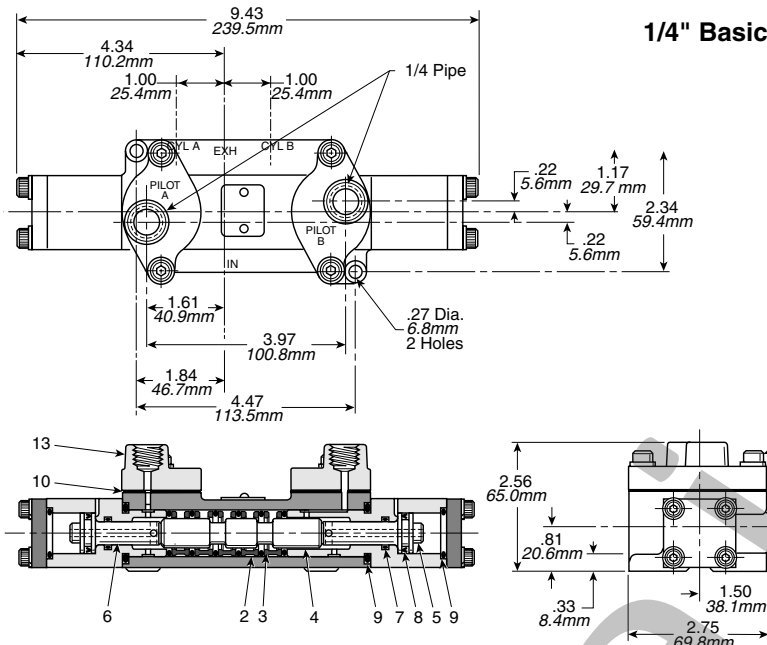

1/4" Basic

Parts List

Item No.	Part No.	Description
* 2	—	O-Ring
3	K453 005	Spacer
4	K343 020	Spool (All Ports Blocked)
4	K343 021	Spool (Cyl. Ports Open to Exhaust)
4	K343 073	Spool (Cyl. Ports Open to Inlet)
5	K313 009	Piston (Long)
6	K313 010	Piston (Short)
* 7	—	Seal
* 8	—	Seal
* 9	—	Seal
*10	—	Gasket
11	H175 12	Lockwasher
12	H100 60	Cap Screw
13	K323 027	Remote Cap

* Standard Service Kit: K352 357

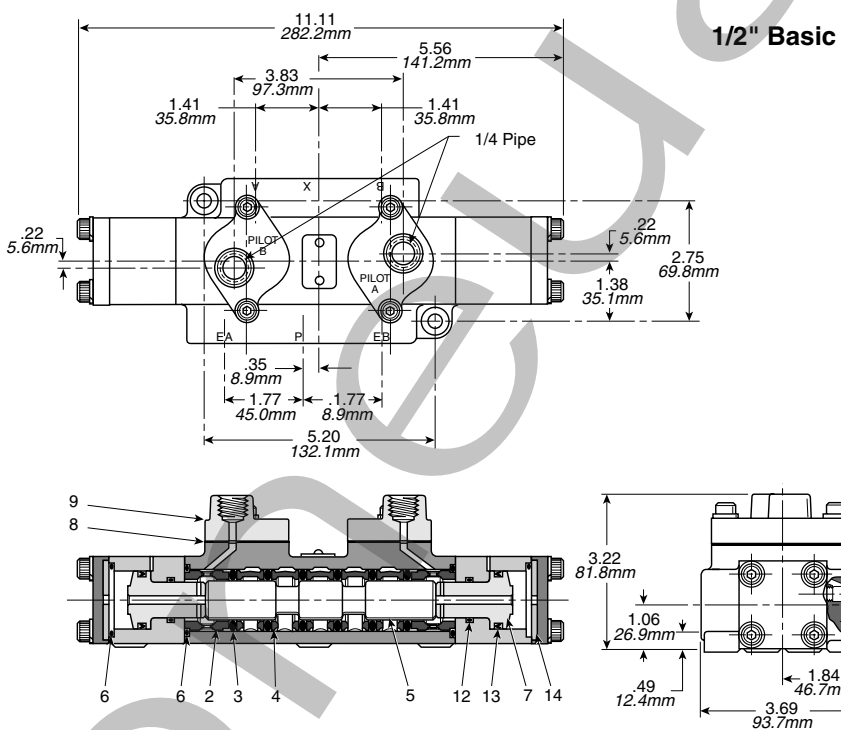

1/2" Basic

Parts List

Item No.	Part No.	Description
2	K463 001	End Spacer
* 3	—	O-Ring
4	K453 008	Spacer
5	K343 045	Spool (All Ports Blocked)
5	K343 057	Spool (Cyl. Ports Open to Inlet)
5	K343 068	Spool (Cyl. Ports Open to Exhaust)
* 6	—	Seal
7	K313 017	Piston
* 8	—	Gasket
9	K323 027	Remote Cap
10	H100 60	Cap Screw
11	H175 12	Lockwasher
*12	—	Seal
*13	—	Seal
14	K983 003	Shock Pad

* Standard Service Kit: K352 358

4-Way, 5-Port, 3-Position - 3/8" Thru 1-1/4" NPT Ports

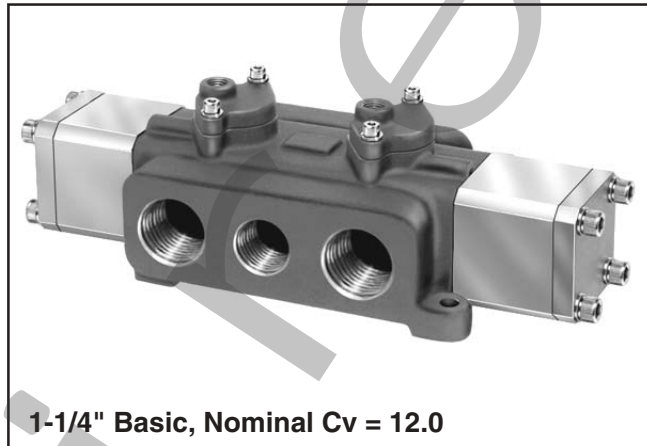
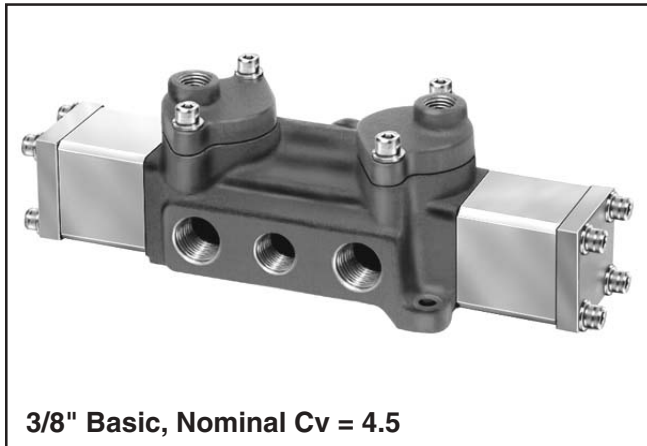

Application

These valves may be used to activate double acting cylinders when "inching" or incremental rod movement is desired. A normally open pilot signal to both pilot caps maintains the valve in its neutral (centered) condition. Valve may be applied for alternate services. For alternate flow path usages, see *Optional Functions* page.

Operation: Pressure Service

Neutral "Class 21"

Normally open pilot signals to both pilot caps – All ports blocked.

Neutral "Class 22"

Normally open pilot signals to both pilot caps – "Cylinder" Port A is connected to "Exhaust" Port EA and "Cylinder" Port B is connected to "Exhaust" Port EB. Pressure at Port P is blocked.

Neutral "Class 23"

Normally open pilot signals to both pilot caps – "Cylinder" Ports A & B are connected to Port P. "Exhaust" Ports EA & EB are blocked.

Activated Operation

When Pilot "A" (nearest Port B on valve body) is exhausted – Pressure at Port P is connected to "Cylinder" Port A. "Exhaust" Port EB is connected to "Cylinder" Port B.

When Pilot "B" (nearest Port A on valve body) is exhausted – Pressure at Port P is connected to "Cylinder" Port B. "Exhaust" Port EA is connected to "Cylinder" Port A.

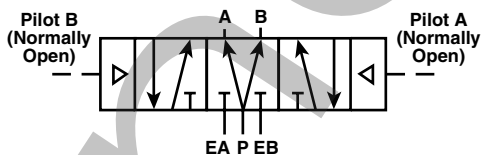
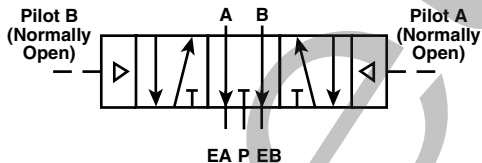
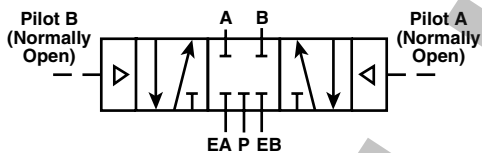

Model Selection (Neutral "Class 21" Shown)

Valve	Port Size (NPT)	
	P, A & B	EA & EB
L694 31 211	3/8"	1/2"
L694 41 211	1/2"	1/2"
L694 71 211	3/4"	1"
L694 81 211	1"	1-1/4"
L694 91 211	1-1/4"	1-1/4"

See page 48 for ordering other neutral configurations.

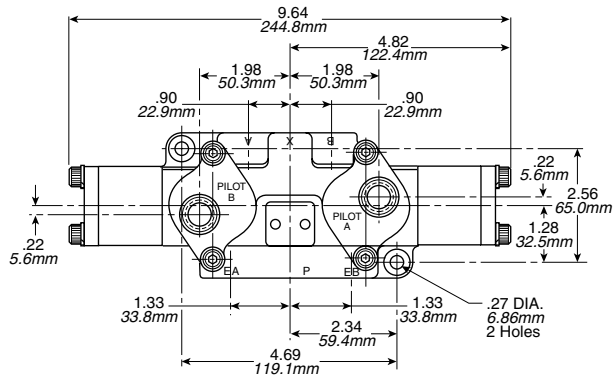

3/8" Basic

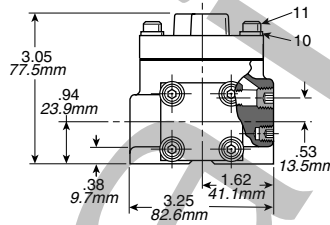
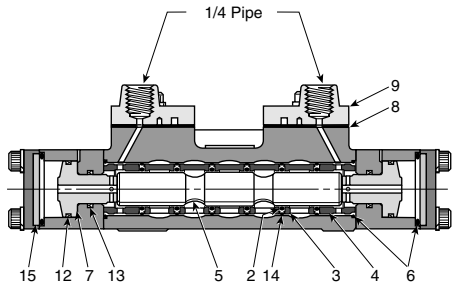

Parts List

Item No.	Part No.	Description
* 2	—	O-Ring (Dynamic)
3	K453 028	Spacer
4	K463 012	End Spacer
5	K343 124	Spool (All Ports Blocked)
5	K343 126	Spool (Cyl. Ports Open to Inlet)
5	K343 125	Spool (Cyl. Ports Open to Exhaust)
* 6	—	Seal
7	K313 049	Piston
* 8	—	Gasket
9	K323 027	Remote Cap
10	H175 12	Lockwasher
11	H100 60	Cap Screw
*12	—	Seal
*13	—	Seal
*14	—	O-Ring (Static)
15	K983 002	Shock Pad

* Standard Service Kit: K352 355

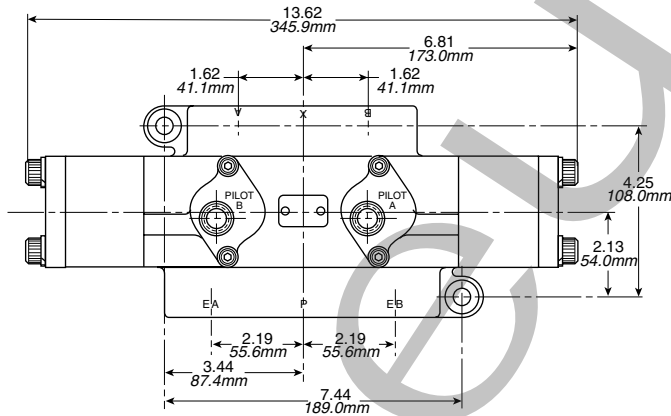

1" Basic

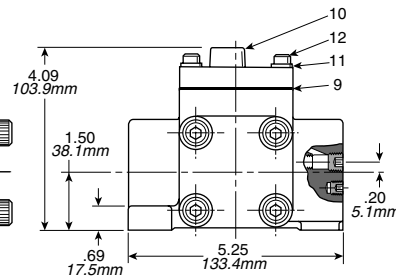
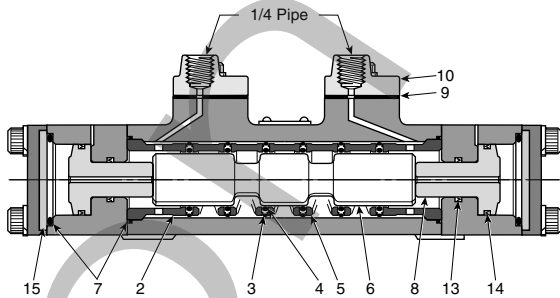

Parts List

Item No.	Part No.	Description
2	K463 005	End Spacer
* 3	—	O-Ring (Static)
* 4	—	O-Ring (Dynamic)
5	K453 009	Spacer
6	K343 060	Spool (All Ports Blocked)
6	K343 070	Spool (Cyl. Ports Open to Exhaust)
6	K343 069	Spool (Cyl. Ports Open to Inlet)
* 7	—	Seal
8	K313 023	Piston
* 9	—	Gasket
10	K323 027	Remote Cap
11	H175 12	Lockwasher
12	H100 60	Cap Screw
*13	—	Seal
*14	—	Seal
15	K983 004	Shock Pad

* Standard Service Kit: K352 360

Accessories

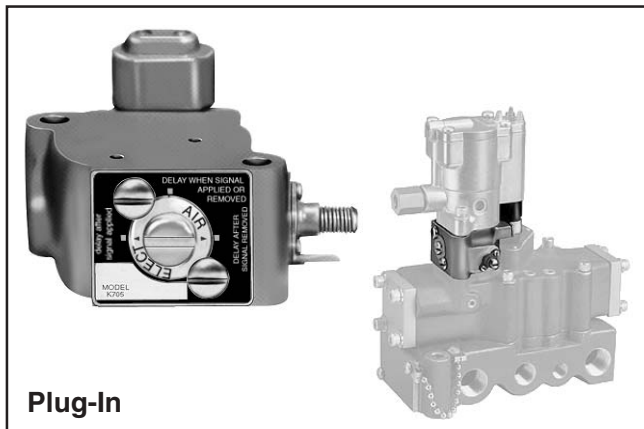

Plug-In

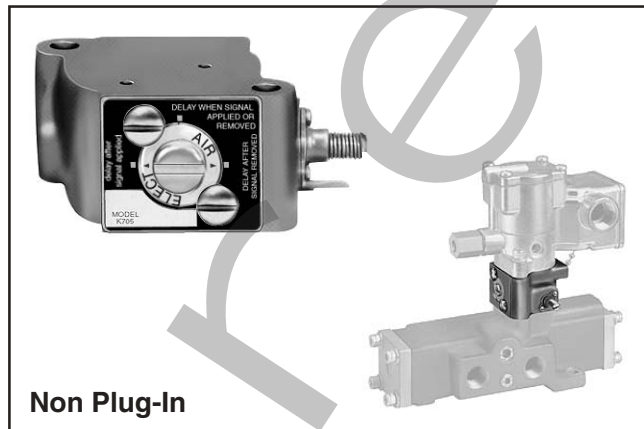

Non Plug-In

Time Delay Modules Provide

- Delay of valve action upon application of control signal, removal of control signal or both application and removal of control signal.
- Delay Intervals from 0-6, 5-12, or 10-30 seconds... up to several minutes with the addition of a small external reservoir.
- Repeatability within 10%, using clean filtered air.
- Change of function without disassembly... with line pressure on the valve.

Function

Time Delay Modules provide precise, consistent delay of valve shift. They eliminate the need for electrical timers and relays and simplify circuitry.

Delay interval is controlled by an externally adjustable metering screw. Change of function is accomplished by loosening two lock screws turning the slotted selector plate to the desired function and re-tightening the lock screws.

By adding a small external reservoir, delay interval can be extended up to several minutes.

For accuracy and good repeatability, use filtered air to the pilot and be sure all gaskets are tight.

Setting Selector for Desired Function

For Valves which are Solenoid Pilot Operated, or Valves being controlled by normally open remote pilot, match the pointer marked "Elect" with the desired function indicator line.

For Valves which are being controlled by normally closed pilot, match the pointer marked "Air" with the desired function indicator line.

How To Order

To order Time Delay Modules, select model number for delay interval required. Modules are furnished with gaskets, screws, and installation instructions.

Plug-In Kit Number	Delay Interval
K705 2001	0 - 6 Second Delay
K705 2002	5 - 12 Second Delay
K705 2003	10 - 30 Second Delay

Non Plug-In Kit Number	Delay Interval
K705 1001	0 - 6 Second Delay
K705 1002	5 - 12 Second Delay
K705 1003	10 - 30 Second Delay

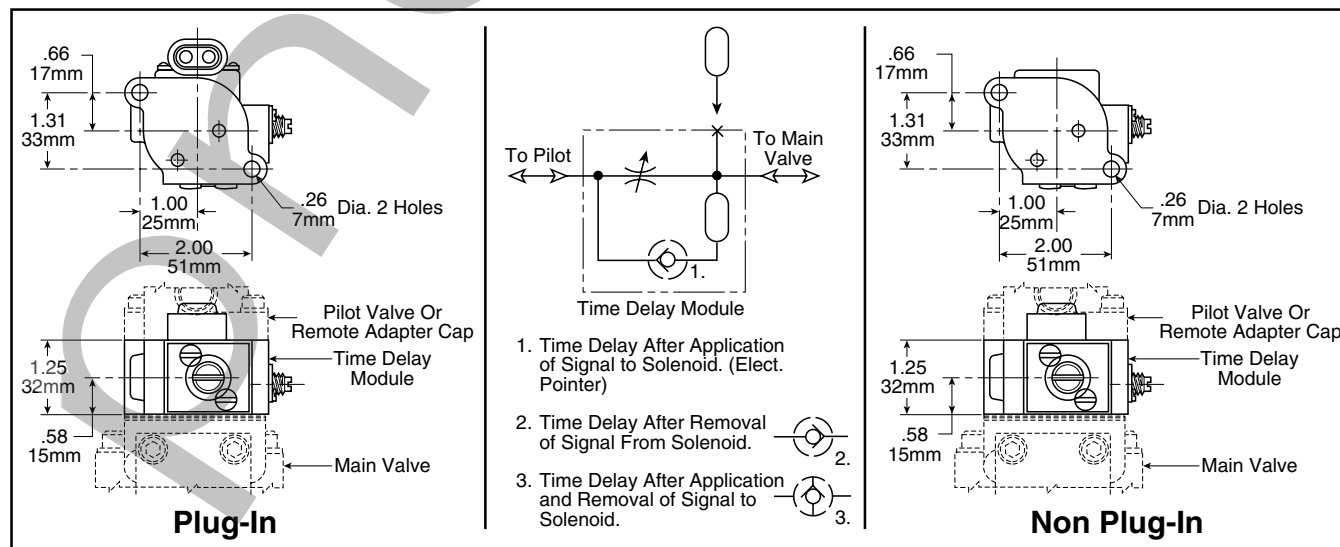

Accessories

"Blank Station" Covers	
Manifold Assembly	Blank Cover Kit
K142 076	K060 20007
K142 077	
K142 230	K060 20003
K142 231	
K142 270	
K142 233	
K142 234	K060 20009
K142 235	
K142 236	K060 20004
K142 237	

"Flush Type" Hex Drive Pipe Plugs for Port Isolation	
Part No.	Size (NPTF)
K21R02012	1/8"
K21R02025	1/4"
K21R02037	3/8"
K21R02050	1/2"
K21R02075	3/4"
K21R02100	1"
H074 72	1-1/4"
H074 30	1-1/2"

Electrical Connectors Single or Double Solenoid Valves					
Basic Size	Valve Body		Subbase/Manifold		
	Single Sol.	Double Sol.	19" Leads	72" Leads	12' Leads
1/4"	H027 17	H027 26	H027 19	—	—
3/8"					
1/2"	H027 23	H027 22	H027 13	H027 89	H027 40
1"					

Interchangeable Manual Override Assemblies for Solenoid Operators



Non-Locking Type
K162 001
Locking Type
K152 003

Notes: Shaded units are not standard stock items.

L□□□ □□ □□□ **
|| Voltage Code

Effective June 1, 1990 the Flush Locking Override replaced the Extended Knob Locking Override as the Schrader Bellows standard. The part number remains K152 003. To override valve, use a flat head screwdriver to press in and rotate plunger 90° until plunger locks in place. For proper valve operation, override should be in the out position.

Voltage Suffix Codes						
Code **	Voltage			Coil Number		Replace With
	60 Hz	50 Hz	DC	Plug-In	Flying Lead (19") *	
40	12	—	3	K593 052	K593 007	
42	24	—	6	K593 048	K593 003	
43	27	24	—	K593 061	K593 015	K593 048 / K593 003
45	—	—	12†	K593 055	K593 010	
49	—	—	24†	K593 060 K593 274 ‡	K593 014	
51	—	130	48†	K593 074	K593 028	
53	120 †	110	—	K593 071 K593 125 ‡	K593 025	
57	240 †	220	—	K593 081	K593 035	
60	—	—	90	—	K393 020	
61	—	—	120	—	K593 041	

Notes: Shaded areas are no longer available.

Bold Face type indicated primary coil rating.

† - Indicates voltages approved for solenoid operators designed for use in hazardous locations. (See page 87.)

* - 19" Coil lead length is standard. Other lead lengths may be available, consult supplier.

‡ - Assembly includes indicator light socket, less light.

Service Kits

To use this chart you must know the Basic Valve Series, Quantity, and Type of Operators, or the first three characters of the Valve Model Number.

Basic Valve		Solenoid Operated *				Remote Pilot Operated	
		Standard Service (Intermittent Duty)		Special Service ** (Continuous Duty)			
Size	Series (Prefix)	Single	Double 2 & 3-Position	Single	Double 2 & 3-Position	Single	Double 2 & 3-Position
1/4"	L41	–	K352 151	–	K352 351	–	K352 357
	L42	–	K352 151	–	K352 351	–	K352 357
	L44	K352 150	–	K352 350	–	K352 363	–
	L46	–	K352 151	–	K352 351	–	K352 357
	L47	–	K352 151	–	K352 351	–	K352 357
	L48	K352 150	–	K352 350	–	K352 363	–
3/8" *	L65	–	K352 126	–	K352 127	–	K352 355
	L66	–	K352 126	–	K352 127	–	K352 355
	L67	K352 124	–	K352 125	–	K352 362	–
	L68	–	K352 126	–	K352 127	–	K352 355
	L69	–	K352 126	–	K352 127	–	K352 355
	L70	K352 124	–	K352 125	–	K352 362	–
1/2"	L51	–	K352 153	–	K352 353	–	K352 358
	L52	–	K352 153	–	K352 353	–	K352 358
	L54	K352 152	–	K352 352	–	K352 361	–
	L61	–	K352 153	–	K352 353	–	K352 358
	L62	–	K352 153	–	K352 353	–	K352 358
	L64	K352 152	–	K352 352	–	K352 361	–
1" †	L65	–	K352 130	–	K352 131	–	K352 360
	L66	–	K352 130	–	K352 131	–	K352 360
	L67	K352 128	–	K352 129	–	K352 359	–
	L68	–	K352 130	–	K352 131	–	K352 360
	L69	–	K352 130	–	K352 131	–	K352 360
	L70	K352 128	–	K352 129	–	K352 359	–

Notes:

- * Kits for solenoid operated valves include solenoid service kits.
- ** Special service (continuous duty) solenoids may be identified as having gold colored solenoid tops.
- † Valvair II valves are easily identified by gold colored valve end caps.

Conversion Kits: Lubricated to Non-Lubricated Operation

Basic Size	Operators (Solenoid or Remote Pilot)				
	Single	Double (2-Position)	Double (3-Position)		
			All Ports Blocked	Cyl. to Exh.	Cyl. to Inlet
3/8"	K322 012	K322 013	K322 014	K322 015	K322 016
1"	K352 359 K092 070 K092 071	K352 360 (K092 070) (2-Req'd)	K352 360 (K103 103 Gold Colored) End Caps 2-Req'd		

Replacement Parts

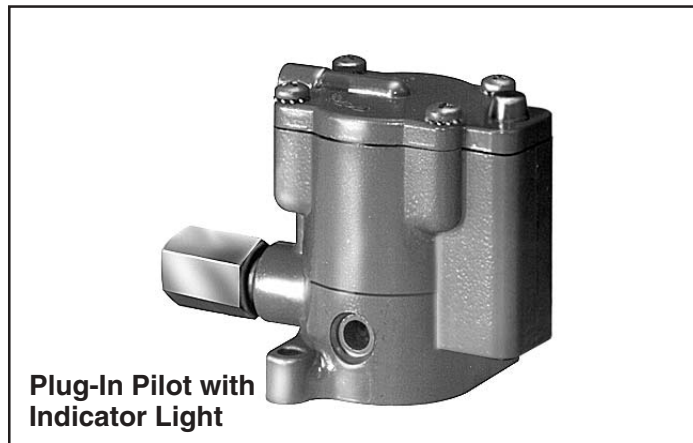

Replacement Pilots

Description	Standard Service		Special Service	
	Locking	Non-Locking	Locking	Non-Locking
With Override (120VAC)	K175 9035 53	K175 8035 53	K185 9025 53	K185 8025 53
With Override (Other than 120VAC)	K175 3035**	K175 2035**	K185 3025**	K185 2025**

** See voltages on page 75.

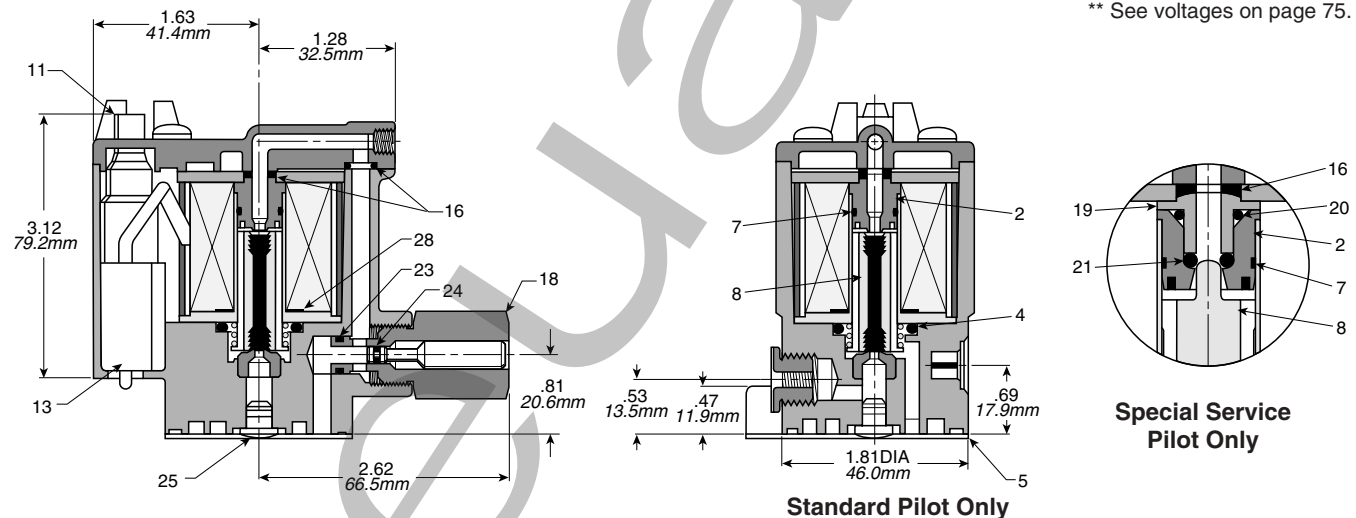

Parts List

Item No.	Part Number	Description
2	K423 005	Top Seat (STD. Service)
	K423 010	Top Seat (SPL. Service)
* 4	H142 13	Seal
* 5	K183 001	Gasket
* 7	H249 69	O-Ring
* 8	K343 002	Plunger (STD. Service)
	K343 001	Plunger (SPL. Service)
11	H191 05	Light (120 AC)
	H191 12	Light (24VDC)
13	K593 125	Coil 120V 60Hz / 110V 50 Hz, for Indicator Light**
	K593 071	Coil 120V 60Hz / 110V 50Hz
	K593 081	Coil 240V 60 Hz / 220V 50 Hz
	K593 048	Coil 6VDC / 12V 60Hz
	K593 055	Coil 12VDC
	K593 274	Coil 24VDC, for Indicator Light**
	K593 060	Coil 24VDC

Item No.	Part Number	Description
* 16	H142 01	Seal
18	K152 003	Override Assembly
19	K213005	Insert
* 20	H134 13	O-Ring
* 21	H134 73	O-Ring
* 23	H134 58	O-Ring
* 24	H134 62	O-Ring
* 25	K333 002	Plug
28	K183 108	Gasket

* Parts included in Service Kit. (For other voltages see page 75.)
 Special Service Kit K352 366
 Standard Service Kit K352 166

** Light not included with coil.

Note: Shaded units are no longer available.

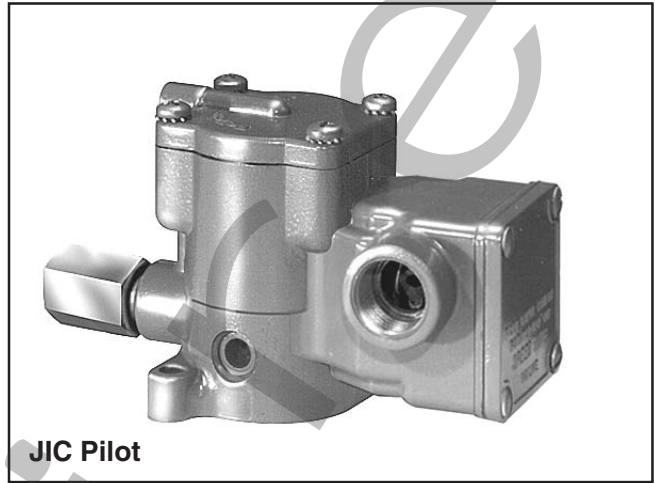
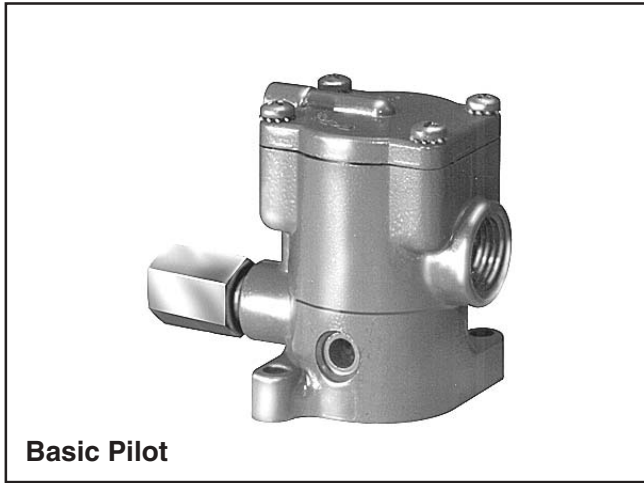

Replacement Pilots

Description	Standard Service		Special Service	
	Locking	Non-Locking	Locking	Non-Locking
Basic with Override	K065 3035**	K065 2035**	K085 3025**	K085 2025**
JIC with Junction Box & Override	K065 6035**	K065 5035**	K085 6025**	K085 5025**
JIC Pilot with Junction Box & Override & Indicator Lights (120VAC Only)	K065 9035**	K065 8035**	K085 9025**	K085 8025**

** See voltages on page 77.

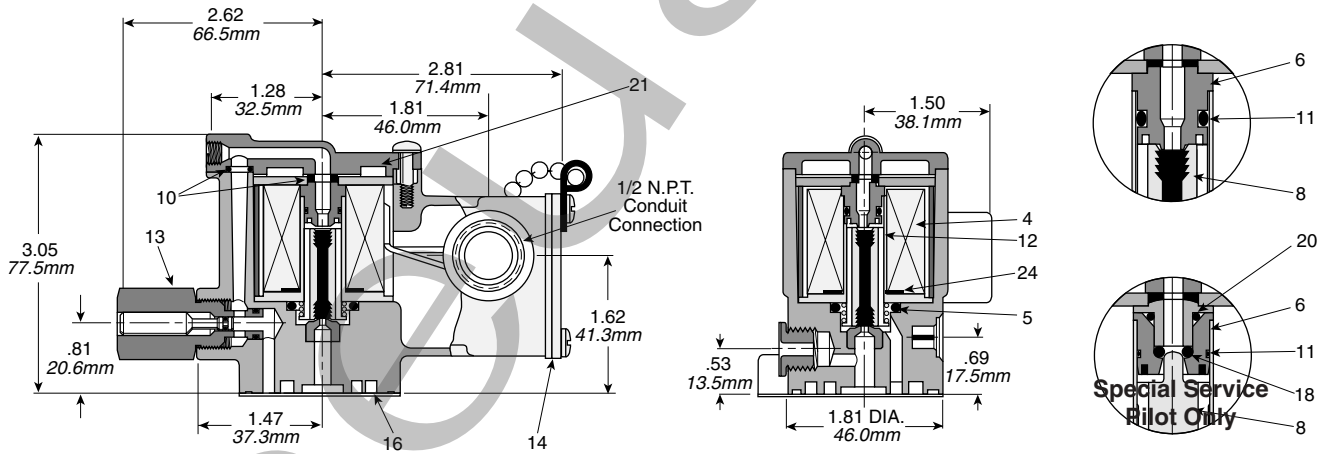

Parts List

Item No.	Part Number	Description
4	K593 025	Coil 120V 60Hz / 110V 50Hz
	K593 035	Coil 240V 60Hz / 220V 50Hz
	K593 003	Coil 6VDC / 12V 60Hz
	K593 010	Coil 12VDC
	K593 014	Coil 24VDC
	K593 041	Coil 120VDC
5	H142 13	Seal
6	K423 006	Top Seat
	K423 010	Top Seat (SPL. Service Pilot)
8	K343 002	Plunger (STD. Service)
	K343 001	Plunger (SPL. Service)
* 10	H142 01	Seal
* 11	H249 69	O-Ring

Item No.	Part Number	Description
12	K272 004	Plunger Guide
13	K152 003	Override Assembly
* 14	K183 047	Cover Gasket
* 16	K183 001	Gasket
* 18	H134 73	O-Ring
* 20	H134 13	O-Ring
* 21	H147 01	Shock Pad
22	H191 02	120 AC Only – Indicator Light
24	K183 108	Gasket

Coil leads are 19" long (For other voltages see page 75).

* Parts included in Service Kit.
 Special Service Kit K352 366
 Standard Service Kit K352 166

NOTE: Shaded units are no longer available.

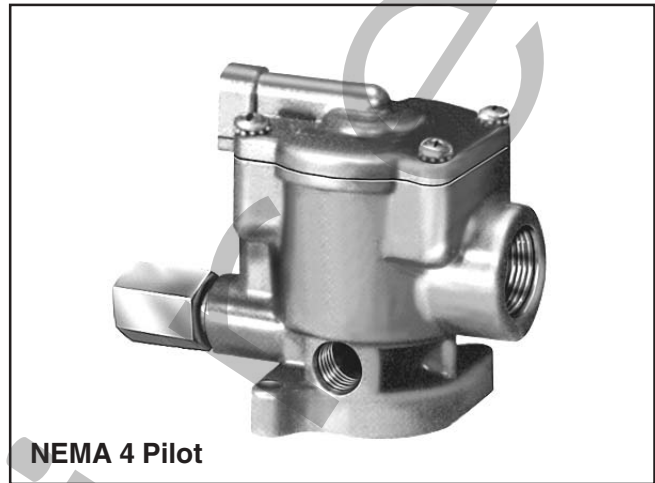
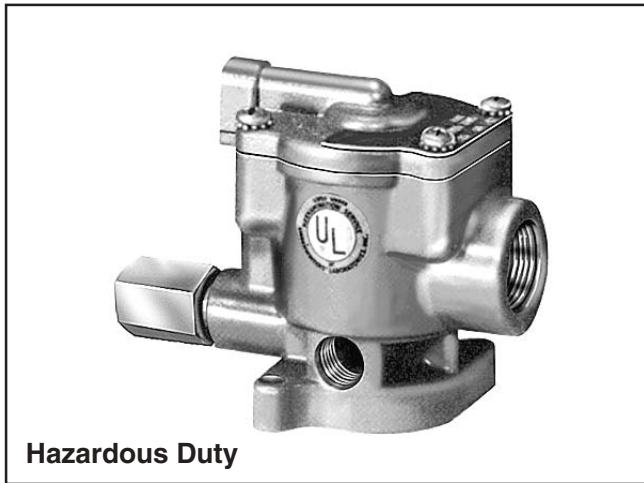

Replacement Pilots

Description	Standard Service		Special Service	
Hazardous Duty Pilot - UL & CSA	K025 1035▲ **		K045 1025▲ **	
NEMA 4 Pilot	K235 1035▲ **		K255 1025▲ **	
Override Type	Locking	Non-Locking	Locking	Non-Locking
Hazardous Duty with Override	K025 3035▲ **	K025 2035▲ **	K045 3025▲ **	K045 2025▲ **
NEMA 4 with Override	K235 3035▲ **	K235 2035▲ **	K255 3025▲ **	K255 2025▲ **

▲ 49 / 53 only

** See voltages on page 77.

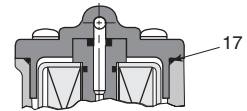
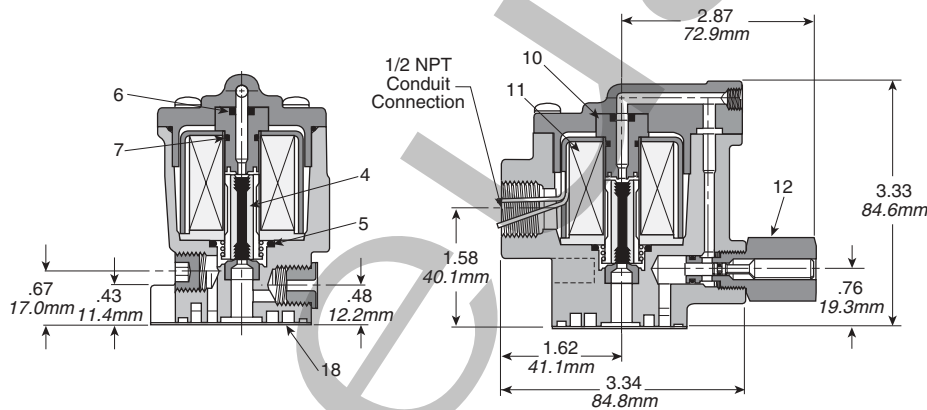

NEMA 4 Rated Pilot Only

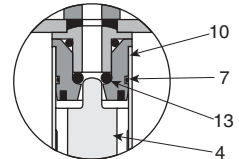

Special Service Pilot Only

Parts List

Item No.	Part Number	Description
* 4	K343 002	Plunger (STD. Service)
	K343 001	Plunger (SPL. Service)
* 5	K142 13	Seal
* 6	H134 11	O-Ring
	H134 61	O-Ring (STD. Service)
* 7	H249 69	O-Ring (SPL. Service)
10	K423 001	Top Seat
	K423 002	Top Seat (SPL. Service)
11	K593 025	Coil 120V 60Hz / 110V 50Hz
	K593 035	Coil 240V 60Hz / 220V 50Hz
	K593 003	Coil 6VDC / 12V 60Hz
	K593 010	Coil 12VDC
	K593 014	Coil 24VDC
	K593 041	Coil 120VDC

Item No.	Part Number	Description
12	K152 003	Override Assembly
* 13	H134 73	O-Ring
* 17	H137 16	Gasket (NEMA 4 Rated Pilot Only)
* 18	K183 001	Gasket

Coil leads are 19" long (For other voltages see page 75).

* Parts included in Service Kit.

Special Service Kit K352 366

Standard Service Kit K352 166

NOTE: Shaded units are no longer available.

Technical Information

Optional Functions

Speed King, Valves are exceptionally versatile and may be used to perform a wide variety of functions, some of which are illustrated here for your convenience.

**Standard 4-Way
Directional Control**

4-Ported Valves

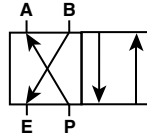

5-Ported Valves

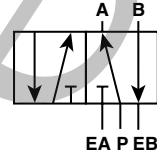

**4-Way With Exhaust Port
Speed Control**

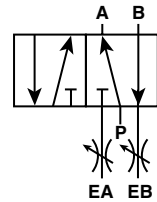
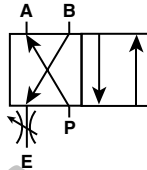

3-Way Normally Closed

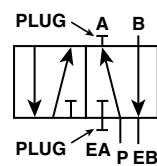
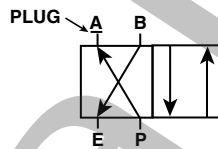

3-Way Normally Open

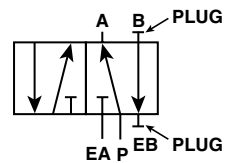
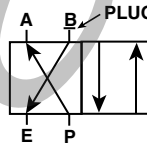

**Pressure Selector
P1 Must Be 35-140 PSI
P2 May Be 0-250 PSI or Vacuum**

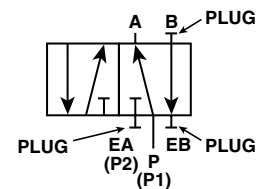
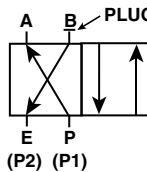

2-Way Normally Closed

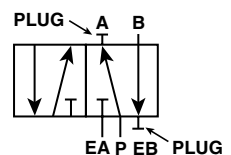
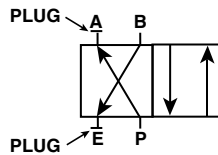

2-Way Normally Open

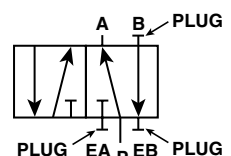
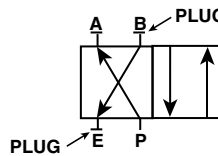

**Dual Pressure 4-Way
X- External Pilot Supply 35-140 PSI
P1 & P2 May Be 0-250 PSI or Vacuum**

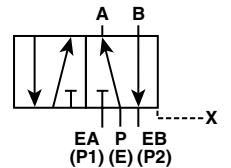

Technical Information

Flow Capacities

The capacity curves shown in the chart are for theoretical valve having a $C_v = 1.0$ for air at standard conditions –temperature 68°F, 36% relative humidity and 14.7 PSI absolute pressure.

To estimate the SCFM capacity of a valve, if the supply or initial pressure is known, proceed as follows:

Assuming initial pressure to 100 PSIG, select the 100 PSI initial pressure curve and follow it upward and to the left edge of the chart. Read the flow in SCFM (in this example flow is approximately 56 SCFM). Multiply the SCFM flow obtained in the chart by the C_v for valve and flow path desired shown in the accompanying table.

To estimate valve size for a known required flow and initial pressure, divide the required SCFM flow by the SCFM obtained from the flow chart. Select the required valve size from the valves listed in the table which have a C_v that slightly exceeds the quotient.

For example: Assuming 200 SCFM required flow, 100 PSIG initial pressure, divide 200 SCFM by 56 SCFM (max. flow from chart). The quotient is 3.57 (200/56 = 3.57). Valves with a C_v of 3.57 or greater selected from the table will provide the required flow.

To estimate flow capacity at a specific “final pressure,” locate the desired final pressure on the bottom scale of the chart. Follow a vertical line upward until it intersects the initial pressure curve. Then follow a horizontal line from that point to the left edge of the chart. Read SCFM flow. Multiply SCFM obtained in chart by C_v of selected valve for flow.

C_v Method

Data at Std. Conditions
 68°F Temperature
 14.7 PSI Abs. Pressure
 36% Relative Humidity

$G =$ Specific Gravity of fluid related to air = 1 @
 14.7 psia, 68°F, 36% Relative Humidity

$P_2 =$ Downstream Pressure (psia)
 $\Delta P_c =$ Component pressure drop

$Q =$ Flow Rate (scfm) at 14.7 psia, 68°F,
 36% Relative Humidity

$T_1 =$ Upstream Temperature °R (°R = °F + 460)

$$Q = 22.48 C_v \sqrt{\frac{(\Delta P_c) \times (P_2)}{(T_1) \times (G)}}$$

$C_v =$ Flow Coefficient

Flow Rating determined in accordance with
 NFPA recommended Standard NFPA/T3.21.3-1972.

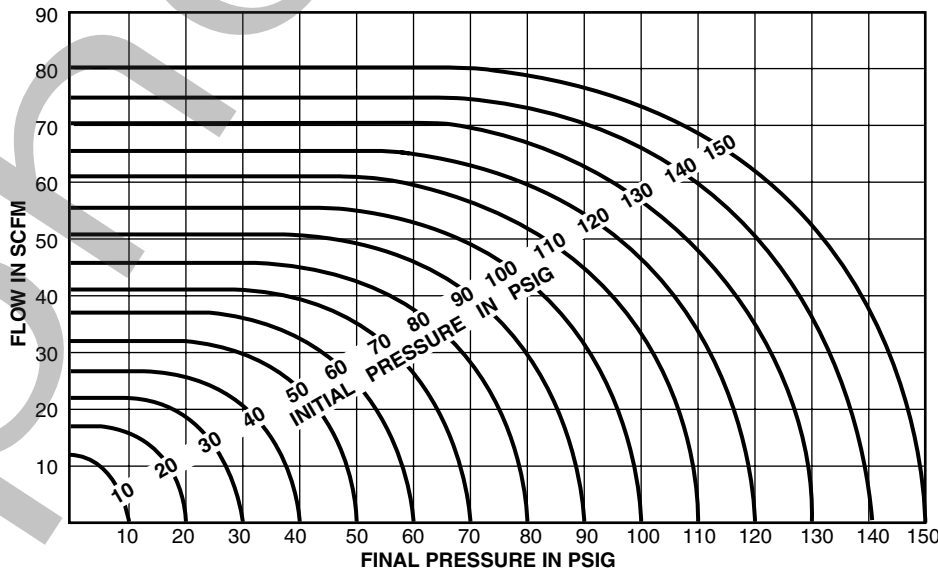

Technical Information

Flow Capacities

Valve Type	Cylinder Port Size (NPTF)	Mounting Style	Cv Flow Rating			
			Inlet to Cylinder "A"	Inlet to Cylinder "B"	Cylinder "A" To Exhaust	Cylinder "B" To Exhaust
1/4" Single	1/4"	Subbase	1.2	1.4	1.1	1.1
	1/4"	Manifold	1.1	1.3	1.0	1.0
3/8" Single	3/8"	Subbase	4.8	4.8	4.5	4.8
	1/2"	Subbase	5.5	5.1	5.3	4.9
	3/4"	Subbase	5.1	4.9	5.3	5.1
	3/8"	Manifold	4.5	4.2	4.0	4.0
	1/2"	Manifold	5.0	4.5	4.7	4.5
	3/4"	Manifold	4.8	4.4	4.9	4.5
1/2" Single	1/2"	Subbase	5.1	4.5	5.2	4.8
	3/4"	Subbase	5.3	5.0	5.4	5.2
	1/2"	Manifold	4.6	4.5	4.6	4.5
	3/4"	Manifold	4.8	4.9	4.9	4.8
1" Single	3/4"	Subbase	10.1	11.0	10.4	9.9
	1"	Subbase	12.3	11.8	11.8	11.8
	1-1/4"	Subbase	12.4	11.6	12.4	12.7
	3/4"	Manifold	10.7	10.7	10.9	10.9
	1"	Manifold	11.6	12.1	12.1	11.6
	1-1/4"	Manifold	12.6	12.6	12.6	11.9
1/4" Double	1/4"	Subbase	1.4	1.7	1.3	1.4
	1/4"	Manifold	1.3	1.6	1.3	1.4
3/8" Double	3/8"	Subbase	4.5	4.4	4.5	4.0
	1/2"	Subbase	5.5	5.0	5.1	5.0
	3/4"	Subbase	5.0	5.0	5.5	5.5
	3/8"	Manifold	4.5	4.0	4.0	4.0
	1/2"	Manifold	4.8	4.4	4.7	4.8
	3/4"	Manifold	4.9	4.4	5.1	4.6
1/2" Double	1/2"	Subbase	4.8	5.1	5.1	5.0
	3/4"	Subbase	5.5	5.1	5.9	5.5
	1/2"	Manifold	4.4	4.5	4.5	4.7
	3/4"	Manifold	5.0	4.8	5.2	5.1
1" Double	3/4"	Subbase	10.9	11.1	10.3	10.3
	1"	Subbase	11.4	11.9	11.9	11.4
	1-1/4"	Subbase	12.0	12.0	11.8	12.0
	3/4"	Manifold	10.7	10.2	10.9	10.9
	1"	Manifold	12.3	11.5	11.2	11.2
	1-1/4"	Manifold	12.8	11.9	11.9	11.6
1/4" Double 3-Position	1/4"	Subbase	1.4	1.7	1.5	1.4
	1/4"	Manifold	1.3	1.7	1.5	1.4
3/8" Double 3-Position	3/8"	Subbase	3.8	3.9	4.0	3.9
	1/2"	Subbase	4.2	4.7	5.2	5.0
	3/4"	Subbase	4.5	4.5	4.4	4.6
	3/8"	Manifold	3.7	3.8	4.2	4.1
	1/2"	Manifold	3.9	4.0	4.9	4.6
	3/4"	Manifold	4.1	3.9	4.2	4.0

Technical Information

Flow Capacities

Valve Type	Cylinder Port Size (NPTF)	Mounting Style	C _v Flow Rating			
			Inlet to Cylinder "A"	Inlet to Cylinder "B"	Cylinder "A" To Exhaust	Cylinder "B" To Exhaust
1/2" Double 3-Position	1/2"	Subbase	4.7	4.8	4.8	4.8
	3/4"	Subbase	5.5	4.8	5.3	5.0
	1/2"	Manifold	4.2	4.2	4.4	4.8
	3/4"	Manifold	4.8	4.6	4.6	5.0
1" Double 3-Position	3/4"	Subbase	10.2	10.3	9.9	10.3
	1"	Subbase	10.6	11.0	11.4	10.9
	1-1/4"	Subbase	11.6	11.6	11.8	11.6
	3/4"	Manifold	9.8	10.0	10.6	10.1
	1"	Manifold	10.8	11.1	11.1	10.8
	1-1/4"	Manifold	11.3	11.8	11.9	11.4
1/2" Single Sol. Poppet	1/2"	Subbase	4.1	4.2	5.0	4.8
	3/4"	Subbase	4.3	4.4	5.2	5.2
	1/2"	Manifold	4.2	4.8	4.4	4.6
	3/4"	Manifold	4.6	4.6	4.5	4.8
1/4" Single	1/4"	Direct Pipe	1.8	2.2	1.8	1.9
	3/8"	Direct Pipe	2.0	2.2	1.9	2.0
3/8" Single	3/8"	Direct Pipe	4.7	4.6	4.7	4.9
	1/2"	Direct Pipe	5.3	5.2	5.3	5.5
1/2" Single	1/2"	Direct Pipe	5.1	5.1	5.2	5.3
	3/4"	Direct Pipe	5.6	5.2	5.6	5.9
1" Single	3/4"	Direct Pipe	10.9	10.9	11.9	11.9
	1"	Direct Pipe	12.4	13.0	13.0	13.3
	1-1/4"	Direct Pipe	12.9	12.5	13.1	13.1
1/4" Double	1/4"	Direct Pipe	1.8	1.7	1.9	1.7
	3/8"	Direct Pipe	1.8	1.9	1.9	2.0
3/8" Double	3/8"	Direct Pipe	4.5	4.7	4.7	4.8
	1/2"	Direct Pipe	5.5	5.2	5.1	5.3
1/2" Double	1/2"	Direct Pipe	5.2	5.0	5.1	5.5
	3/4"	Direct Pipe	5.7	5.5	5.7	5.8
1" Double	3/4"	Direct Pipe	10.9	11.4	10.9	11.4
	1"	Direct Pipe	12.5	12.5	11.9	12.5
	1-1/4"	Direct Pipe	13.0	13.6	13.0	13.0
1/4" Double 3-Position	1/4"	Direct Pipe	1.7	1.6	1.9	1.8
	3/8"	Direct Pipe	1.8	1.9	1.9	1.9
3/8" Double 3-Position	3/8"	Direct Pipe	4.1	4.1	4.2	4.1
	1/2"	Direct Pipe	4.5	4.2	4.5	4.8
1/2" Double 3-Position	1/2"	Direct Pipe	5.0	4.7	5.2	5.5
	3/4"	Direct Pipe	5.4	5.0	5.3	5.7
1" Double 3-Position	3/4"	Direct Pipe	10.6	11.1	10.9	10.4
	1"	Direct Pipe	11.0	11.4	12.1	11.8
	1-1/4"	Direct Pipe	12.1	12.5	12.5	12.0

Materials of Construction

Valve Bodies: Aluminum alloy

Valve Spool: * Aluminum alloy with special coating on 3/8" & 1" basic valves

Hard chrome plated AISI type 416 stainless steel on 1/4" & 1/2" basic valves.

Resilient Seals: In Valve Body -

Dynamic: Polyurethane base on 3/8" & 1" basic valves*

Static/Dynamic: Nitrile base w/12% Molybdenum Disulphide on 1/4" & 1/2" basic valves

Other Seals: Nitrile

Shock Pads: Polyurethane

Valve Spacers: Brass

Manifolds & Subbases: Aluminum alloy

Solenoid Bodies: Plated zinc alloy

Internal Components: Corrosion resistant steel

Resilient Seals: Standard service - Nitrile
Special service (continuous duty)-
Fluorocarbon & Silicone

Other Seals: Nitrile

Coil: Class "B" epoxy encapsulated
(Class "H" also available on some models,
consult supplier)

* These materials are specially designed for valves used on non-lubricated service.

Valve Selection

Safety factors are designed into each valve. However, it is important that the application requirements do not exceed the limits stated for pressure and temperature.

"Nominal C_v " ratings are given on each ordering page. These represent an average of performance for all flow-paths of a given valve size. Valves should be sized to an application using actual C_v (Flow Coefficient) values. See *Flow Capacities* Section for this data.

Life Expectancy

Valves designed for non-lubricated service as well as those designed for lubricated service will provide millions of maintenance free cycles. Under laboratory conditions service life exceeds 25,000,000 cycles!

Factory Pre-Lubrication

Valves are lubricated at assembly with Sunaplex 781 or equivalent. Valves specified for vacuum service are lubricated with Dow Corning Valve Seal A.

Valves for Non-Lubricated Service

3/8" and 1" basic valve sizes are designed to operate in applications where in-service lubrication is not desirable. Valves are factory pre-lubed as noted above. These valves may be used for lubricated service as well.

Lubrication

Air Line Lubricant (compatible with Nitrile & Polyurethane seals) must readily atomize and be of the medium aniline type. Aniline point range must be between 180° and 220°F. Viscosity @ 100°F: 140-170 SUS.

Recommended Lubricant

If in-service lubrication is required, use F442 oil, or equivalent. F442 is specially formulated to provide peak performance and maximum service life for air operated equipment.

Installation

Valves should be installed with reasonable accessibility for service. Exercise care in keeping piping lengths to a minimum. Piping should be free of dirt, chips & scale. Pipe joint compound should be used sparingly applied only to the thread, never to the valve body. Avoid undue strain at piping joints. Protect the valve from exposure to extreme temperatures, dirt and moisture to maximize life.

Note: Valves equipped with locking manual overrides. Override(s) must be in the fully extended position for proper valve operation.

Double Solenoid/Remote Caution

Note: It is recommended that double solenoid and double remote 2-Position valves be mounted with the main spool in the horizontal plane.

Wiring Instructions for Base Mounted Valves

Single Solenoid:

Use wires marked "2" & "3" for connection. Units with DC Solenoids and indicator lights are polarity sensitive. Wire marked "3" is positive (+).

Double Solenoid:

Use wires marked "1" & "2" for Solenoid "A". Use wires marked "3" & "4" for Solenoid "B". Units with DC Solenoids and indicator lights are polarity sensitive. Wires marked "1" and "3" are positive.

⚠ Caution: DC Solenoids are polarity sensitive. Observe polarities indicated above.

Units with flying leads

Wires are not polarity sensitive.

⚠ Caution: DC solenoids with indicator lights and/or arc suppression coils are polarity sensitive. Use red wire as positive.

Listing Agencies

General Purpose Approvals

CSA - Canadian Standards Association
File Number 42024

Hazardous Duty Approvals

UL - Underwriters Laboratories, Inc.
File Number E42542
Category Y107

CSA - Canadian Standards Association
File Number 24349

See page 87 for Approved Hazardous Location Class, Group & Division.

"Special Service" Solenoid (Continuous Duty)

Special Service Solenoids are designed for use when the solenoid duty cycle is greater than 70% or when energization times are for 10 minutes or longer.

These solenoids should be used when valves are to be held energized for hours, days or weeks... or when extended ambient temperature operation is required. Apply the duty cycle formula to determine if this type of solenoid is required.

Duty Cycle Formula

$$\frac{\text{Time Energized}}{\text{Time Energized} + \text{Time Off}} \times 100 = \% \text{ Duty Cycle}$$

If Duty Cycle is 70% or greater, then Special Service (Continuous Duty) Solenoid should be used.

Pilot Supply Conversion

Base Mounted

For field conversion to external pilot supply, remove two 1/8" NPTF plugs from top of valve body and move bottom plug from "Y" to "Z". Replace 1/8" NPTF plugs and connect pilot pressure to the 1/4" NPTF external pilot supply port "X" in subbase.

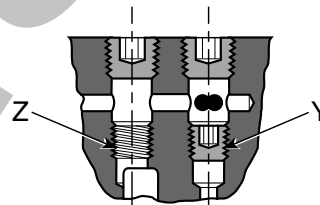

Direct Pipe Ported

For field conversion to external pilot supply, remove and discard 1/4" NPTF plug in external pilot supply port "X". Move stored plug "Y" to location "Z" in bottom of pilot supply port "X". Then connect pilot pressure to port "X" in valve body.

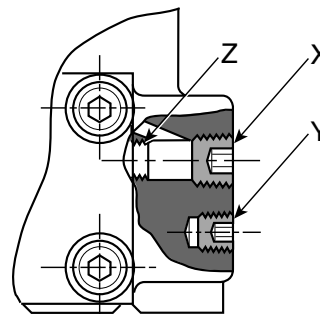

Technical Information

Pressure Range for Solenoid Operated Valves

Media	Internal Pilot Supply Basic Valve Size				External Pilot Supply Basic Valve Size				
	1/4"	3/8"	1/2"	1"	1/4"		3/8"	1/2"	1"
Air	35-140* PSIG				N.A.	Main	0-250 PSIG		
						Pilot	35-140* PSIG		
Vacuum	Do Not Use				N.A.	Main	Within 1 Hg of Perfect		
						Pilot	35-140* PSIG		
Other	Consult Supplier								

* **Note:** 200 PSIG Solenoid Is Optional (consult supplier).

Pressure Range for Remote Pilot Operated Valves

Media		Valve Type	
		Single	Double & 3-Position
Air	Main	35-250 PSIG	0-250 PSIG
	Pilot	35-200 PSIG	35-200 PSIG
Vacuum	Main	Do Not Use	Within 1" Hg of Perfect
	Pilot	Do Not Use	35-200 PSIG
Other	Consult Supplier		

Ambient Temperature Range Standard Service Solenoid Operator

Minimum	Maximum	
	Intermittent Duty	Continuous Duty
0°F	125°F	100°F

Ambient Temperature Range Remote Pilot Operated Valves

Remote Pilot	
Minimum	Maximum
0°F	200°F

Special Service (Continuous Duty) Solenoid Operator

Minimum	Maximum	
	Intermittent Duty	Continuous Duty
0°F	125°F	125°F

As the above chart indicates, Standard Duty Solenoids may be used on continuous duty but ambient temperature is de-rated.

In some cases, Special Service Solenoids may be rated for higher ambient temperatures (consult supplier).

Caution

If it is possible that the ambient temperature may fall below freezing, the medium must be moisture free to prevent internal damage and unpredictable behavior.

Technical Information

Solenoid Enclosure Ratings

Type	Listing Agency	NEMA Rating	Description
Plug-In	CSA	1 & 12	General Purpose Indoor Only Dust Tight
Conduit / Flying Lead	CSA	1 & 12	General Purpose Indoor Only Dust Tight
* Conduit (As Specified)	UL & CSA	7 & 9	Hazardous Location (See Chart Below)
* Conduit (As Specified)	CSA	4	General Purpose Indoor / Outdoor Watertight

* See ordering information on specific valve type. (Direct Pipe Ported Valves Only.)

Hazardous Duty Solenoid Listing

Valves with solenoid operators designated for hazardous locations are UL & CSA Approved as follows:

National Electric Code	Ambient Conditions	NEMA Classification
Class I Div. 1 Group C	Ethyl, Ether, Etc., Gases & Vapors	VII (7)
Class I Div. 1 Group D	Gasoline, Etc., Gases & Vapors	VII (7)
Class I Div. 2 Group B	Butadiene, Etc., Liquid, Fluid or Vapor Normally Contained, or Atmosphere Ventilated	VII (7)
Class II Div. 1 Group E	Metal Dust	IX (9)
Class II Div. 1 Group F	Coal, Coke, Carbon Black Dust	IX (9)
Class II Div. 1 Group G	Flour, Starch, Grain Dust	IX (9)

See Article 500 - Hazardous (Classified) Locations, National Electric Code.

Voltage Code Replacement Coils & Electrical Characteristics

Voltage Code: **Final Two Digits** in valve model number

L □ □ □ □ □ □ □ □ □ □ **
Voltage Code

Voltage Code **	Voltage	Plug-In Style Coil Number	Flying Leads Coil Number	Electrical Characteristics				
				Watts	Inrush Amps	Holding Amps	V/A	
							Inrush	Hold
45	12VDC	K593 055	K593 010	8	—	.66	—	7.92
49	24VDC	K593 060	K593 014	8	—	.32	—	7.68
53	120V/60Hz	K593 125	K593 025	9	.29	.18	31.2	—
	110V/50Hz			7	.32	.22	23.1	—
57	240V/60Hz	K593 081	K593 035	13	.18	.12	41.4	—
	220V/50Hz			9	.13	.09	29.9	—

Other voltages are available, see page 75.

Standard Product Crossover Information

SK-200 – 1/4"

SK-200 1/4"	Suggested Replacement	SK-200 1/4"	Suggested Replacement	SK-200 1/4"	Suggested Replacement
L46421102	L46431102	L4652910453	L4653910453	L4852310257	L4853310257
L4652W10242	Refer to Service Kits	L47421211	Refer to Service Kits	L4852310259	Refer to Service Kits
L4652W60453	L4653Z60453	L47421221	Refer to Service Kits	L4852310260	Refer to Service Kits
L4652W80453	L4653Z80453	L47421231	Refer to Service Kits	L4852310261	Refer to Service Kits
L4652Y10261	Refer to Service Kits	L4752291153	Refer to Service Kits	L4852310262	Refer to Service Kits
L4652Z10253	L4653Z10253	L4752321143	Refer to Service Kits	L4852310445	Refer to Service Kits
L4652210249	L4653310249	L4752321153	L4753321153	L4852310449	L4853310449
L4652210253	L4653310253	L4752321157	L4753321157	L4852310453	L4853310453
L4652210257	L4653310257	L4752322149	Refer to Service Kits	L4852310457	Refer to Service Kits
L4652260253	L4653360253	L4752322153	Refer to Service Kits	L4852310459	Refer to Service Kits
L4652260453	L4653360453	L4752323153	Refer to Service Kits	L4852360249	L4853360249
L4652280253	L4653380253	L4752371145	Refer to Service Kits	L4852360253	L4853360253
L4652310240	Refer to Service Kits	L4752371153	Refer to Service Kits	L4852360257	L4853360257
L4652310242	Refer to Service Kits	L4752372153	Refer to Service Kits	L4852360449	L4853360449
L4652310245	Refer to Service Kits	L4752391153	Refer to Service Kits	L4852360453	L4853360453
L4652310249	L4653310249	L4752621145	Refer to Service Kits	L4852360457	Refer to Service Kits
L4652310253	L4653310253	L4752621153	L4752621153	L4852380249	L4853380249
L4652310253L	L4653310253	L4752621161	Refer to Service Kits	L4852380253	L4853380253
L4652310257	L4653310257	L4752622153	Refer to Service Kits	L4852380261	Refer to Service Kits
L4652310261	Refer to Service Kits	L4752622157	Refer to Service Kits	L4852380453	L4853380453
L4652310453	L4653310453	L4752623151	Refer to Service Kits	L4852410245	Refer to Service Kits
L4652360249	L4653360249	L4752623153	Refer to Service Kits	L4852410253	L4853610253
L4652360253	L4653360253	L4752921153	L4753921153	L4852510245	Refer to Service Kits
L4652360257	Refer to Service Kits	L4752922153	Refer to Service Kits	L4852510249	L4853610249
L4652380249	L4653380249	L4752923153	Refer to Service Kits	L4852510253	L4853610253
L4652380253	L4653380253	L48421102	L48431102	L4852510257	L4853610257
L4652380257	Refer to Service Kits	L4852W10253	L4853Z10253	L4852510449	L4853610449
L4652380261	Refer to Service Kits	L4852W10453	L4853Z10453	L4852610242	Refer to Service Kits
L4652380357	Refer to Service Kits	L4852W60253	L4853Z60253	L4852610243	Refer to Service Kits
L4652380453	L4653380453	L4852W60453	L4853Z60453	L4852610245	Refer to Service Kits
L4652510249	L4653610249	L4852W80253	L4853Z80253	L4852610249	L4853610249
L4652510253	L4653610253	L4852W80453	L4853Z80453	L4852610251	Refer to Service Kits
L4652510257	L4653610257	L4852Y10253	L4853Z10253	L4852610253	L4853610253
L4652610240	Refer to Service Kits	L4852Y10453	L4853Z10453	L4852610257	L4853610257
L4652610242	Refer to Service Kits	L4852Z10253	L4853Z10253	L4852610259	Refer to Service Kits
L4652610245	Refer to Service Kits	L4852Z10453	L4853Z10453	L4852610261	Refer to Service Kits
L4652610249	L4653610249	L4852110249	L4853310249	L4852610449	L4853610449
L4652610253	L4653610253	L4852110253	L4853310253	L4852610453	L4853610453
L4652610257	L4653610257	L4852110257	L4853310257	L4852610457	Refer to Service Kits
L4652610259	Refer to Service Kits	L4852110453	L4853310453	L4852610459	Refer to Service Kits
L4652610261	Refer to Service Kits	L4852160253	L4853360253	L4852610460	Refer to Service Kits
L4652610353	L4653610353	L4852210249L	L4853310249	L4852610461	Refer to Service Kits
L4652610451	Refer to Service Kits	L4852210253	L4853310253	L4852810253	L4853810253
L4652610457	Refer to Service Kits	L4852260253	L4853360253	L4852810453	L4853810453
L4652610461	Refer to Service Kits	L4852260453	L4853360453	L4852910249	L4853910249
L4652810249	L4653810249	L4852310240	Refer to Service Kits	L4852910253	L4853910253
L4652810253	L4653810253	L4852310242	Refer to Service Kits	L4852910253L	L4853910253
L4652910249	L4653910249	L4852310243	Refer to Service Kits	L4852910349	L4853910349
L4652910253	L4653910253	L4852310245	Refer to Service Kits	L4852910353	L4853910353
L4652910253L	L4653910253	L4852310249	L4853310249	L4852910453	L4853910453
L4652910353	L4653910353	L4852310253	L4853310253	L41421102	Refer to Service Kits
L4652910449	L4653910449	L4852310253L	L4853310253	L4152110245	Refer to Service Kits

Standard Product Crossover Information

SK-200 – 1/4"

SK-200 1/4"	Suggested Replacement	SK-200 1/4"	Suggested Replacement	SK-200 1/4"	Suggested Replacement
L4152110253	L4152310253	L4452210257	L4452310257		
L4152210245	Refer to Service Kits	L4452210259	Refer to Service Kits		
L4152210253	L4152310253	L4452210353	L4452310353		
L4152210257	L4152310257	L4452210453	L4453210453		
L4152210259	Refer to Service Kits	L4452210457	Refer to Service Kits		
L4152210457	Refer to Service Kits	L4452210459	Refer to Service Kits		
L4152210459	Refer to Service Kits	L4452310242	Refer to Service Kits		
L4152310240	Refer to Service Kits	L4452310245	Refer to Service Kits		
L4152310242	Refer to Service Kits	L4452310251	Refer to Service Kits		
L4152310243	Refer to Service Kits	L4452310259	Refer to Service Kits		
L4152310245	Refer to Service Kits	L4452310345	Refer to Service Kits		
L4152310259	Refer to Service Kits	L4452310451	Refer to Service Kits		
L4152310451	Refer to Service Kits	L4452710253	L4452810253		
L4152310457	Refer to Service Kits	L4452710453	L4452810453		
L4152710453	L4152810453				
L42421211	Refer to Service Kits				
L42421221	Refer to Service Kits				
L42421231	Refer to Service Kits				
L4252W22549	Refer to Service Kits				
L4252Z22153	Refer to Service Kits				
L4252122549	Refer to Service Kits				
L4252221149	L4252321149				
L4252222145	Refer to Service Kits				
L4252222153	Refer to Service Kits				
L4252222153	Refer to Service Kits				
L4252223549	Refer to Service Kits				
L4252321143	Refer to Service Kits				
L4252322149	Refer to Service Kits				
L4252322157	Refer to Service Kits				
L4252322549	Refer to Service Kits				
L4252722153	Refer to Service Kits				
L4252822149	Refer to Service Kits				
L4252822153	Refer to Service Kits				
L4252823153	Refer to Service Kits				
L4252922149	Refer to Service Kits				
L4252922153	Refer to Service Kits				
L4252922553	Refer to Service Kits				
L4252923153	Refer to Service Kits				
L4252923553	Refer to Service Kits				
L44421102	Refer to Service Kits				
L4452W10249	L4452Z10249				
L4452W10253	L4452Z10253				
L4452W10449	L4452Z10449				
L4452110249	L4452310249				
L4452110253	L4452310253				
L4452110257	L4452310257				
L4452110449	L4452310449				
L4452110453	L4452310453				
L4452210242	Refer to Service Kits				
L4452210245	Refer to Service Kits				
L4452210249	L4452310249				
L4452210253	L4452310253				

Standard Product Crossover Information

SK-200 – 3/8"

SK-200 3/8"	Suggested Replacement	SK-200 3/8"	Suggested Replacement	SK-200 3/8"	Suggested Replacement
L6553W10253	L6553Z10253	L6753310242	Refer to Service Kits	L6854310240	Refer to Service Kits
L6553110242	Refer to Service Kits	L6753310249S	L6753310249	L6854310242	Refer to Service Kits
L6553210240	Refer to Service Kits	L6753310251	Refer to Service Kits	L6854310253L	L6854310253
L6553210242	Refer to Service Kits	L6753310259	Refer to Service Kits	L6854310261	Refer to Service Kits
L6553210249	L6553310249	L6753310351	Refer to Service Kits	L6854360249L	L6854360249
L6553210253	L6553310253	L6753710249	L6753810249	L6854380242	Refer to Service Kits
L6553210257	L6553310257	L6753710253	L6753810253	L6854380461	Refer to Service Kits
L6553210259	Refer to Service Kits	L6753810279	L6753810249	L6854410253	L6854610253
L6553210449	L6553310449	L6753910253S	L6753910253	L6854410461	Refer to Service Kits
L6553210453	L6553310453	L685D310251	Refer to Service Kits	L6854510249	L6854610249
L6553210459	Refer to Service Kits	L685D310253	L6854310253	L6854510253	L6854610253
L6553310240	Refer to Service Kits	L685D610253	L6854610253	L6854610240	Refer to Service Kits
L6553310242	Refer to Service Kits	L685D610257L	L6854640257	L6854610242	Refer to Service Kits
L6553310249S	L6553310249	L685D610259	Refer to Service Kits	L6854610259	Refer to Service Kits
L6553310251	Refer to Service Kits	L685M910253	L6854910253	L6854610261	Refer to Service Kits
L6553310259	Refer to Service Kits	L6853110253	L6853310253	L6953121153	L6953321153
L6553710253	L6553810253	L6853110253L	L6853310253	L6953121553	L6953321553
L6553810279	L6553810249	L6853110453	L6853310453	L6953122149	L6953322149
L6553910253S	L6553910253	L6853160253	L6853360253	L6953122153	L6953322153
L6553910279	L6553910249	L6853160257	Refer to Service Kits	L6953122553	L6953322553
L6653W21153	L6653Z21153	L6853180453	L6853380453	L6953271553	L6953371553
L6653W21553	L6653Z21553	L6853210253	L6853310253	L6953272153	L6953372153
L6653221142	Refer to Service Kits	L6853260253	L6853360253	L6953292153	L6953392153
L6653221145	L6653321145	L6853280253	L6853380253	L6953321159	Refer to Service Kits
L6653221149	L6653321149	L6853310240	Refer to Service Kits	L6953322161	Refer to Service Kits
L6653221153	L6653321153	L6853310253L	L6853310253	L6953371553L	L6953371553
L6653221157	L6653321157	L6853310261	Refer to Service Kits	L6953422153	L6953622153
L6653222153	L6653322153	L6853360251	Refer to Service Kits	L6953521153	L6953621153
L6653223149	L6653323149	L6853380261	Refer to Service Kits	L6953621159	Refer to Service Kits
L6653223153	L6653323153	L6853410349	L6853610349	L6953621161	Refer to Service Kits
L6653223553	L6653323553	L6853610251	Refer to Service Kits	L6953622140	Refer to Service Kits
L6653321159	Refer to Service Kits	L6853610261	Refer to Service Kits	L6953721153	L6953821153
L6653721153	L6653821153	L6853610461	Refer to Service Kits	L6954W21553	L6954Z21553
L6653721553	L6653821553	L6853910253L	L6853910253	L6954121153	L6954321153
L6653821179	L6653821149	L6854W10242	Refer to Service Kits	L6954121345	L6954321345
L6653923153S	L6653923153	L6854W10253	L6854Z10253	L6954172153	L6954372153
L6753W10253	L6753Z10253	L6854W10453	L6854Z10453	L6954221145	L6954321145
L6753W10453	L6753Z10453	L6854W60253	L685WZ60253	L6954221153	L6954321153
L6753110245	L6753310245	L6854110253	L6854310253	L6954292153	L6954392153
L6753110249	L6753310249	L6854110257	L6854310257	L6954321142	Refer to Service Kits
L6753110253	L6753310253	L6854110262	Refer to Service Kits	L6954321145	L6954321145
L6753110257	L6753310257	L6854210253	L6854310253	L6954321149L	L6954321149
L6753110449	L6753310449	L6854210257	L6854310257	L6954391149	Refer to Service Kits
L6753210240	Refer to Service Kits	L6854260253	L6854360253	L6954392149	Refer to Service Kits
L6753210242	Refer to Service Kits	L6854280253	L6854380253	L6954521553	L6954621553
L6753210245	L6753310245	L6854280453	L6854380453	L6954621142	Refer to Service Kits
L6753210249	L6753310249	L6854110262	Refer to Service Kits	L6954621143	Refer to Service Kits
L6753210253	L6753310253	L6854210253	L6854310253	L6954621161	Refer to Service Kits
L6753210257	L6753310257	L6854210257	L6854310257	L705C310253	L7053310253
L6753210259	Refer to Service Kits	L6854260253	L6854360253	L705C310259	Refer to Service Kits
L6753310240	Refer to Service Kits	L6854280253	L6854380253	L705C360253	L7053660253
L6753310241	Refer to Service Kits	L6854280453	L6854380453	L705C610253	L7053610253

Standard Product Crossover Information

SK-200 – 3/8"

SK-200 3/8"	Suggested Replacement	SK-200 3/8"	Suggested Replacement	SK-200 3/8"	Suggested Replacement
L705C910253	L7053910253	L7054W60253	L7054Z60253		
L705D610259	Refer to Service Kits	L7054W60257	Refer to Service Kits		
L705D610453	L7054610453	L7054Y10242	Refer to Service Kits		
L705M610253	L7053610253	L7054Y10253	L7054Z10253		
L705N610253	L7054610253	L7054110245	L7054Z10245		
L705N910453	L7054910453	L7054110249	L7054310249		
L7053W10253	L7053Z10253	L7054110253	L7054310253		
L7053W10345	L7053Z10345	L7054110257	L7054310257		
L7053W10445	L7053Z10445	L7054180245	Refer to Service Kits		
L7053W10449	L7053Z10449	L7054210253	L7054310253		
L7053W10457	L7053Z10457	L7054260453	L7054360453		
L7053110253	L7053310253	L7054280253	L7054380253		
L7053110445	L7053310445	L7054310240	Refer to Service Kits		
L7053110453	L7053310453	L7054310242	Refer to Service Kits		
L7053160253	L7053360253	L7054310251	Refer to Service Kits		
L7053160449	L7053360449	L7054310253L	L7054310253		
L7053160453	L7053360453	L7054310261	Refer to Service Kits		
L7053180453	L7053380453	L7054360240	Refer to Service Kits		
L7053210249	L7053310249	L7054360257	Refer to Service Kits		
L7053210253	L7053310253	L7054360453L	L7054360453		
L7053260253	L705360253	L7054380249	Refer to Service Kits		
L7053260257	Refer to Service Kits	L7054380251	Refer to Service Kits		
L7053260453	L7053360453	L7054380257	Refer to Service Kits		
L7053280253	L7053380253	L7054380453L	L7054380453		
L7053280453	L7053380453	L7054410249	L7054610249		
L7053310242	Refer to Service Kits	L7054410253	L7054610253		
L7053310259	Refer to Service Kits	L7054410257	L7054610257		
L7053310260	Refer to Service Kits	L7054410453	L7054610453		
L7053310261	Refer to Service Kits	L7054510242	Refer to Service Kits		
L7053310440	Refer to Service Kits	L7054510253	L7054610253		
L7053310461	Refer to Service Kits	L7054510257	L7054610257		
L7053360251	Refer to Service Kits	L7054510453	L7054610453		
L7053360253L	L7053360253	L7054610240	Refer to Service Kits		
L7053360453L	L7053360453	L7054610242	Refer to Service Kits		
L7053380245	Refer to Service Kits	L7054610251	Refer to Service Kits		
L7053380249	Refer to Service Kits	L7054610253L	L7054610253		
L7053380253L	L7053380253	L7054610259	Refer to Service Kits		
L7053380445	Refer to Service Kits	L7054610261	Refer to Service Kits		
L7053380449	Refer to Service Kits	L7054610353L	L7054610353		
L7053380461	Refer to Service Kits	L7054610451	Refer to Service Kits		
L6954391161	Refer to Service Kits	L7054610461	Refer to Service Kits		
L6954391561	Refer to Service Kits	L7054710253	L7054810253		
L7053510257	L7053610257	L7054710453	L7054810453		
L7053510261	Refer to Service Kits	L7053410253	L7053610253		
L7053510453	L7053610453	L7053410349	L7053610349		
L7053610242	Refer to Service Kits				
L7053610259	Refer to Service Kits				
L7053610261	Refer to Service Kits				
L7053610461	Refer to Service Kits				
L7053710253	L7053810253				
L7053910253L	L7053910253				
L7054W10453	L7054Z10453				

Standard Product Crossover Information

SK-200 – 1/2"

SK-200 1/2"	Suggested Replacement	SK-200 1/2"	Suggested Replacement	SK-200 1/2"	Suggested Replacement
L614N1102	Refer to Service Kits	L6255521153	L6256621153	L6455510257	L6456610257
L61451102	Refer to Service Kits	L6255621145	Refer to Service Kits	L6455510449	Refer to Service Kits
L615N610253	L6156610253	L6255621149	L6256621149	L6455610243	Refer to Service Kits
L615N610257	L6156610257	L6255621151	Refer to Service Kits	L6455610249	L6456610249
L615N810253	L6156810253	L6255621153	L6256621153	L6455610253	L6456610253
L6155110453L	L6156310453	L6255621157	L6256621157	L6455610257	L6456610257
L6155210449	L6156310449	L6255621161	Refer to Service Kits	L6455610261	Refer to Service Kits
L6155310242	Refer to Service Kits	L6255821553	Refer to Service Kits	L6455610262	Refer to Service Kits
L6155310249	L6156310249	L6255822153	Refer to Service Kits	L6455610449	Refer to Service Kits
L6155310253	L6156310253	L6255921149	L6256921149	L6455610453	Refer to Service Kits
L6155310257	L6156310257	L6255921153	L6256921153	L6455610457	Refer to Service Kits
L6155310261	Refer to Service Kits	L6255921553	Refer to Service Kits	L6455610461	Refer to Service Kits
L6155310349	Refer to Service Kits	L6255922149	Refer to Service Kits	L6455710253	L6456810253
L6155310462	Refer to Service Kits	L6255922153	Refer to Service Kits	L6455810253	L6456810253
L6155360253	Refer to Service Kits	L6255922553	Refer to Service Kits	L6455810453	Refer to Service Kits
L6155360257	Refer to Service Kits	L6255923153	Refer to Service Kits	L6455910253	L6456910253
L6155380253	Refer to Service Kits	L64451102	Refer to Service Kits	L6455910253L	L6456910253
L6155380449	Refer to Service Kits	L64461102	Refer to Service Kits	L6455910449	L6456910249
L6155380453	Refer to Service Kits	L645D360253	Refer to Service Kits	L6455910453	Refer to Service Kits
L6155410253	L6156610253	L645N310249	L6456310249	L645P310457	Refer to Service Kits
L6155610249	L6156610249	L645N310253	L6456310253	L51451102	Refer to Service Kits
L6155610253	L6156610253	L645N310257	L6456310257	L5155110249	L5155310249
L6155610257	L6156610257	L645N610249	L6456610249	L5155210249	L5155310249
L6155610261	Refer to Service Kits	L645N610257	L6456610257	L5155210253	L5155310253
L6155610453	L6156610453	L645N910253	L6456910253	L5155210453	Refer to Service Kits
L6155610461	Refer to Service Kits	L645N910453	Refer to Service Kits	L5155310242	Refer to Service Kits
L6155810453	L6156810453	L6455W10253	L6456Z10253	L5155310245	Refer to Service Kits
L6155910253	L6156910253	L6455W80253	Refer to Service Kits	L5155310259	Refer to Service Kits
L6155910453	L6156910453	L6455Y10249	L6456Z10253	L5155310353	Refer to Service Kits
L62451211	Refer to Service Kits	L6455Y10253	L6456Z10253	L5155310442	Refer to Service Kits
L62451221	Refer to Service Kits	L6455Y10257	L6456Z10257	L5155310449	Refer to Service Kits
L625N621151	Refer to Service Kits	L6455Z10253	L6456Z10253	L5155310451	Refer to Service Kits
L6255W21153	L6256Z21153	L6455110253	L6456310253	L5155310453	Refer to Service Kits
L6255Z22153	Refer to Service Kits	L6455210253	L6456310253	L5155810449	Refer to Service Kits
L6255121153	L6256321153	L6455280249	Refer to Service Kits	L5155810453	Refer to Service Kits
L6255221153	L6256321153	L6455310243	Refer to Service Kits	L5155910349	Refer to Service Kits
L6255271553	Refer to Service Kits	L6455310245	Refer to Service Kits	L5155910353	Refer to Service Kits
L6255272153	Refer to Service Kits	L6455310249	L6456310249	L5155910453	Refer to Service Kits
L6255273153	Refer to Service Kits	L6455310253	L6456310253	L52451211	Refer to Service Kits
L6255321143	Refer to Service Kits	L6455310253L	L6456310253	L52451221	Refer to Service Kits
L6255321145	Refer to Service Kits	L6455310257	L6456310257	L5255Z21553	Refer to Service Kits
L6255321149	L6256321149	L6455310261	Refer to Service Kits	L5255Z22153	Refer to Service Kits
L6255321153	L6256321153	L6455310353	Refer to Service Kits	L5255Z22153	Refer to Service Kits
L6255321345	Refer to Service Kits	L6455310445	Refer to Service Kits	L5255Z22553	Refer to Service Kits
L6255322142	Refer to Service Kits	L6455310453	Refer to Service Kits	L5255Z23553	Refer to Service Kits
L6255322153	Refer to Service Kits	L6455360249	Refer to Service Kits	L5255122153	Refer to Service Kits
L6255322553	Refer to Service Kits	L6455360253	Refer to Service Kits	L5255221149	L5255321149
L6255323153	Refer to Service Kits	L6455360453	Refer to Service Kits	L5255221153	L5255321153
L6255371153	Refer to Service Kits	L6455380253	Refer to Service Kits	L5255221557	Refer to Service Kits
L6255371553	Refer to Service Kits	L6455380453	Refer to Service Kits	L5255222149	Refer to Service Kits
L6255391153	Refer to Service Kits	L6455410257	L6456610257	L5255222153	Refer to Service Kits
L6255521142	Refer to Service Kits	L6455410461	Refer to Service Kits	L5255223153	Refer to Service Kits

Standard Product Crossover Information

SK-200 – 1/2"

SK-200 1/2"	Suggested Replacement	SK-200 1/2"	Suggested Replacement	SK-200 1/2"	Suggested Replacement
L5255321140	Refer to Service Kits	L5455810453	Refer to Service Kits	L645P310457	Refer to Service Kits
L5255321142	Refer to Service Kits	L5455910353	Refer to Service Kits	L645P610253	L6456610253
L5255321145	Refer to Service Kits	L5455910449	Refer to Service Kits	L645P610257	L6456610257
L5255321551	Refer to Service Kits	L5455910453	Refer to Service Kits	L645P610453	Refer to Service Kits
L5255321553	Refer to Service Kits	L6156W10242	Refer to Service Kits	L645P910253	L6456910253
L5255321557	Refer to Service Kits	L6156W10253	L615WZ10253	L6456W10251	Refer to Service Kits
L5255322143	Refer to Service Kits	L6156310240	Refer to Service Kits	L6456W10253	L6456Z10253
L5255322149	Refer to Service Kits	L6156310242	Refer to Service Kits	L6456W10453	Refer to Service Kits
L5255322153	Refer to Service Kits	L6156310249L	L615WZ10249	L6456W60253	Refer to Service Kits
L5255322157	Refer to Service Kits	L6156310261	Refer to Service Kits	L6456W60257	Refer to Service Kits
L5255322549	Refer to Service Kits	L6156310453	Refer to Service Kits	L6456W80249	Refer to Service Kits
L5255323143	Refer to Service Kits	L6156360253	Refer to Service Kits	L6456W80253	Refer to Service Kits
L5255323149	Refer to Service Kits	L6156380253	Refer to Service Kits	L6456W80257	Refer to Service Kits
L5255323153	Refer to Service Kits	L6156410253	L6156610253	L6456W80453	Refer to Service Kits
L5255323157	Refer to Service Kits	L6156510249	L6156610249	L6456Y10249	L6456Z10249
L5255323549	Refer to Service Kits	L6156610245	Refer to Service Kits	L6456Y10257	L6456Z10257
L5255721153	L5255821153	L6156610261	Refer to Service Kits	L6456110253	L6456310253
L5255821553	Refer to Service Kits	L6156610453	Refer to Service Kits	L6456110453	Refer to Service Kits
L5255822153	Refer to Service Kits	L6156610461	Refer to Service Kits	L6456210253	L6456310253
L5255822549	Refer to Service Kits	L6156810453	Refer to Service Kits	L6456280453	Refer to Service Kits
L5255822553	Refer to Service Kits	L6156910353	Refer to Service Kits	L6456280457	Refer to Service Kits
L5255823149	Refer to Service Kits	L6156910449L	Refer to Service Kits	L6456310261	Refer to Service Kits
L5255823153	Refer to Service Kits	L6256W21153	L6256Z21153	L6456310445	Refer to Service Kits
L5255823553	Refer to Service Kits	L6256121145L	Refer to Service Kits	L6456310453	Refer to Service Kits
L5255823553	Refer to Service Kits	L6256121153	L6256321153	L6456310457	Refer to Service Kits
L5255921353	Refer to Service Kits	L6256171153	Refer to Service Kits	L6456360249	Refer to Service Kits
L5255921553	Refer to Service Kits	L6256221153	L6256321153	L6456360253	Refer to Service Kits
L5255922149	Refer to Service Kits	L6256321553	Refer to Service Kits	L6456360257	Refer to Service Kits
L5255922153	Refer to Service Kits	L6256321557	Refer to Service Kits	L6456360453	Refer to Service Kits
L5255922553	Refer to Service Kits	L6256322149	Refer to Service Kits	L6456380245	Refer to Service Kits
L5255923153	Refer to Service Kits	L6256322153	Refer to Service Kits	L6456380253	Refer to Service Kits
L5255923553	Refer to Service Kits	L6256371153	Refer to Service Kits	L6456380253L	Refer to Service Kits
L54451102	Refer to Service Kits	L6256371553	Refer to Service Kits	L6456380445	Refer to Service Kits
L5455Z10453	Refer to Service Kits	L6256372153	Refer to Service Kits	L6456380453	Refer to Service Kits
L5455110249	L5455310249	L6256391153	Refer to Service Kits	L6456510253	L6456610253
L5455110253	L5455310253	L6256392149	Refer to Service Kits	L6456610245	Refer to Service Kits
L5455110453	Refer to Service Kits	L6256392153	Refer to Service Kits	L6456610251	Refer to Service Kits
L5455210245	Refer to Service Kits	L6256393153	Refer to Service Kits	L6456610259	Refer to Service Kits
L5455210249	L5455310249	L6256621140	Refer to Service Kits	L6456610261	Refer to Service Kits
L5455210253	L5455310253	L6256621145	Refer to Service Kits	L6456610449	Refer to Service Kits
L5455210257	L5455310257	L6256621161	Refer to Service Kits	L6456610449	Refer to Service Kits
L5455310242	Refer to Service Kits	L6256621561	Refer to Service Kits	L6456610453	Refer to Service Kits
L5455310245	Refer to Service Kits	L6256622153	Refer to Service Kits	L6456610453	Refer to Service Kits
L5455310251	Refer to Service Kits	L6256622157	Refer to Service Kits	L6456610461	Refer to Service Kits
L5455310259	Refer to Service Kits	L6256622353	Refer to Service Kits	L6456710253	L6456810253
L5455310353	Refer to Service Kits	L6256921353	Refer to Service Kits	L6456810453	Refer to Service Kits
L5455310451	Refer to Service Kits	L6256921549	Refer to Service Kits	L6456810453	Refer to Service Kits
L5455310453	Refer to Service Kits	L6256921553	Refer to Service Kits	L6456910353	Refer to Service Kits
L5455310457	Refer to Service Kits	L6256922153	Refer to Service Kits	L6456910353	Refer to Service Kits
L5455310459	Refer to Service Kits	L6256922549	Refer to Service Kits	L6456910453	Refer to Service Kits
L5455710253	L5455810253	L6256922553	Refer to Service Kits	L6456910453	Refer to Service Kits
L5455810449	Refer to Service Kits	L6256923153	Refer to Service Kits		

Standard Product Crossover Information

Valvair II – 1"

Valvair II 1"	Suggested Replacement	Valvair II 1"	Suggested Replacement	Valvair II 1"	Suggested Replacement
L6558110257	L6558310257	L6857380453	L6858380453	L6957621149	L6958621149
L6558210249	L6558310249	L6857410249	L6858610249	L6957621153	L6958621153
L6558210253	L6558310253	L6857510253	L6858610253	L6957621157	L6958621153
L6558210257	L6558310257	L6857610253	L6858610253	L6957622153	L6958622153
L6558210259	Refer to Service Kits	L6857610261	Refer to Service Kits	L6957623153	Refer to Service Kits
L6558210459	Refer to Service Kits	L6857610353	L6858610353	L6957921149	L6958921149
L6558310242	Refer to Service Kits	L6857610457	L6858610457	L6957921153	L6958921153
L6558310243	Refer to Service Kits	L6857810253	L6858810253	L6957921553	L6958921553
L6558310251	Refer to Service Kits	L6857810453	L6858810453	L6957922153	L6958922153
L6558310259	Refer to Service Kits	L6857910249	L6858910249	L6957923153	Refer to Service Kits
L6558310451	Refer to Service Kits	L6857910253	L6858910253	L6958121153	L6958321153
L6558710253	L6558710253	L6857910353	L6858910353	L6958272153	L6958372153
L6658121153	L6658321153	L6858180353	L6858280353	L6958422157	L6958622157
L6658122157	L6658322157	L6858180361	Refer to Service Kits	L6958521153	L6958621153
L6658221149	L6658321149	L6858210253	L6858310253	L6958722153	L6958822153
L6658221153	L6658321153	L6858380461	Refer to Service Kits	L6958923153	Refer to Service Kits
L6658221157	L6658321157	L6858410257	L6858610257	L6959271153	L6958371153
L6658221159	Refer to Service Kits	L6858410353	L6858610353	L6959272153	L6958372153
L6658221549	L6658321549	L6858410361	Refer to Service Kits	L6959291153	L6958391153
L6658321551	Refer to Service Kits	L6858410453	L6858610453	L6959422157	L6958622157
L6658722153	L6658822153	L6858410461	Refer to Service Kits	L6959523153	Refer to Service Kits
L6658923153	Refer to Service Kits	L6858510249	L6858610249	L6959623157	Refer to Service Kits
L6758W10249	L6758Z10249	L6859210253	L6858310253	L6959923153	Refer to Service Kits
L6758110249	L6758310249	L6859310253	L6858310253	L704711102	L704811102
L6758110253	L6758310253	L6859310257	L6858310257	L704911102	L704811102
L6758210249	L6758310249	L6859310261	Refer to Service Kits	L7057Z10253	L7058Z10253
L6758210253	L6758310253	L6859360253	L6858390653	L7057210253	L7058310253
L6758210257	L6758310257	L6859410257	L6858610257	L7057260453	L7058360453
L6758210259	Refer to Service Kits	L6859610245	L6858610245	L7057280453	L7058380453
L6758210453	L6758310453	L6859610249	L6858610249	L7057310245	L7058310245
L6758310241	Refer to Service Kits	L6859610253	L6858610253	L7057310249	L7058310249
L6758310242	Refer to Service Kits	L6859610261	Refer to Service Kits	L7057310253	L7058310253
L6758310259	Refer to Service Kits	L6859810253	L6858810253	L7057310257	L7058310257
L6758310440	Refer to Service Kits	L6859910249	L6858910249	L7057310261	Refer to Service Kits
L6758310451	Refer to Service Kits	L6859910253	L6858910253	L7057310453	L7058310453
L6758710253	L6758810253	L69471211	L69481211	L7057360249	L7058360249
L684711102	L684811102	L69471221	L69481221	L7057360253	L7058360253
L684911102	L684811102	L69471231	Refer to Service Kits	L7057360449	L7058360449
L6857210253	L6858310253	L69491211	L69481211	L7057360453	L7058360453
L6857210257	L6858310257	L6957121145L	L6958321145	L7057380249	Refer to Service Kits
L6857210253	L6858310253	L6957221153	L6958321153	L7057380253	L7058380253
L6857210257	L6858310257	L6957221553	L6958321553	L7057410253	L7058610253
L6857280453	L6858380453	L6957291553	L6958391553	L7057510253	L7058610253
L6857280457	Refer to Service Kits	L6957321149	L6958321149	L7057610245	L7058610245
L6857310240	Refer to Service Kits	L6957321153	L6958321153	L7057610249	L7058610249
L6857310253	L6858310253	L6957321157	L6958321157	L7057610253	L7058610253
L6857310349	L6858310349	L6957322149	L6958322149	L7057610257	L7058610257
L6857310359	Refer to Service Kits	L6957322153	L6958322153	L7057610449	L7058610449
L6857360253	L6858360253	L6957371153	L6958371153	L7057610457	L7058610457
L6857380249	Refer to Service Kits	L6957391153	L6958391153	L7057810253	L7058810253
L6857380253	L6858380253	L6957391549	L6958391549	L7057910249	L7058910249
L6857380257	Refer to Service Kits	L6957392153	L6958392153	L7057910253	L7058910253

Standard Product Crossover Information

Valvair II – 1"

<u>Valvair II 1"</u>	<u>Suggested Replacement</u>	<u>Valvair II 1"</u>	<u>Suggested Replacement</u>	<u>Valvair II 1"</u>	<u>Suggested Replacement</u>
L7057910353	L7058910353				
L7057910453	L7058910453				
L7058W80453	L7058Z80453				
L7058Y10253	L7058Z10253				
L7058Y10445	L7058Z10445				
L7058210253	L7058310253				
L7058260453	L7058360453				
L7058280253	L7058380253				
L7058280453	L7058380453				
L7058380253L	L7058380253				
L7058380453L	L7058380453				
L7058610243	Refer to Service Kits				
L7058610461	Refer to Service Kits				
L7059Z10253	L7058Z10253				
L7059110253	L7058310253				
L7059210253	L7058310253				
L7059210257	L7058310257				
L7059280453	L7058380453				
L7059310249	L7058310249				
L7059310253	L7058310253				
L7059310257	L7058310257				
L7059360249	L7058360249				
L7059360253	L7058360253				
L7059380253	L7058380253				
L7059410253	L7058610253				
L7059610249	L7058610249				
L7059610253	L7058610253				
L7059610257	L7058610257				
L7059610261	Refer to Service Kits				
L7059810253	L7058810253				
L7059810453	L7058810453				
L7059910249	L7058910249				
L7059910253	L7058910253				
L7059910453	L7058910453				

Specials History & Crossover Information SK-200 – 1/4"

SK200 1/4" Specials	Description	Repair Kit	Closest Replacement
L38053001	Single Solenoid, less base, with fluorocarbon seals	N/A	L38539104 + voltage
L38054001	Single Solenoid, less base, less pilot valve	K352088	L3854 X 102 + voltage
L41052001	Plug-In Speed King Valve with lubrication for dry service	K352151	L41529102 + voltage
L41052002	Plug-In Speed King Valve with indicator light for 230 / 50Hz	K352151	L4152310257
L41052003	Plug-In Speed King Valve with Lockwire and "VH" O-rings	K352151	L41529102 + voltage
L41052004	Plug-In Valve one remote cap and one remote time delay and less electrical plug	K352151	L41421102 + Time Delay
L41052005	Less subbase with remote caps and less electrical plug	K352357	L41421102
L41052006	Plug-In Valve with Lockwire on end caps and Lockwired to subbase	K352151	L41529102 + voltage
L41052007	Plug-In Valve less O-rings	K352151	L41529102 + voltage
L41052008	Less subbase Plug-In Speed King with Lockwire and special pilot	K352151	L4152910253
L41052009	Plug-In Valve with poly	N/A	N/A
L41052010	Plug-In Valve less Buna N O-rings with polyurethane O-rings	N/A	L41529104 + voltage
L41052011	Double Solenoid with special sealing agent on electrical plug	K352151	L4152910253
L41052012	Double Solenoid with stainless steel spool	K352151	N/A
L41052013	Double Solenoid with fluorocarbon seals	N/A	N/A
L42052001	Double Solenoid with speed controllers	K352151	L42529231** + 003381101
L42052002	Double Solenoid with speed controllers	K352151	L42529211** + 003381101
L42052003	Double Solenoid, for dry service lubrication	K352151	L42529211 + voltage
L42052004	Double Solenoid, with special O-rings	N/A	L42529211 + voltage
L42052005	Double Solenoid, with urethane O-rings	N/A	N/A
L42052006	Double Solenoid, with Normally Open and Normally Closed pilots	K352151	L42529211 + voltage
L42052007	Double Solenoid, ABP, with stainless steel spool	K352151	N/A
L42052008	Double Solenoid, CE, with stainless steel spool	K352151	N/A
L42052009	Double Solenoid, PC, with stainless steel spool	K352151	N/A
L44052001	Single Solenoid, for non-lube service	K352150	L44529102 + voltage
L44052002	Single Solenoid, lubricated with Lubri-Plate	N/A	N/A
L44052003	Single Solenoid, for non-lube service	K352150	L44529102 + voltage
L44052004	Single Solenoid, with lighted 230 / 50Hz lighted coil	K352150	L4452310257
L44052005	Single Solenoid, with high temperature seals	N/A	N/A
L44052006	Single Solenoid, with remote operators	K352363	L44421102
L44052007	Single Solenoid, with high temperature seals	N/A	N/A
L44052008	Single Solenoid, with special end caps and pilot valve	K352150	N/A
L44052009	Single Solenoid, with VH O-rings	N/A	N/A
L44052010	Single Solenoid, with sealing agent on electrical plug	K352150	L44523102 + voltage
L44052011	Single Solenoid, with special piston for external pilot thru pilot inlet	K352150	N/A
L44052012	Single Solenoid, with polyurethane O-rings	N/A	N/A
L44052013	Single Solenoid, with polyurethane O-rings and 200 PSI pilot	N/A	N/A
L44052014	Single Solenoid, with solid state controls	K352150	N/A
L44052015	Single Solenoid, with sealing agent on electrical plug	K352150	L44529102 + voltage
L44052016	Single Solenoid, with stainless steel spool	K352150	N/A
L44052017	Single Solenoid, lubricated with Lubri-Plate	N/A	N/A
L44052018	Single Solenoid, with fluorocarbon seals and high temperature coil	N/A	N/A
L44052019	Single Solenoid, with fluorocarbon seals and high temperature coil	N/A	N/A
L46042001	Double Remote Pilot, with time delay	K352357	L46421102 + time delay module
L46042002	Double Remote Pilot, with internal pilot supply	K352357	N/A
L46042003	Double Remote Pilot, with cylinder operators	K352357	N/A
L46042004	Double Remote Pilot, with time delay	K352357	L46421102 + time delay module
L46042005	Double Remote Pilot, with fluorocarbon O-rings	N/A	N/A
L46043001	Double Remote Pilot, with adapters for air bleed assemblies	K352357	N/A
L46052001	Double Solenoid, with special coil	K352151	N/A
L46052002	Double Solenoid, with special coil	K352151	N/A
L46052003	Double Solenoid, with external pilot supply	K352151	L4652410**

Specials History & Crossover Information SK-200 – 1/4"

SK200 1/4"

Specials	Description	Repair Kit	Closest Replacement
L46052004	Double Solenoid, with special lubricant	N/A	N/A
L46052005	Double Solenoid, with high temperature - Nema 4 coil, 125VDC	K352151	N/A
L46052006	Double Solenoid, with special pilot	K352151	N/A
L46052007	Double Solenoid, less pilot valve	K352151	L4652 * 102 **
L46052008	Double Solenoid, with BSPT threads	K352151	N/A
L46053001	Double Solenoid, with high temperature coil	K352151	N/A
L46053002	Double Solenoid, with special pilot orientation	K352151	L46533602**
L46053003	Double Solenoid, with suppressors	K352151	N/A
L46053004	Double Solenoid, with 250VDC coils	K352151	N/A
L46053005	Double Solenoid, with special 125VDC coil	K352151	N/A
L47042001	Double Remote Pilot, with special remote adapters	K352357	N/A
L47043001	Double Remote Pilot, with special stem	K352357	N/A
L47052001	Double Solenoid, with 1 - NO pilot and 1 - NC pilot	K352151	N/A
L47052002	Double Solenoid, with 1 - NO pilot and 1 - NC pilot	K352151	N/A
L47052003	Double Solenoid, with 1 - NO pilot and 1 - NC pilot	K352151	N/A
L47053001	Double Solenoid, with 1 - NO pilot and 1 - NC pilot	K352151	N/A
L47053002	Double Solenoid, with 1 - NO pilot and 1 - NC pilot	K352151	N/A
L47053003	Double Solenoid, with special stem	K352151	N/A
L47053004	Double Solenoid, with speed controls	K352151	L47533211 + voltage and flow controls
L48042001	Single Remote Pilot, inline valve, with special remote cap	K352363	N/A
L48042003	Single Remote Pilot, inline valve, with fluorocarbon O-rings	N/A	N/A
L48043001	Single Remote Pilot, inline valve, with special pilot cap	K352363	L48431102
L48052001	Single Solenoid, inline valve, with high temperature seals	N/A	N/A
L48052002	Single Solenoid, inline valve, with special lubrication	N/A	N/A
L48052003	Single Solenoid, inline valve, with high temperature seals	N/A	N/A
L48052004	Single Solenoid, inline valve, with Class "H" coil, 115V / 60Hz, continuous duty	K352150	N/A
L48052005	Single Solenoid, inline valve, with Class "H" coil, 125VDC, hazardous location	K352150	N/A
L48052006	Single Solenoid, inline valve, less coil	K352150	L48529102 **
L48052007	Single Solenoid, inline valve, with special pilot, less coil	K352150	N/A
L48052008	Single Solenoid, inline valve, with special NC pilot valve	K352150	N/A
L48052009	Single Solenoid, inline valve, with polyurethane O-rings	K352150	N/A
L48052010	Single Solenoid, inline valve, with special lubrication	N/A	N/A
L48052011	Single Solenoid, inline valve, with 6 foot leads on coils	K352150	L48523102 + voltage
L48052012	Single Solenoid, inline valve, with suppressors	K352150	L48529102 + voltage
L48052013	Single Solenoid, inline valve, with special override and 36 inch leads	K352150	L48529102 + voltage
L48052014	Single Solenoid, inline valve, with 36 inch leads	K352150	L4852310253
L48052015	Single Solenoid, inline valve, less coil	K352150	L48523604 + voltage
L48053001	Single Solenoid, inline valve, with Class "H" coil, Nema 4, 115V / 60Hz	K352150	N/A
L48053002	Single Solenoid, inline valve, with Class "H" coil, hazardous and continuous duty	K352150	N/A
L48053003	Single Solenoid, inline valve, with special non-locking override	K352150	L48536102 + voltage
L48053004	Single Solenoid, inline valve, with Class "H" coil, Nema 4	K352150	N/A
L48053005	Single Solenoid, inline valve, with Class "H" coil, Nema 4 125VDC	K352150	N/A
L48053006	Single Solenoid, inline valve, with fluorocarbon seals	N/A	N/A
L48053007	Single Solenoid, inline valve, with special non-locking override	K352150	L4853610253
L48053008	Single Solenoid, inline valve, with special 125VDC coil	K352150	N/A
L48053009	Single Solenoid, inline valve, with 55V / 60Hz rating	K352150	N/A

Specials History & Crossover Information SK-200 – 3/8"**SK200 3/8"**

Specials	Description	Repair Kit	Closest Replacement
L6504C001	Double Remote Pilot, with subbase, with fluorocarbon	N/A	N/A
L65053001	Double Solenoid, less base, with drilled pilot exhaust	K352126	L65533102 + voltage
L65053002	Double Solenoid, less base, with drilled pilot exhaust	K352126	L6553910253
L65053003	Double Solenoid, less base, with drilled pilot exhaust	K352126	L6553810253
L65053004	Double Solenoid, less base, with drilled pilot exhaust	K352126	L65532102 + voltage
L65053005	Double Solenoid, less base, with drilled pilot exhaust	K352126	L6553210261
L65053006	Double Solenoid, less base, with fluorocarbon O-rings	N/A	N/A
L65053007	Double Solenoid, less base, with blank pilot spacer	K352126	N/A
L65053008	Double Solenoid, less base, with one NC and one NO solenoid	K352126	N/A
L65053009	Double Solenoid, less base, with stainless steel stem	K352126	N/A
L65053010	Double Solenoid, less base, with stainless steel stem	K352126	N/A
L65053011	Double Solenoid, less base, with class "H" coil and 10 foot leads	K352126	N/A
L65053012	Double Solenoid, less base, with special spool	K352126	N/A
L65053013	Double Solenoid, less base, with drilled pilot exhaust	K352126	N/A
L65053014	Double Solenoid, less base, with blocked inlet port	K352126	N/A
L65053015	Double Solenoid, less base, with blocked inlet port	K352126	N/A
L65053016	Double Solenoid, less base, with blocked exhaust ports	K352126	N/A
L65053017	Double Solenoid, less base, with gasket plate	K352126	L65539102 + voltage
L65053018	Double Solenoid, less base, with stainless steel stem	K352126	N/A
L65053019	Double Solenoid, less base, with special spring return override	K352126	L6553910253
L65053020	Double Solenoid, less base, with low-temperature lube and stainless steel spool	N/A	N/A
L65053021	Double Solenoid, less base, with blocked inlet port	K352126	N/A
L66043001	Double Remote Pilot, with special drilling	K352355	N/A
L66043002	Double Remote Pilot, with special drilling	K352355	N/A
L66043003	Double Remote Pilot, with locking overrides	K352355	L66431221
L66053001	Double Solenoid, less base, with one NO and one NC solenoid	K352126	N/A
L66053003	Double Solenoid, less base, with plugged override on "B" solenoid	K352126	L66532231
L66053004	Double Solenoid, less base, with blank exhaust spacers	K352126	N/A
L66053005	Double Solenoid, less base, with one continuous duty solenoid and special pistons	K352126	N/A
L66053006	Double Solenoid, less base, with blank exhaust spacers	K352126	N/A
L66053007	Double Solenoid, less base, with 75VDC coil	K352126	N/A
L66053008	Double Solenoid, less base, with 125VDC coil	K352126	L6653221161
L66053009	Double Solenoid, with base, with grounding screw in base	K352126	L66539211 + voltage
L66053011	Double Solenoid, less base, with one NO and one NC solenoid	K352126	N/A
L66053012	Double Solenoid, less base, with 32VDC coil	K352126	N/A
L66053014	Double Solenoid, less base, with remote adapters	K352126	N/A
L66053015	Double Solenoid, less base, with blank inlet spacer	K352126	N/A
L66053016	Double Solenoid, less base, with one NO and one NC solenoid	K352126	N/A
L66053018	Double Solenoid, less base, with special override	K352126	L6653923153
L66053019	Double Solenoid, less base, with conduit type operators	K352126	N/A
L66053020	Double Solenoid, less base, with blank inlet spacer	K352126	N/A
L66053021	Double Solenoid, less base, with blank inlet spacer	K352126	N/A
L66053022	Double Solenoid, less base, with blank inlet spacer	K352126	N/A
L66053024	Double Solenoid, less base, with 37VDC coil	K352126	N/A
L67043001	Single Remote Pilot, Valve only, with timing sequence delay	K352362	L67431102 + K7051003
L67043002	Single Remote Pilot, Valve only, with timing sequence delay	K352362	L67431102 + K7051002
L67053001	Single Solenoid, Valve only, with fluorocarbon O-rings, 115VAC / 60Hz	N/A	N/A
L67053002	Single Solenoid, Valve only, with spring return	K352124	L67539102 + voltage
L67053005	Single Solenoid, Valve only, with NC pilot using adapters	K352124	N/A
L67053007	Single Solenoid, Valve only, with blank end spacers	K352124	N/A
L67053008	Single Solenoid, Valve only, with blank end spacers	K352124	N/A
L67053009	Single Solenoid, Valve only, with blank end spacers, 120VAC	K352124	N/A

Specials History & Crossover Information SK-200 – 3/8"

SK200 3/8" Specials	Description	Repair Kit	Closest Replacement
L67053010	Single Solenoid, Valve only, with stainless steel spool	K352124	N/A
L67053011	Single Solenoid, Valve only, with 3-pin Brad Harrison connector	K352124	L67539102 + voltage
L67053012	Single Solenoid, Valve only, with 3-pin Brad Harrison connector	K352124	L67539102 + voltage
L67053013	Single Solenoid, Valve only, with high temperature seal and coil less shockpad	N/A	N/A
L67053014	Single Solenoid, Valve only, with fluorocarbon O-rings	N/A	N/A
L67053015	Single Solenoid, Valve only, with internal exhaust drilling	K352124	N/A
L67053016	Single Solenoid, Valve only, with blank spacer at inlet	K352124	N/A
L67053017	Single Solenoid, Valve only, with gasket plate	K352124	L6753910453
L67053018	Single Solenoid, Valve only, with 75VDC coil	K352124	N/A
L67053019	Single Solenoid, Valve only, with 125VDC coil	K352124	L6753210261
L67053020	Single Solenoid, Valve only, with 32VDC coil	K352124	N/A
L67053021	Single Solenoid, Valve only, with special spring return override	K352124	L6753910253
L67053023	Single Solenoid, valve only, with fluorocarbon O-rings	N/A	N/A
L67053024	Single Solenoid, valve only, with JIC pilot valve	K352124	N/A
L67053025	Single Solenoid, valve only, with high temperature seal and coil, external pilot	N/A	N/A
L67053027	Single Solenoid, valve only, with blank spacer at inlet, 24VDC	K352124	N/A
L67053028	Single Solenoid, valve only, with blank end spacers, 24VDC	K352124	N/A
L67053029	Single Solenoid, valve with base, with high temperature seal and coil, 24VDC	N/A	N/A
L67053030	Single Solenoid, valve with base, with high temperature seal and coil, 120VAC	N/A	N/A
L68044001	Double Remote Pilot, inline valve, with special air bleed remote adapters	K352355	N/A
L68054001	Double Solenoid, inline valve, with high temperature seals and coil, NEMA 4, 120VAC	N/A	N/A
L68054002	Double Solenoid, inline valve, with stainless steel spool, 120VAC	K352126	N/A
L68054003	Double Solenoid, inline valve, with stainless steel spool, 24VDC	K352126	N/A
L68054004	Double Solenoid, inline valve, with stainless steel spool, 120VAC	K352126	N/A
L68054005	Double Solenoid, inline valve, with high temperature seals	N/A	N/A
L68054006	Double Solenoid, inline valve, with high temperature seals and coil, NEMA 4, 120VAC	N/A	N/A
L69043001	Double Remote Pilot, inline valve, with special drilling in body	K352355	N/A
L69044001	Double Remote Pilot, inline valve, with special drilling in body	K352355	N/A
L69053001	Double Solenoid, inline valve, with stainless steel spool	K352126	N/A
L69054001	Double Solenoid, inline valve, with class "H" coil, 120VAC	K352126	N/A
L69054002	Double Solenoid, inline valve, with hazardous duty solenoid	K352126	L69543721 + voltage
L69054003	Double Solenoid, inline valve, with two NC solenoids and adapter	K352126	N/A
L69054004	Double Solenoid, inline valve, with speed controls	K352126	L6954321553 + flow controls
L70044001	Single Remote Pilot, inline valve, with fluorocarbon O-rings	N/A	N/A
L70044002	Single Remote Pilot, inline valve, with offset spring	K352362	L70441102
L70053001	Single Solenoid, inline valve, with stainless steel spool	K352124	N/A
L70053003	Single Solenoid, inline valve, with suppressors	K352124	L70539102 + voltage
L70053004	Single Solenoid, inline valve, with 32VDC coil, and special service gasket	K352124	N/A
L70053005	Single Solenoid, inline valve, with 250VDC coil	K352124	N/A
L70053006	Single Solenoid, inline valve, with special grease and hydraulic gasket	N/A	N/A
L70054001	Single Solenoid, inline valve, with 48VDC coil, class "H" coil, fluorocarbon O-rings	N/A	N/A
L70054002	Single Solenoid, inline valve, with 48VDC coil, class "H" coil, fluorocarbon O-rings	N/A	N/A
L70054003	Single Solenoid, inline valve, with class "H" coil, fluorocarbon O-rings	N/A	N/A
L70054004	Single Solenoid, inline valve, with suppressors	K352124	L70549102 + voltage
L70054005	Single Solenoid, inline valve, with stainless steel spool	K352124	N/A
L70054006	Single Solenoid, inline valve, with class "H" coil, and special name tag	K352124	N/A
L70054007	Single Solenoid, inline valve, with 48 inch leads	K352124	L7054610257
L70054008	Single Solenoid, inline valve, with fluorocarbon O-rings and 48VDC coil	N/A	N/A
L70054009	Single Solenoid, inline valve, with fluorocarbon O-rings	N/A	N/A
L70054010	Single Solenoid, inline valve, Nema 4 solenoid with 24VDC class "B" coil	N/A	N/A

Specials History & Crossover Information SK-200 – 1/2"**SK200 1/2"**

Specials	Description	Repair Kit	Closest Replacement
L51045001	Double Remote Pilot, less base, with sequence timer	K352358	L51451102 + timer
L51045002	Double Remote Pilot, less base, with air bleed	K352358	N/A
L51055001	Double Solenoid, less base, with special lubrication	N/A	N/A
L51055002	Double Solenoid, less base, with blocked exhaust ports	K352153	N/A
L51055003	Double Solenoid, less base, with aluminum spool	K352153	N/A
L51055004	Double Solenoid, less base, with light 240VAC	K352153	L5155310257
L51055005	Double Solenoid, less base, with remote pilot adapter	K352153	N/A
L51055006	Double Solenoid, less base, with one remote pilot adapter	K352153	N/A
L51055007	Double Solenoid, less base, with drilled internal pilot supply	K352153	N/A
L51055009	Double Solenoid, less base, with conduit connection and Brad Harrison connector	K352153	N/A
L51055010	Double Solenoid, less base, with stainless steel spool	K352153	N/A
L51055011	Double Solenoid, less base, less pilot	K352153	L51451102
L51055012	Double Solenoid, less base, with special override	K352153	L5155910253
L51055013	Double Solenoid, less base, with special plate to raise pilot	K352153	N/A
L52055001	Double Solenoid, less base, lubricated for non-lube service	N/A	N/A
L52055002	Double Solenoid, less base, with remote adapter	K352153	N/A
L52055004	Double Solenoid, less base, with lead sealing agent	K352153	L52553221 + voltage
L52055005	Double Solenoid, less base, with 230VDC coil	K352153	N/A
L52055006	Double Solenoid, less base, with blank exhaust spacers	K352153	N/A
L52055007	Double Solenoid, less base, with conduit connection and Brad Harrison connector	K352153	N/A
L52055008	Double Solenoid, less base, with conduit connection and Brad Harrison connector	K352153	N/A
L52055009	Double Solenoid, less base, with blank exhaust spacers	K352153	N/A
L52055010	Double Solenoid, less base, with stainless steel spool	K352153	N/A
L52055011	Double Solenoid, less base, with stainless steel spool	K352153	N/A
L52055012	Double Solenoid, less base, with stainless steel spool	K352153	N/A
L52055013	Double Solenoid, with base, with 5-pin connector in base	K352153	L5255921153
L52055014	Double Solenoid, less base, with blank exhaust spacers	K352153	N/A
L54055001	Single Solenoid, less base, lubricated with special grease	N/A	N/A
L54055002	Single Solenoid, less base, with special coated spool	K352152	N/A
L54055004	Single Solenoid, less base, with light for 240VAC	K352152	L5455310257
L54055005	Single Solenoid, less base, with remote pilot adapter	K352152	N/A
L54055006	Single Solenoid, less base, with shock pads	K352152	L54558102 + voltage
L54055007	Single Solenoid, less base, with lead sealing agent	K352152	L54553102 + voltage
L54055008	Single Solenoid, less base, with non-plug in pilot valve	K352152	N/A
L54055009	Single Solenoid, less base, with NEMA 4 pilot	K352152	N/A
L54055010	Single Solenoid, less base, with internal / external pilot supply convertibility	K352152	L54554102 + voltage
L54055011	Single Solenoid, less base, with conduit connection and Brad Harrison connector	K352152	N/A
L54055014	Single Solenoid, less base, with conduit connection	K352152	N/A
L54055015	Single Solenoid, less base, with stainless steel spool	K352152	N/A
L54055016	Single Solenoid, less base, less pilot	K352152	N/A
L54055017	Single Solenoid, less base, with raised electrical connection	K352152	N/A
L61055001	Double Solenoid, inline, with drilled internal pilot exhaust	K352153	N/A
L61055002	Double Solenoid, inline, with 50VAC / 50Hz coil	K352153	N/A
L61056001	Double Solenoid, inline, with class "H" coil, 120VAC / 60Hz	K352153	N/A
L62045001	Double Remote Pilot, inline, with special service gaskets	K352358	N/A
L62046001	Double Remote Pilot, inline, with special service gaskets	K352358	N/A
L62046002	Double Remote Pilot, inline, with special service gaskets	K352358	N/A
L62056001	Double Solenoid, inline, with 75VDC coil	K352153	N/A

Specials History & Crossover Information SK-200 – 1/2"

SK200 1/2"

Specials	Description	Repair Kit	Closest Replacement
L62056002	Double Solenoid, inline, with 48VAC / 50Hz coil	K352153	N/A
L62056003	Double Solenoid, inline, with 75VDC coil	K352153	N/A
L62056004	Double Solenoid, inline, with 37VDC coil	K352153	N/A
L64046001	Single Remote Pilot, inline, with fluorocarbon seals	N/A	N/A
L64055001	Single Solenoid, inline, with special override	K352151	L6455510253
L64056001	Single Solenoid, inline, with "VH" O-rings	N/A	N/A
L64056002	Single Solenoid, inline, with special service pilot and class "H" coil	K352151	N/A
L64056003	Single Solenoid, inline, with class "H" coil, 115VAC / 60Hz	K352151	N/A
L64056004	Single Solenoid, inline, with class "H" coil, 115VAC / 60Hz	K352151	N/A

Rohr Valvair

Specials History & Crossover Information Valvair II – 1"**Valvair II 1"**

Specials	Description	Repair Kit	Closest Replacement
L65058001	Double Solenoid, less base, with NC pilot	K352130	N/A
L65058002	Double Solenoid, less base, with NC pilot and light	K352130	N/A
L65058003	Double Solenoid, less base, with NC pilot	K352130	N/A
L65058004	Double Solenoid, less base, with NC pilot	K352130	N/A
L65058005	Double Solenoid, less base, with conduit operator connection	K352130	N/A
L65058006	Double Solenoid, with base, with Brad Harrison connection in base	K352130	L6558810253
L65058007	Double Solenoid, less base, with Brad Harrison connection in pilot	K352130	N/A
L65058008	Double Solenoid, less base, less pilot	K352130	L6558910253
L66058001	Double Solenoid, less base, with blank spacers at exhaust	K352130	N/A
L66058002	Double Solenoid, less base, with one continuous duty solenoid	K352130	N/A
L66058003	Double Solenoid, less base, with 75VDC coil	K352130	N/A
L66058004	Double Solenoid, less base, with one remote pilot operator	K352130	N/A
L66058005	Double Solenoid, less base, with special pilot	K352130	N/A
L67058001	Single Solenoid, less base, with 120VAC class "H" coil and 10 foot leads	K352128	N/A
L67058002	Single Solenoid, less base, with 4-pin connector in pilot	K352128	N/A
L67058003	Single Solenoid, less base, with NEMA 4 JIC pilot	K352128	N/A
L67058004	Single Solenoid, less base, less pilot	K352128	L6758910253
L69057001	Double Solenoid, inline, with spotfaces on ports	K352130	N/A
L70057001	Single Solenoid, inline, with suppressors	K352128	N/A
L70058001	Single Solenoid, inline, with class "H" coil, 48VDC	K352128	N/A

Parker Specials Crossover Information**A4, A5 Series Specials**

A4 or A5 Specials	Description	Repair Kit	Closest Replacement
A4C1A43Y001	Single Solenoid, inline valve, with fluorocarbon seals and class H coil	K35020050 + K352366	L7054380453 - with Buna N seal
A4C1A43Y002	Single Solenoid, inline valve, with fluorocarbon seals and external pilot	K35020050 + K352366	L7054380453 - with Buna N seal
A431A43Y001	Single Solenoid, with special non-locking override	K352124	L7054510253
A431531Y001	Single Solenoid, with base, with 60VAC / 60Hz coil and BSPP ports	K352124	N/A
A431533Y001	Single Solenoid, with base, with 3-pin connector in base	K352124	L6753910253 + K022090
A431543Y001	Single Solenoid, with base, with fluorocarbon seals and external pilot	K35020050 + K352166	L6753910253 + K022091
A431543Y002	Single Solenoid, with base, with special non-locking override	K352124	L6753810253 + K022091
A431553Y001	Single Solenoid, with base, with fluorocarbon seals and external pilot	K35020050 + K352166	L6753910253 + K022101
A431553Y002	Single Solenoid, with base, with fluorocarbon seals and external pilot	K35020050 + K352166	L6753910249 + K022101
A441VXXY001	Double Solenoid, less base, with anodized body	K352126	L6553210257
A441533Y001	Double Solenoid, with base, with 3-pin connector in base	K352126	L6553910253 + K022090
A471553Y001	Single Remote Pilot, with base, with special pilot adapter	K352362	L67431102 + K022101
A531A53Y001	Single Solenoid, inline valve, with 200 PSI pilot	K352152	L6453210353
A531553Y001	Single Solenoid, with base, with 200 PSI pilot	K352152	L5455210353 + K022093